

OCTOBER 18TH 2025

HALL B HIGHLIGHTS – JLUO DNP SATELLITE MEETING

NOÉMIE PILLEUX
Postdoctoral appointee, ANL



2025 – ALERT EXPERIMENT

- Fundamental structure of light nuclei and bound nucleons
- ^4He and D targets:
 - EMC effect
 - Bound neutrons
 - ...
- Recoil tagging in exclusive and inclusive reactions

A Low Energy Recoil Tracker

- Stereo drift chamber for reconstruction at momenta down to 70 MeV for protons
- Time-of-flight array of scintillators for particle identification p, D, ^3H , ^3He , ^4He .

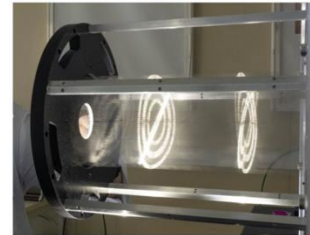
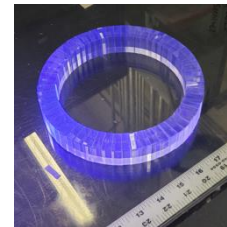
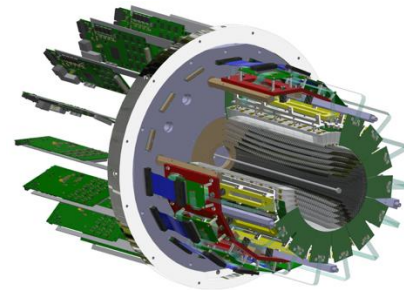
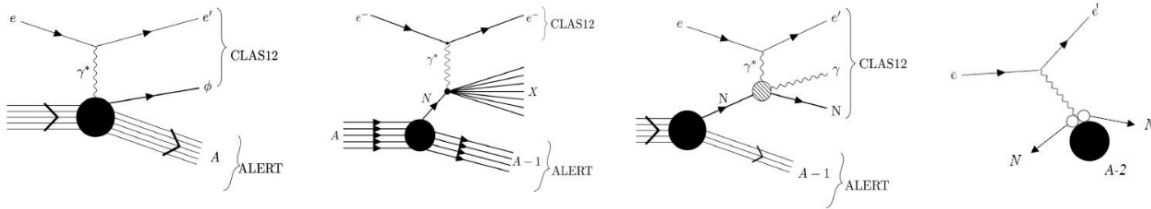

E12-17-012	Partonic structure of light nuclei
E12-17-012A	Tagged EMC measurements on light nuclei
E12-17-012B	Spectator-tagged DVCS on light nuclei

E12-17-012C	Other physics opportunities with ALERT
E12-23-013	Measuring short-range correlations with ALERT

2025 DATA TAKING

Scheduled Experiments	Setup / Status	Target	Beam Energy	Start Date	End Date	Scheduled Calendar Days	Remaining PAC Days Before Run	Scheduled PAC Days = Cal.Days/2	Actual PAC Days from ABUs
RG-L	ALERT	gas	2.1	2025-04-05	2025-04-12	7	55.0	3.5	1.0
	pass change			2025-04-12					
RG-L	ALERT	gas	11	2025-04-12	2025-08-01	111	54.0	55.5	52.0
	pass change			2025-08-01					
RG-L	ALERT	gas	2.1	2025-08-01	2025-08-04	3	2.0	1.5	2.0
	pass change			2025-08-04					
RG-L	ALERT	gas	6.6	2025-08-04	2025-09-03	30	17.0	15.0	15.0
SAM 2025	reconfigure	change		2025-09-03	2026-02-01	151	sums:	75.5	70.0

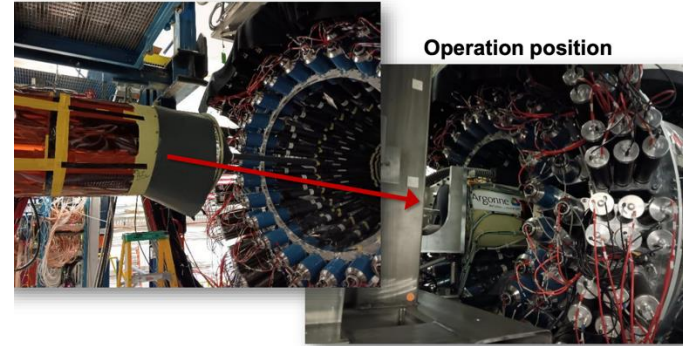

- Overall smooth running with the ALERT detector with only minor issues, all solved quickly
- Highest running electron beam current ever in Hall B!
 - CLAS12 subsystem performances assessed for currents up to 500nA on the gas ^4He target
 - 325 nA found to be a stable running point
- 1/3 data on D, 2/3 data on ^4He
- >90% of the approved statistics

ALERT PERFORMANCES

Now focusing on detector calibrations and ALERT software

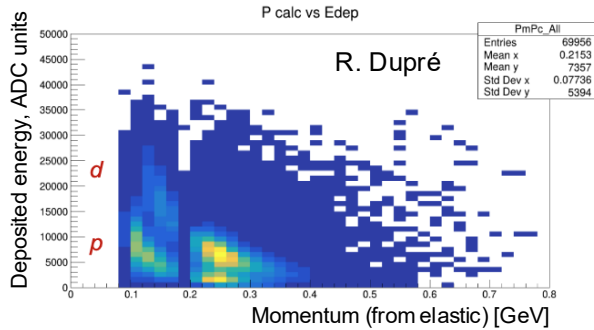

PID promises with uncalibrated detectors!

2.2 GeV elastic events

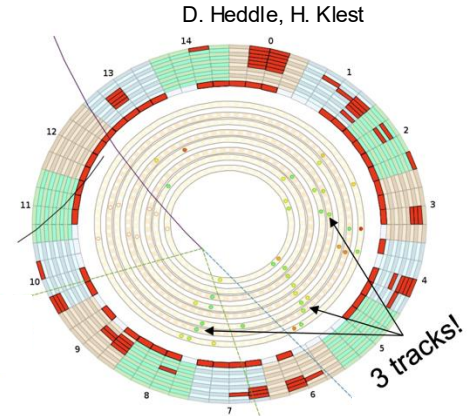
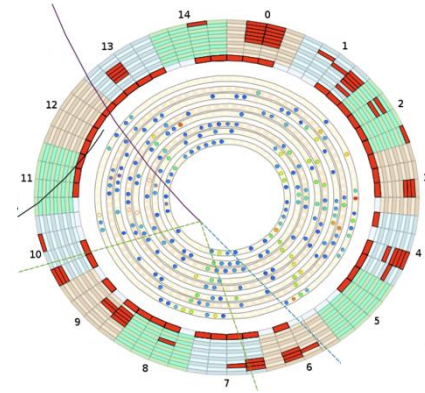
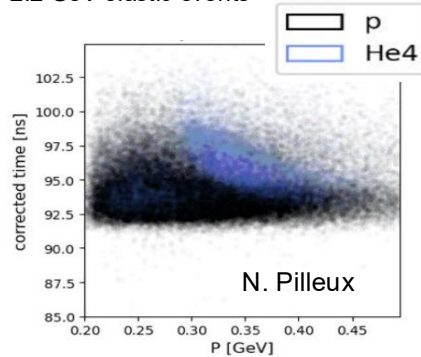

ALERT talks:

M.Ouillon 11:06 am – 11:18 am, Monday October 20 // Session T10

N.Pilleux 11:54 am – 12:06 pm, Monday October 20 // Session T09

2026 DATA TAKING

Scheduled Experiments	Setup / Status	Target	Beam Energy	Start Date	End Date	Scheduled Calendar Days	Remaining PAC Days Before Run	Scheduled PAC Days = Cal.Days/2	Actual PAC Days from ABUs	Remaining PAC Days After Run
PRad-II/X17	HyCal/GEMs	Radiator	3.5	2026-02-20	2026-02-27	7	40.0	3.5		36.5
PRad-II	HyCal/GEMs	H2 gas	3.5	2026-02-27	2026-03-27	28	36.5	14.0		22.5
	pass change			2026-03-27						
PRad-II	HyCal/GEMs	H2 gas	0.7	2026-03-27	2026-04-17	21	22.5	10.5		12.0
	CEBAF rescale			2026-04-20	2026-05-02	12				
PRad-II	HyCal/GEMs	H2 gas	2.2	2026-05-02	2026-06-01	30	12.0	15.0		-3.0
	reconfigure	change		2026-06-01	2026-06-06					
X17	HyCal/GEMs	Ta foil	2.2	2026-06-06	2026-07-26	50	60.0	25.0		35.0
SAM 2026						sum:	148		sum:	68.0

E12-20-004	High precision measurement of proton charge radius (PRad-II)
E12-21-003	A direct detection search for hidden sector new particles (X17)

X17: Search for the X17, hypothetical explanation for anomaly in the ^8Be nuclear transition, possibly connected to dark matter.

Prad-II: Measurement of the proton charge radius.

PRAD-II AND X17 PHYSICS PROGRAM

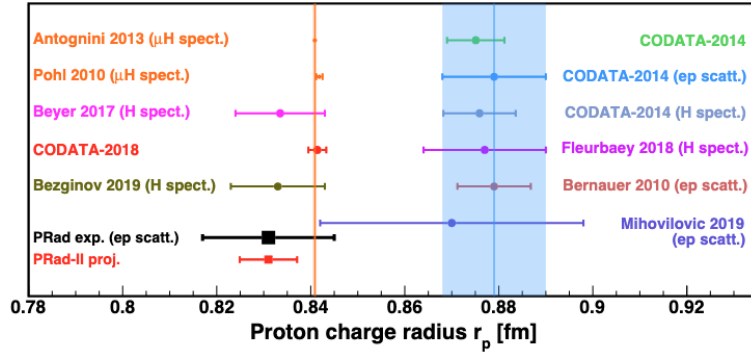

X17:

- Existence or upper limit on X17
- “hidden sector” in [3 – 60] MeV mass range in eN collision, with e+e- and $\gamma\gamma$ channels
- Bump hunting in invariant mass spectrum over standard model background

From PRad to PRad-II:

- Improved statistics (uncertainty/4)
- Improved systematics:
 - New Moller electron veto
 - Improved tracking
 - Beam blocker
 - Improved energy resolution
- To be able to extract proton radius with high precision and reach $Q^2 = 10^{-5} \text{ GeV}^2$

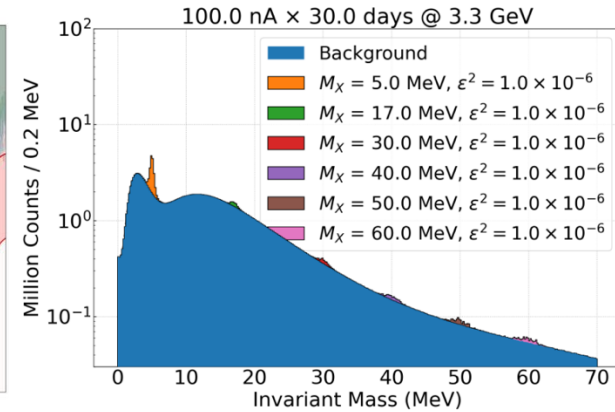
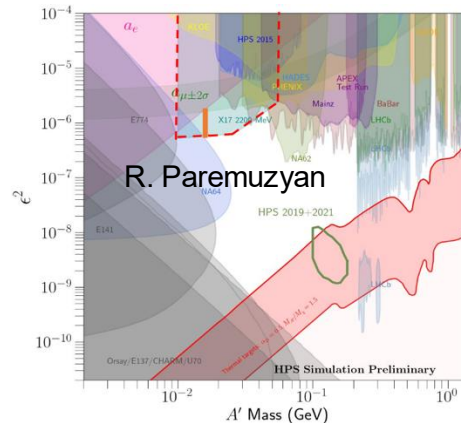

PRAD AND X17 SETUPS

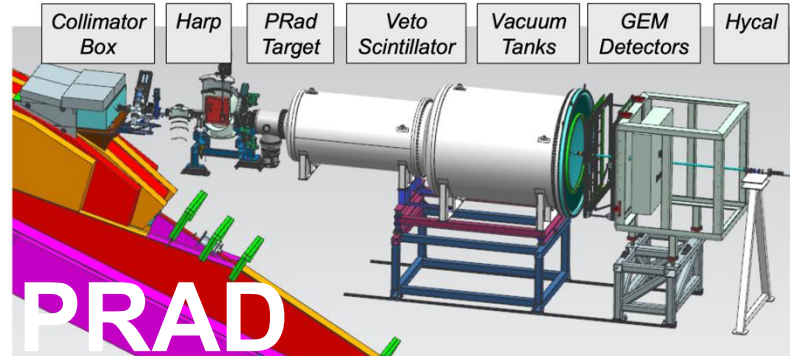
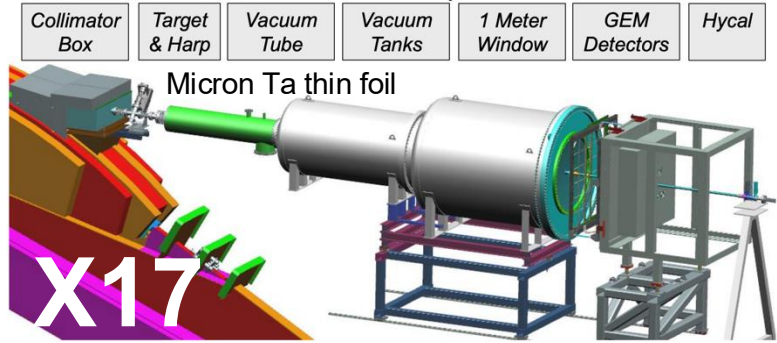

Hycal for electrons and gamma
 1156 PbWO4 modules with
 new fADC readout

GEMs for precision tracking

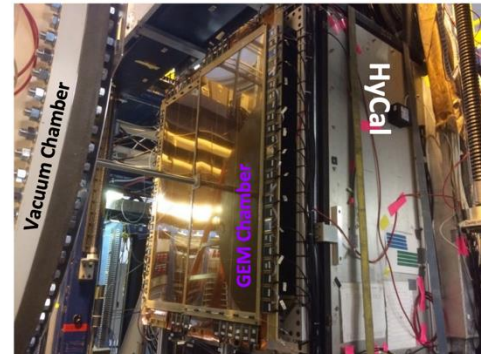
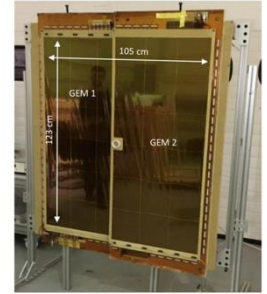

STATUS

All subsystem testing and setup are in the final stage

GEM detectors construction complete
Commissioning at JLab ongoing



H2 target performance
validated

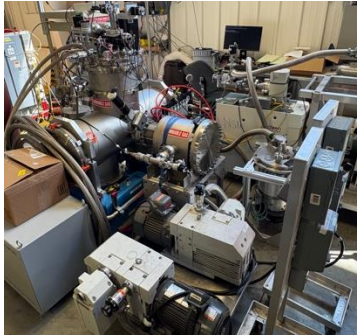

HyCal recommissioning with new fADC readout
Preparing to be installed



Veto Scintillator constructed,
calibration, ready for installation



Tagger recommissioning in progress

DAQ tests ongoing

And ongoing
analysis efforts!

E. Wrightson 8:30 am – 10:18 am, Saturday October 18 // Session D09
D. Higinbotham, T. Hague 9:30 am – 9:42 am, Saturday October 18 // Session D09
N. Kularatne 2:00 pm – 2:12 pm, Sunday October 19 // Session N10
B. Tamang 2:12 pm – 2:24 pm, Sunday October 19 // Session N10

HALL B THESES

THE STRUCTURE FUNCTION OF THE FREE NEUTRON AT

HIGH X -BJORKEN

by

Madhusadhan Pokhrel
B. Sc. December 2013, Tribhuvan University, Nepal
M. Sc. December 2016, Tribhuvan University, Nepal
M. S. May 2019, Old Dominion University, USA

A Dissertation Submitted to the Faculty of
Old Dominion University in Partial Fulfillment of the
Requirements for the Degree of

DOCTOR OF PHILOSOPHY

PHYSICS

OLD DOMINION UNIVERSITY
May 2025

Approved by:

Stephen Baumann (Director)
Sebastian Kuhn (Member)
Raul Briceo (Member)
Yuan Zhang (Member)
Sylvain Marsillac (Member)

M. Pokhrel

FIRST CLAS12 DOUBLE-PION ($N\pi\pi$) ELECTROPRODUCTION ANALYSIS

by

Krishna Chandra Neupane

Bachelor of Science
Tribhuvan University, 2011

Master's Degree in Physics
Tribhuvan University, 2014

Submitted in Partial Fulfillment of the Requirements

for the Degree of Doctor of Philosophy in

Physics

College of Arts and Sciences

University of South Carolina

2025

Accepted by:

Ralf Gothe, Major Professor
Fred Myhrer, Committee Member
Steffen Strauch, Committee Member
Viktor Mokeev, Committee Member
Ann Vail, Dean of the Graduate School

K. Neupane

Nucleon structure studies: DVCS on polarised protons with the CLAS12 experiment,
and development of Micromegas detectors for EIC

S. Polcher – Paris
Saclay University

Exploring the Nucleon Structure
via Deep Electroproduction Processes

J-S. Alvarado – Paris
Saclay University

CLAS AND CLAS12 PUBLICATIONS

12. M. McEaney *et al.* (*CLAS Collaboration*), "Longitudinal Spin Transfer to Λ Hyperons with CLAS12", arXiv:2509.05758, submitted to Phys. Rev. C (2025).
 11. H. Jiang *et al.* (*CLAS Collaboration*), "Polarization Observables T and F in the $\gamma p \rightarrow \pi^0 p$ Reaction at CLAS", arXiv:2508.17589, submitted to Phys. Rev. C (2025).
 10. S. Adhikari *et al.* (*CLAS Collaboration*), "Measurement of Beam-Recoil Observables C_x and C_z for $K^+\Lambda$ Photoproduction", arXiv:2508.10124, submitted to Phys. Rev. C (2025). ([summary](#))
 9. S.A. Dytman *et al.* (*CLAS Collaboration*), "Proton Transparency and Neutrino Physics: New Methods and Modeling", arXiv:2508.01905, submitted to Phys. Rev. C (2025).
 8. A. Kripko *et al.* (*CLAS Collaboration*), "Multidimensional Measurements of Beam Single Spin Asymmetries in Semi-Inclusive Deep-Inelastic Charged Kaon Electroproduction off Protons in the Valence Region", arXiv:2504.08580, submitted to Phys. Rev. Lett. (2025).
 7. D.S. Carman *et al.* (*CLAS Collaboration*), "Recoil Polarization in K^+Y Electroproduction in the Nucleon Resonance Region with CLAS12", Phys. Rev. C 112, 035206 (2025). ([paper](#)), ([summary](#))
 6. T. Mineeva *et al.* (*CLAS Collaboration*), "Suppression of Neutral Pion Production in Deep-Inelastic Scattering of Nuclei with the CLAS Detector", Phys. Rev. C 112, 035203 (2025). ([paper](#))
 5. P. Roy *et al.* (*CLAS Collaboration*), "Measurement of Single- and Double-Polarization Observables in the Photoproduction of $\pi^+\pi^-$ Pairs off the Proton Using CLAS at Jefferson Laboratory", Phys. Rev. C 112, 035201 (2025). ([paper](#))
 4. V. Klimenko *et al.* (*CLAS Collaboration*), "Inclusive Electron Scattering in the Resonance Region from a Hydrogen Target with CLAS12", Phys. Rev. C 112, 025201 (2025). ([paper](#)), ([slide](#)), ([summary](#))
 3. A.V. Sarantsev *et al.* (*CLAS Collaboration*), "Photoproduction of two Charged Pions off Protons in the Resonance Region", Phys. Rev. C 111, 035203 (2025). ([paper](#))
 2. A. Deur *et al.* (*CLAS Collaboration*), "Measurement of the Nucleon Spin Structure Functions for $0.01 < Q^2 < 1 \text{ GeV}^2$ Using CLAS", Phys. Rev. C 111, 035202 (2025). ([paper](#))
 1. L. Clark *et al.* (*CLAS Collaboration*), "Photoproduction of the Σ^+ Hyperon Using Linearly Polarized Photons with CLAS", Phys. Rev. C 111, 025204 (2025). ([paper](#))
- A.V. Sarantsev *et al.* *Decays of N^* and Δ^* Resonances into Np , $\Delta\pi$, and $N\pi(500)$* , Phys. Rev. C 112, 015202 (July 2025)
 - Gregory Matousek and Anselm Vossen, *AI-Assisted Object Condensation Clustering for Calorimeter Shower Reconstruction at CLAS12* Nucl.Instrum.Meth.A 1082 (2026)
 - Gagik Gavalian and Richard Tyson, *Online Electron Reconstruction at CLAS12*, submitted to Comput. Phys. Commun. (2025)

PAC 53 (JULY 2025)

Electro- and photo-production of muon pairs with μ CLAS12
P.Chatagnon, S.Stepanyan
245 PAC days, scientific rate A, C1.

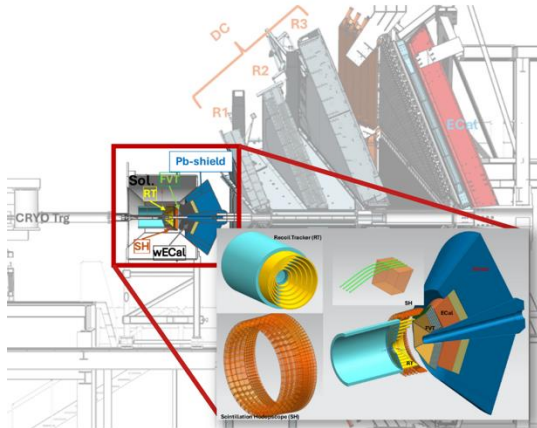

A Measurement of the Coherent J/psi Electro-production Cross-Section off ^4He
S.Lee, W.Armstrong.
100 PAC days, C2.

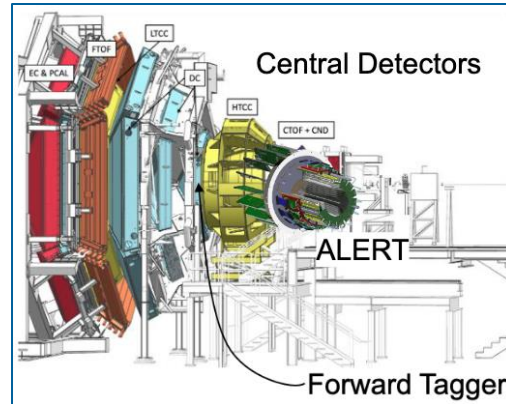

CLAS12 Run-group H Experiments with a Transverse Polarized Target
M. Contalbrigo.
125 days, Approved.

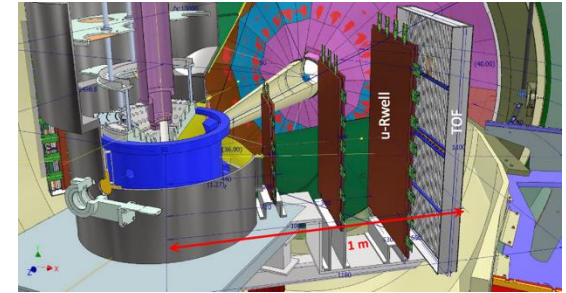

With run group addition
Measurements of Single Spin Asymmetries in exclusive production of hadrons with CLAS run group H transversely polarized target
H. Avakian.
Endorsed.