

A' Search Experiments with Positron Beam at Jefferson Lab

Bogdan Wojtsekhowski (JLab), Ashot Gasparian (NC A&T)

Weizhi Xiong (Shandong Univ.)

Low Energy Electron Positron Physics Workshop at Jefferson Lab

March. 23rd – 27th 2026



Outline

NASA FINDS DIRECT PROOF OF DARK MATTER

- Introduction
- A' search with JLab e^+ beam proposal (C12+24-005)
- Possibility to extend to lower beam energy
- Summary

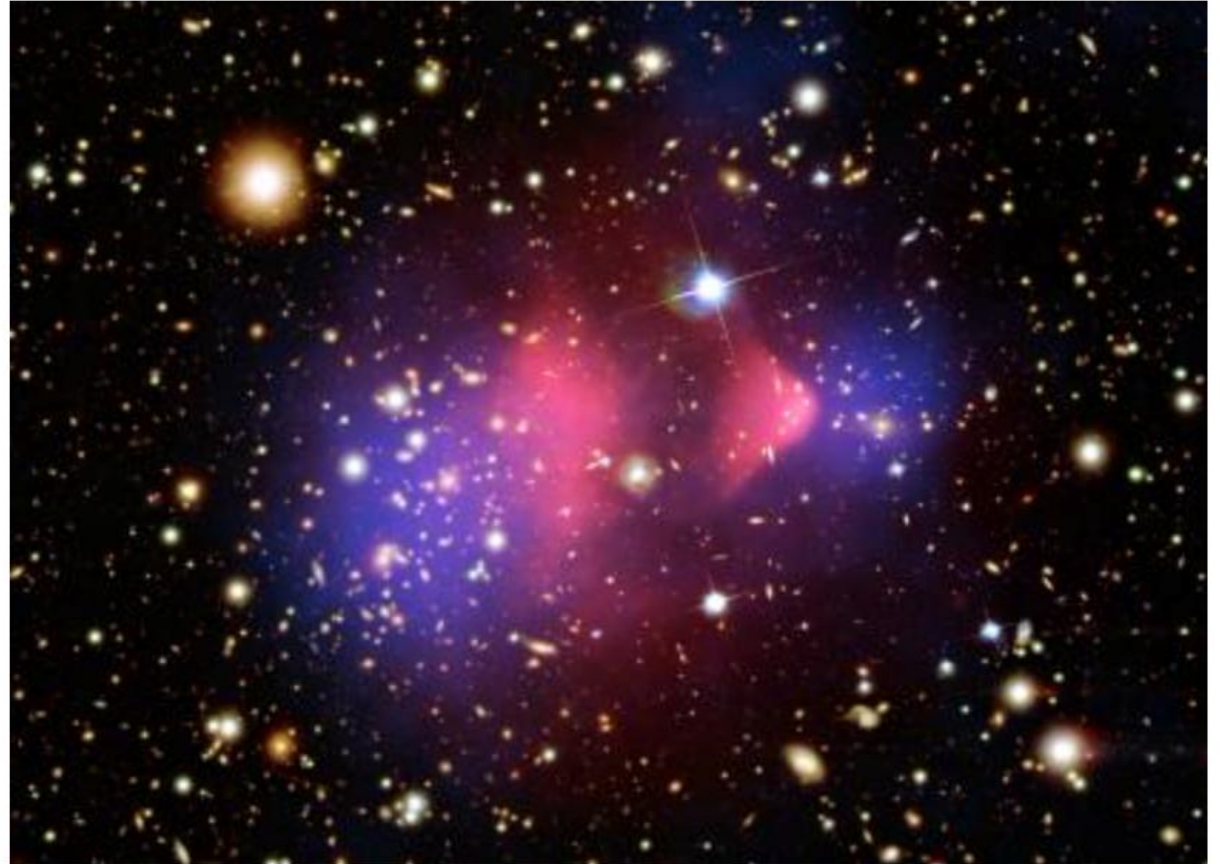

Credit: X-ray: NASA/CXC/CfA/M.Markevitch et al.; Optical: NASA/STScI; Magellan/U.Arizona/D.Clowe et al.;
Lensing Map: NASA/STScI; ESO WFI; Magellan/U.Arizona/D.Clowe et al.

Introduction

The processes which could have a U-boson

C.Boehm, P.Fayet, Nuclear Physics B 683 (2004)

A.4. Constraints from $g-2$

$g_e-2, g_\mu-2$
 π, η decays to $U\gamma$
 π, ϕ, ψ decays to $\gamma + \text{invisible}$

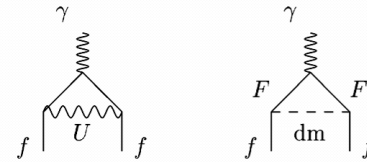

If the U boson mainly decays into dark matter, then the U production process turns out to be of the type $e^+e^- \rightarrow \gamma + \cancel{E}$, where \cancel{E} is missing energy, which is of interest in experiments searching for single photon production events. But, in the case of a light dark matter candidate, such a process is likely to remain unobserved, owing to the large background associated with $e^+e^- \rightarrow \gamma\gamma$, in which one of the two photons escapes detection.

Upper limit for the coupling constant $|f_{eU}|^2 < 2 \cdot 10^{-8} (m_U)^2$

A.6.1. Direct U boson production

$\epsilon^2 < 10^{-4}$ at 10 MeV

No specific restriction on
 U/A' decay mode!

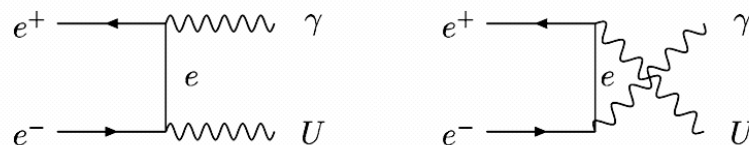

A Worldwide Effort of Dark Photon Search

- Different Search Techniques:
 - Bump hunting, beam dump, displaced vertex, rare decays...
- Search by different decay channels:
 - Search in visible decay ($A' \rightarrow e^+e^-$): APEX, HPS, X17 search, DarkLight...
 - Search in beam dump: BDX, SLAC...
 - Search by invisible and semi-invisible decay: NA64...
 - ...

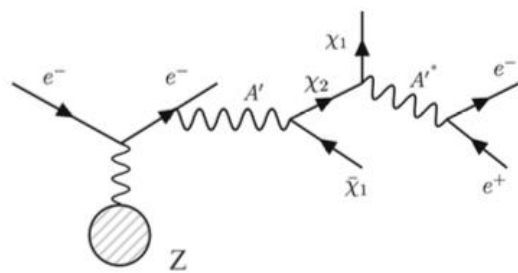

Fig. 1 Production of A' and subsequent semi-visible decay chain of a Dark Photon, $e^-Z \rightarrow e^-ZA'$; $A' \rightarrow \chi_1\chi_2(\chi_2 \rightarrow \chi_1e^+e^-)$

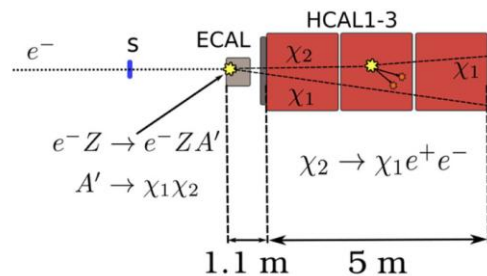
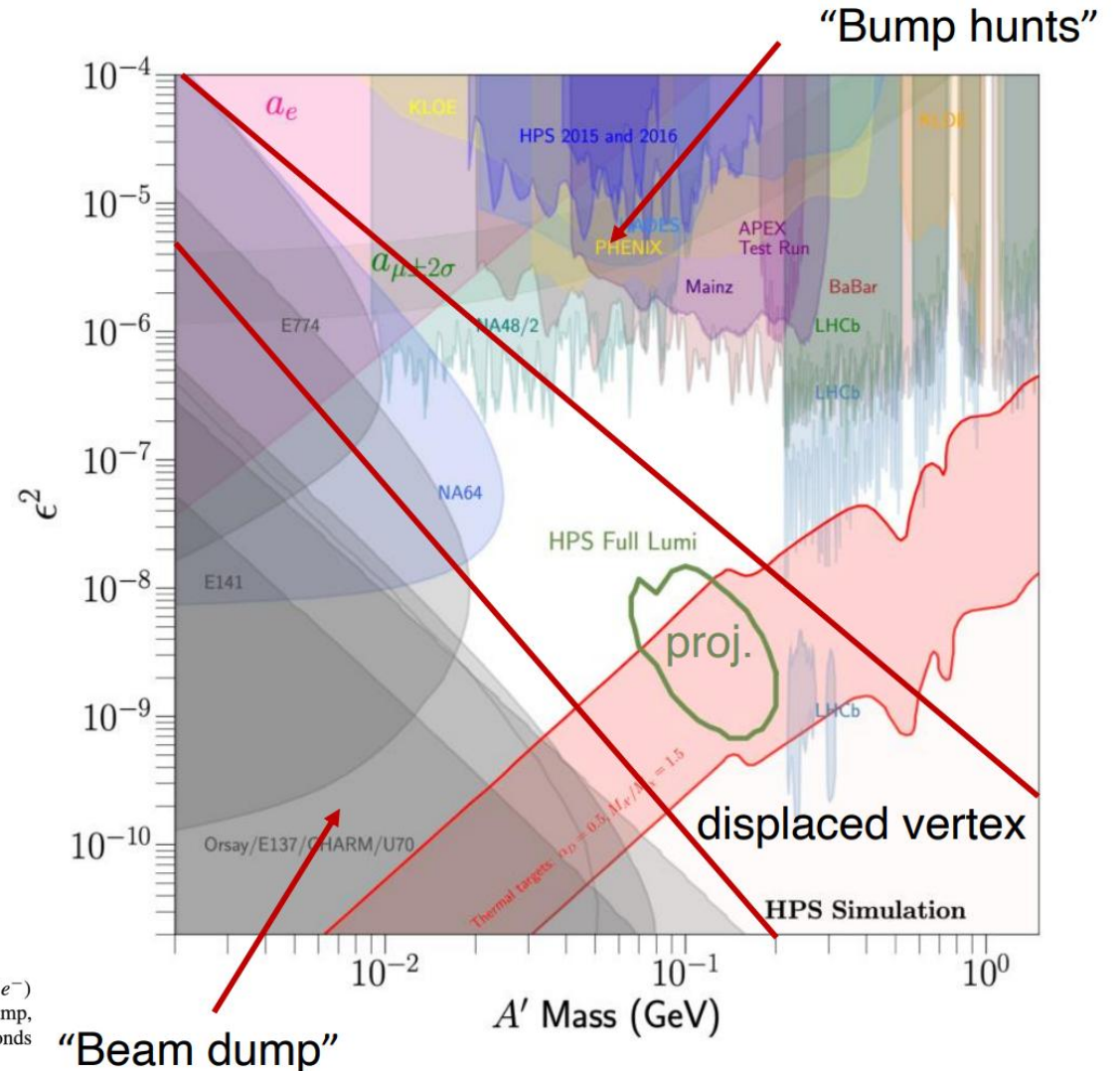

Fig. 3 A schematic view of an event $A' \rightarrow \chi_1\chi_2(\chi_2 \rightarrow \chi_1e^+e^-)$ from a A' produced after a 100 GeV e^- scatters off in the active dump, $e^-Z \rightarrow e^-ZA'$. The χ_2 particle decaying within HCAL2 corresponds to the S1 signature (see text for more details)



Dark Photon Search with Single- γ from e^+e^- Annihilation

- Using e^+e^- annihilation with **positron beam** and **atomic electrons** in LH2
- Selecting one-photon final state events and search for bump in M_x spectrum
- **Independent of A' decay mode**
- Require detection of forward-going photons with high resolution

$$M_{A'}^2 = 2m_e^2 + 2m_e * (E_+ - E_\gamma) - 4E_+ * E_\gamma * \sin^2\left(\frac{\theta_\gamma}{2}\right)$$

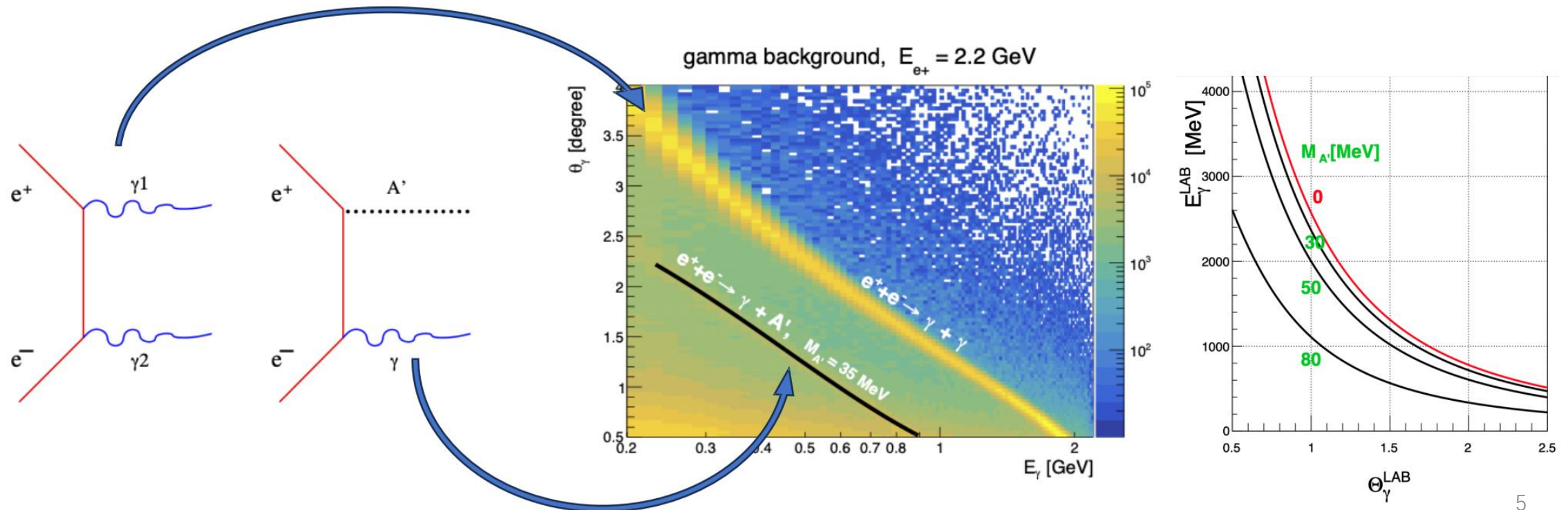

Dark Photon Search with e^+ Beam at JLab

- Proposal (C12+24-005) approved by PAC 52 for **55 days with A- rating**
 - C1: depending on e^+ beam availability
- 50 nA e^+ beam at 2.2/4.4/11 GeV on 5 cm long LH2
- Experimental setup largely based on existing PRIMEX/PRad/PRad-II apparatus
- With an additional **sweeper dipole magnet** and a **local beam dump**
- fADC - based DAQ with programmable trigger, 20 MHz

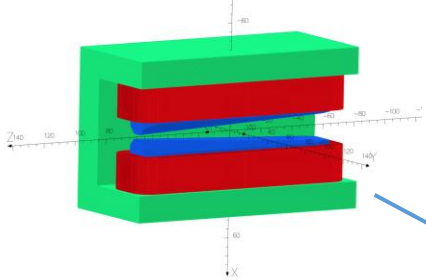

sweeper dipole magnet:
~1.2m long, with
2.8° aperture
dipole magnet

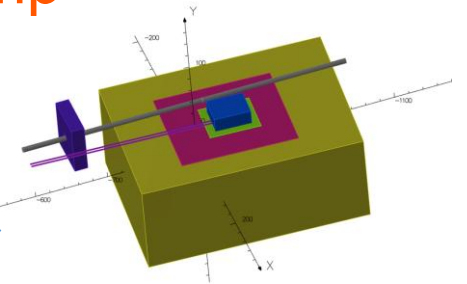
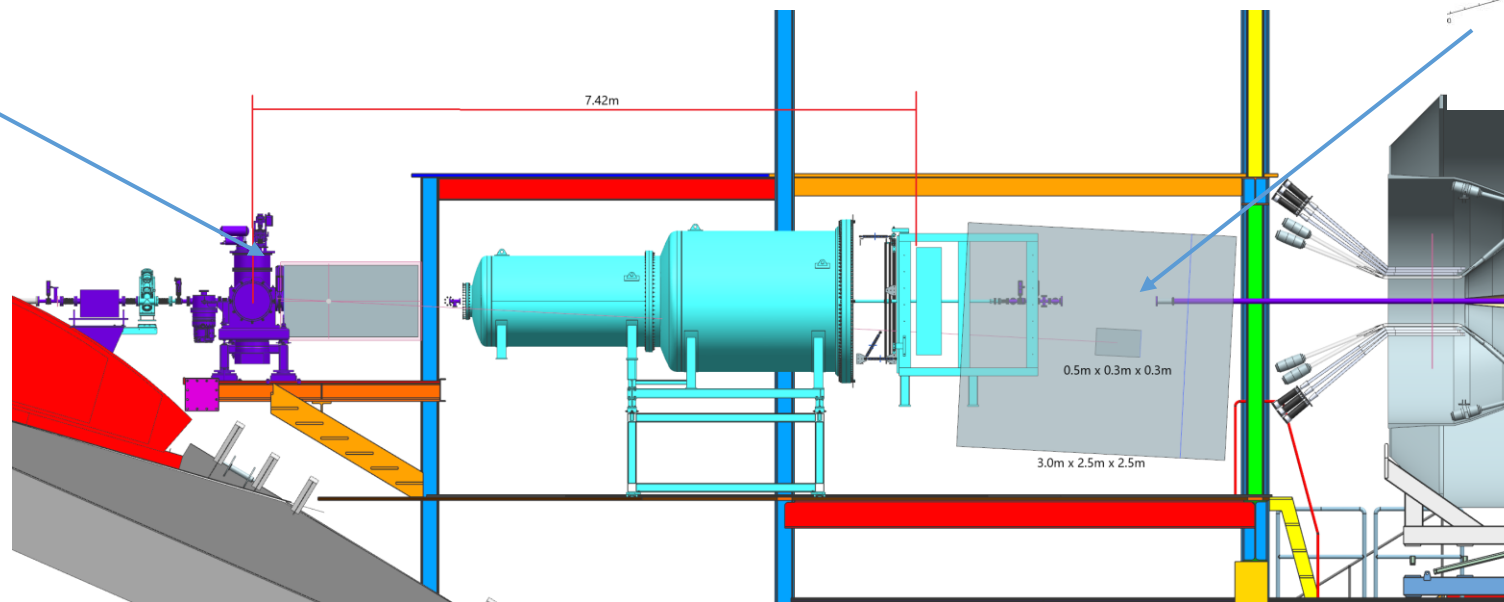

local beam dump:
Multiple layer
(W/Concrete/Poly)

Experimental Apparatus

High resolution PbWO4 calorimeter (HyCal)

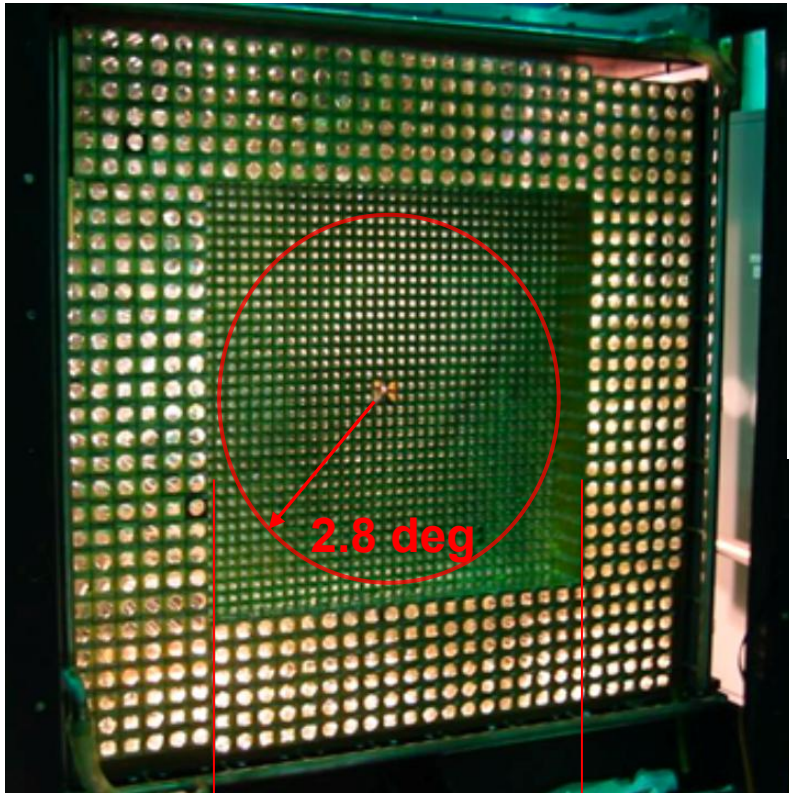

68 cm x 68 cm
+/- 2.8 degrees

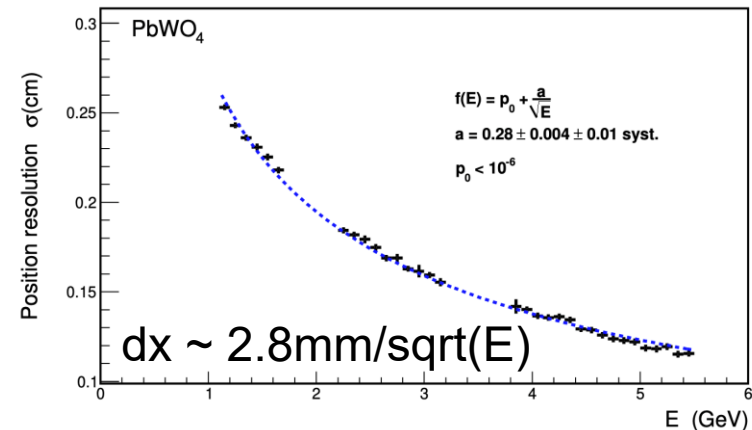
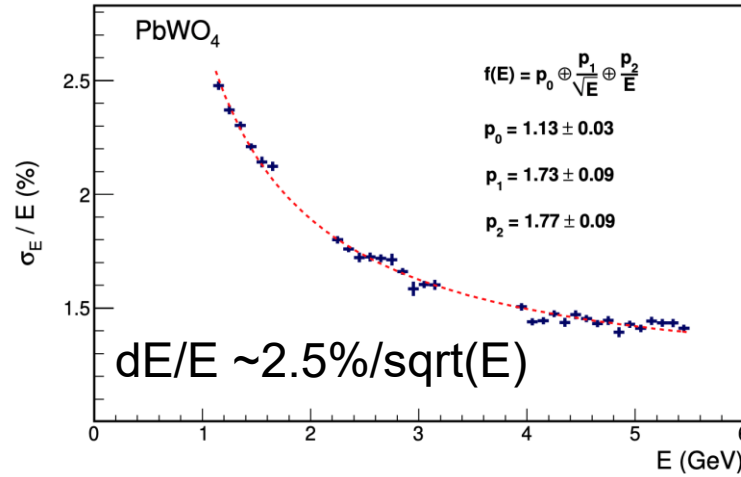

Gas Electron Multiplier (GEM), used for photon position calibration

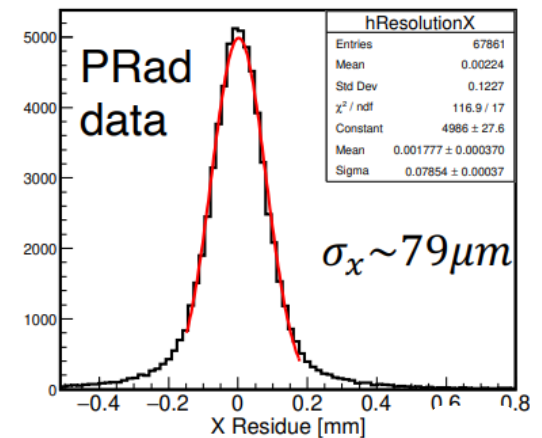

Radiation Damage and Resolution

- At extreme forward angle, background rate and radiation very high, exceeds **1000 Rad/hr** without sweeper magnet
- Ideally < 30 Rad/hr for PbWO4 to maintain good resolution
- A sweeper magnet of 2 T*m field integral to reduce radiation to **~10 Rad/hr**
- More data on radiation effect on resolution will be available this year with the upcoming Hall B X17 search experiment (summer 2026)

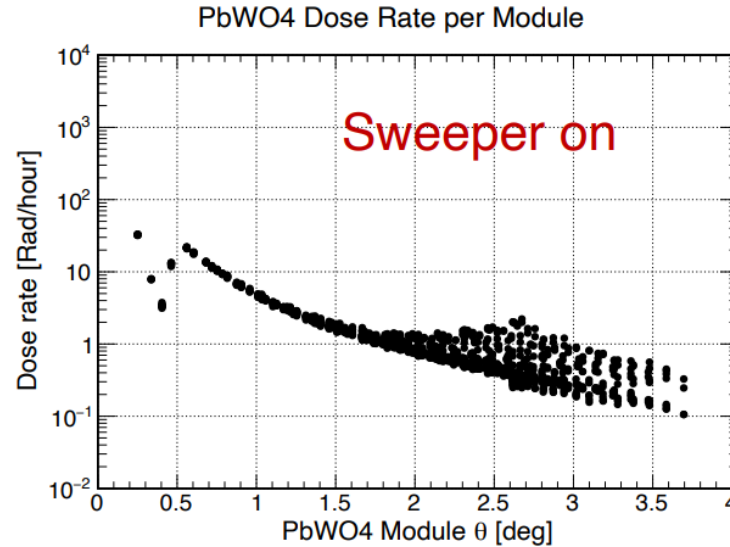
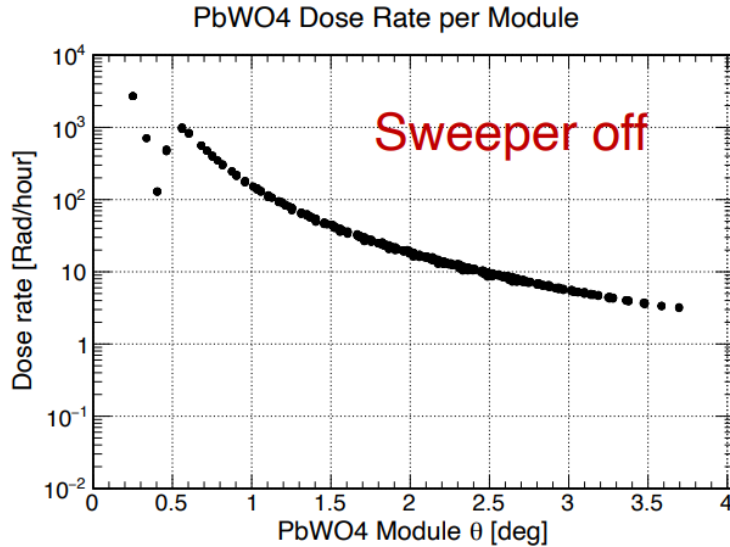

Conservatively estimated based on simulation

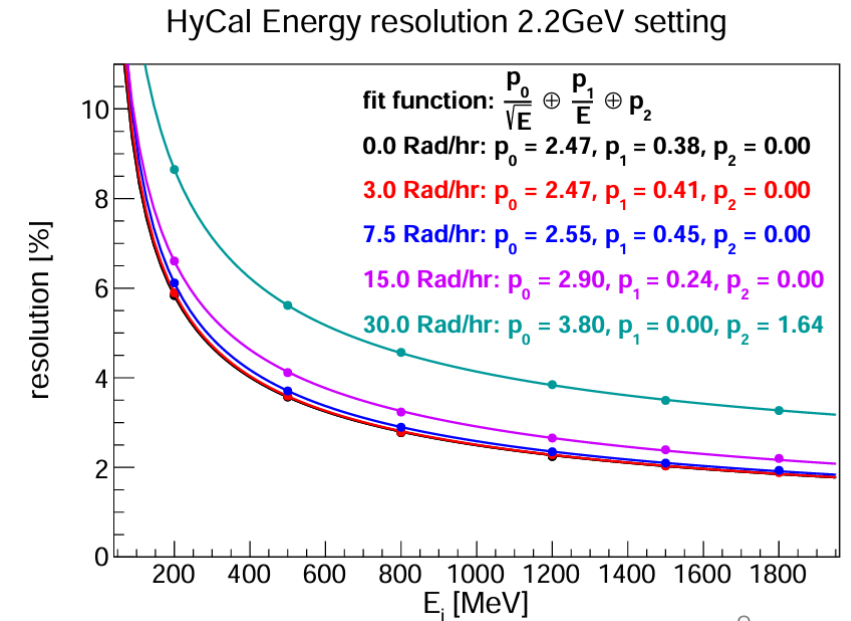

Local Beam Dump and Neutron Shielding

Geant4 model of the A' search experiment

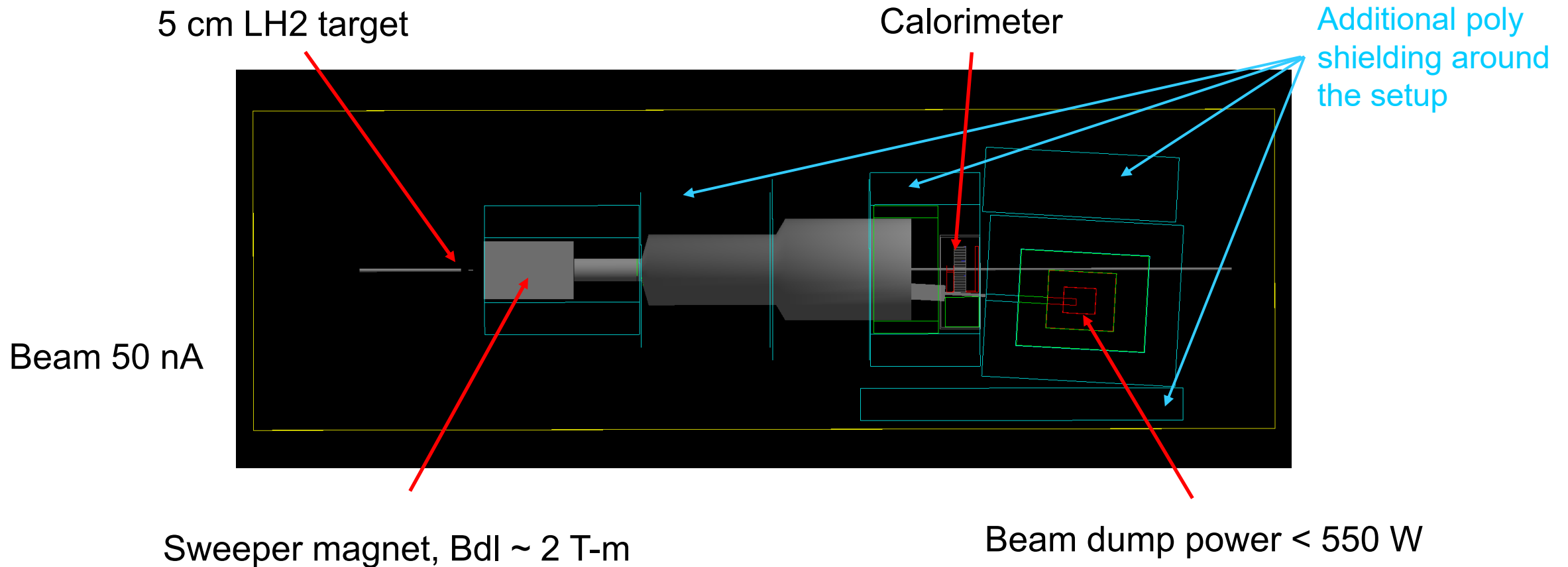

Local Beam Dump and Neutron Shielding

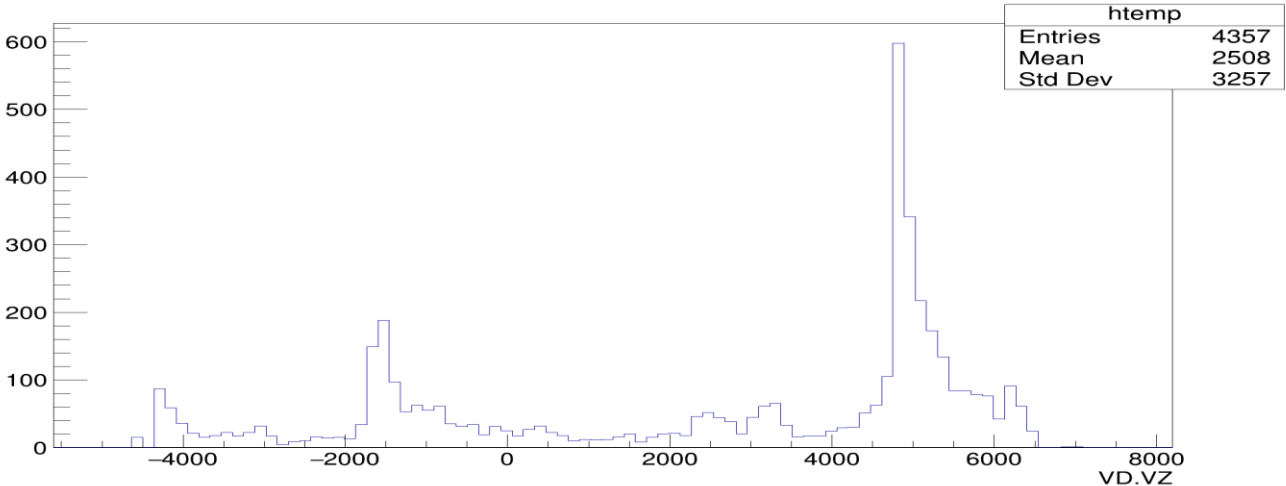
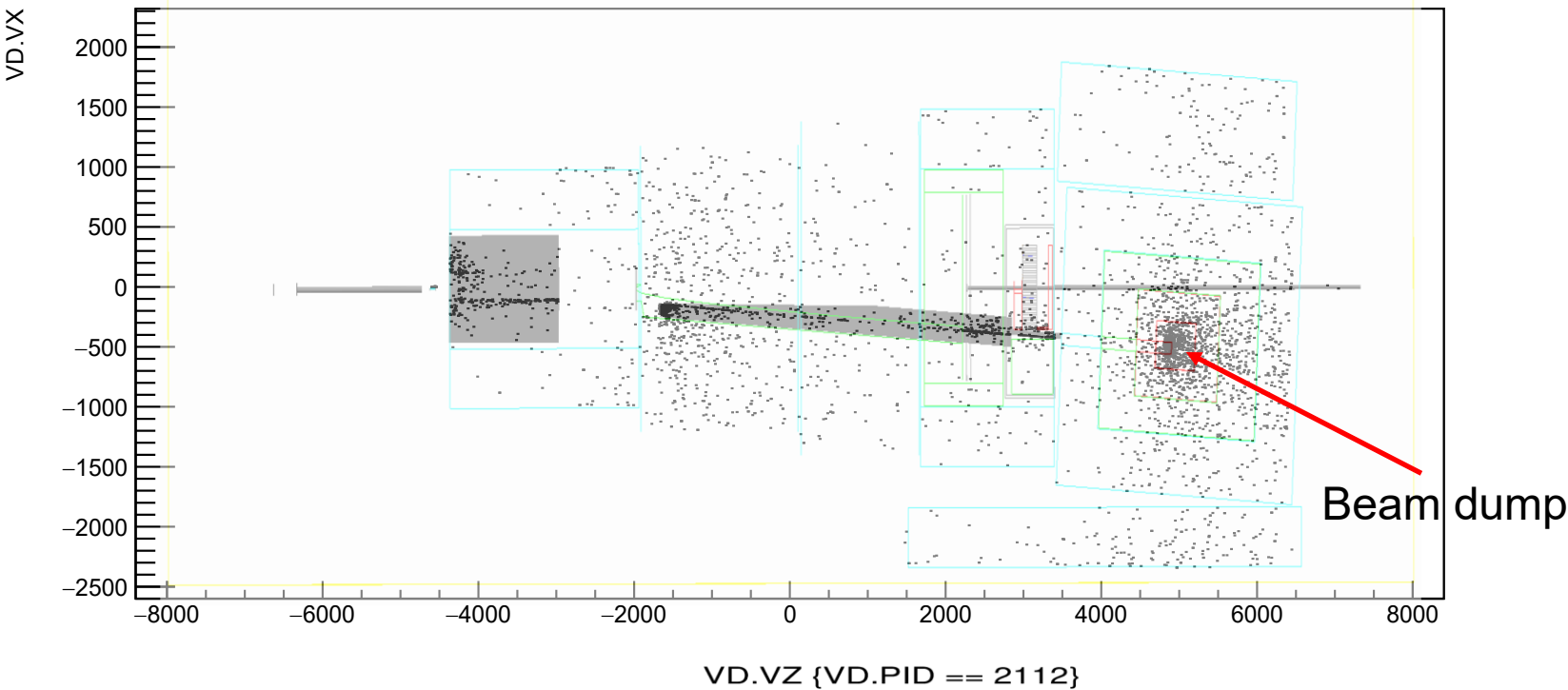

Local Beam Dump and Neutron Shielding

Simulation study done also by L. Zana from JLab Radcon group

The Geant4-based radiation analysis was found to be consistent with the FLUKA-based calculation performed by the Radcon group (Fig. 36). At a distance of 5 m, after 11-GeV 50-nA 15-days run the dose is below $0.7 \times 10^8 \text{ n/cm}^2$, so it is below to the benchmark level. Additional contributions from 2.2 and 4.4 GeV runs will increase the budget to $0.9 \times 10^8 \text{ n/cm}^2$.

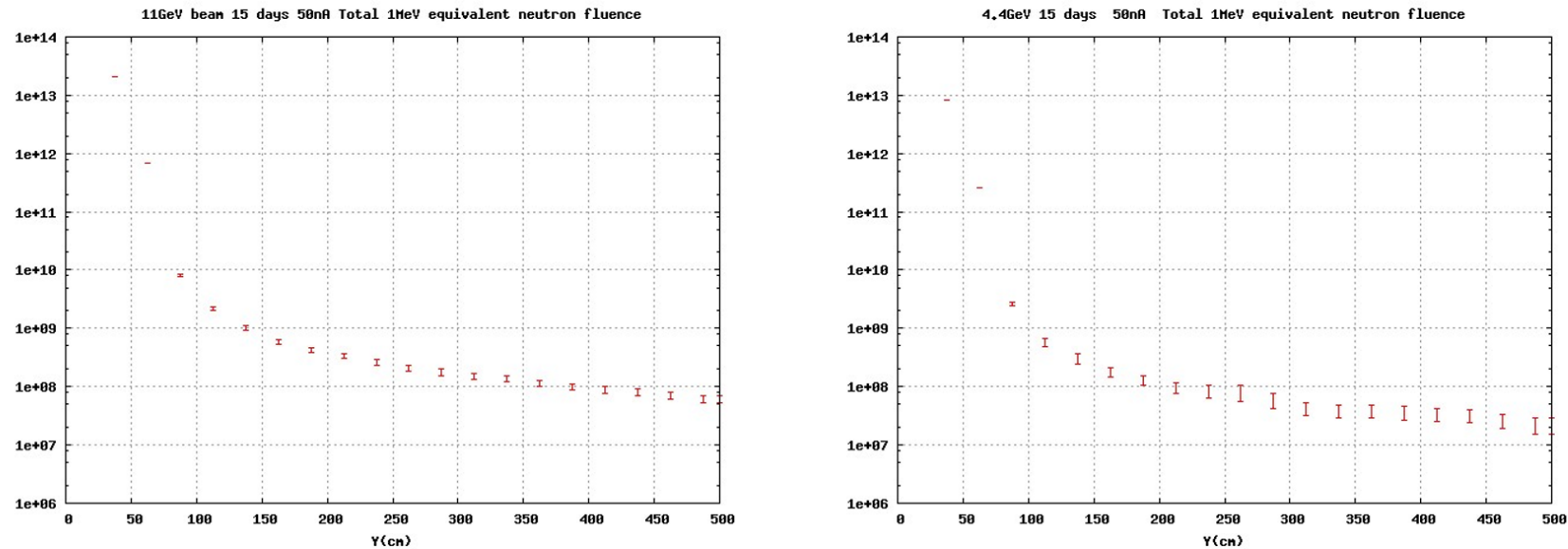
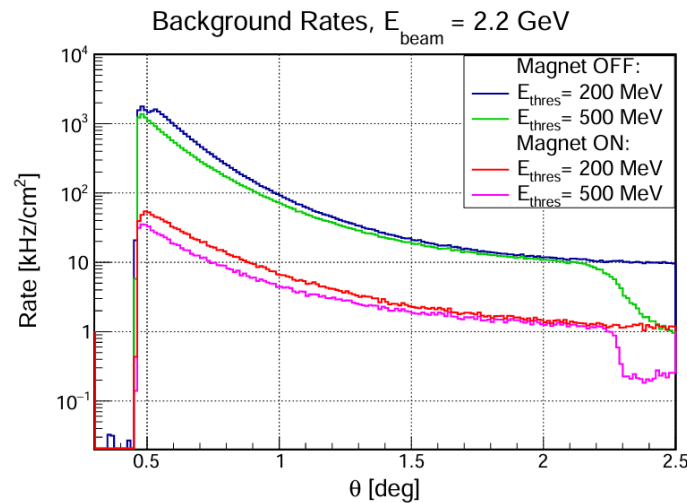
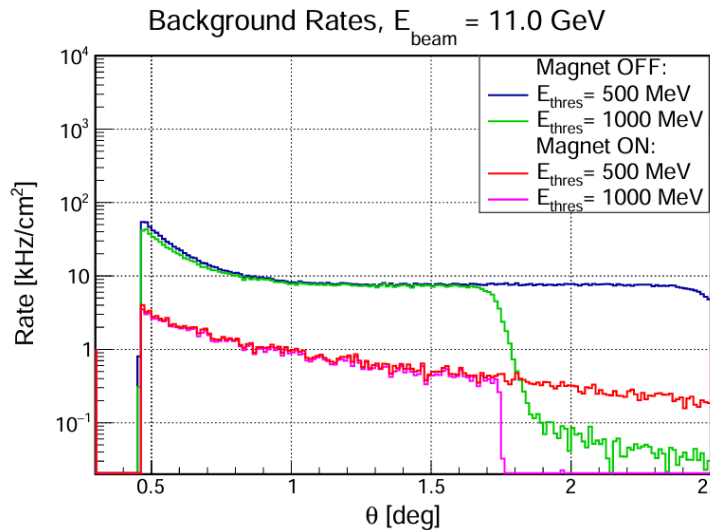

FIG. 36. Neutron radiation dose around the local beam dump vs. distance from dump center according to L. Zana in 4.4 GeV and 11 GeV parts of this experiment.

The value (10^8 n/cm^2) is 2000 times below the value recommended in the published studies of the radiation impact on the electronics.

Background Simulation

- Background distribution simulated with both physics generator and beam-on-target simulation with Geant4
- Results quite consistent
- Sweeper magnet reduces background rate by **factor of 10**



Luminosity $7 \times 10^{34}/\text{cm}^2/\text{s}$
 $\theta = 0.5^\circ - 2.5^\circ$

$E_b = 11 \text{ GeV}$, threshold 0.5 GeV

Whole M_{miss} acceptance, Total rate [Hz]

	Physics MC	Geant4-based MC
Sweeper OFF	1.9e+07	2.6e+07
Sweeper ON	1.8e+06	1.5e+06
Single γ -cluster	1.3e+06	1.4e+06

$E_b = 2.2 \text{ GeV}$, threshold 0.2 GeV

Whole acceptance, Total rate [Hz]

	Physics MC	Geant4-based MC
Sweeper OFF	1.4e+08	2.8e+08
Sweeper ON	1.6e+07	1.4e+07
Single γ -cluster	5.6e+06	3.6e+06

High Rate Capacity DAQ

- Expected cluster rate $\sim 20\text{MHz}$ for cluster energy $> 200\text{ MeV}$
- Require fADC250 and online filtering logic
- Resulting data rate $\sim 1.1\text{ Gb/s}$, well within limit

FADC Trigger path: Pulse detector/integrator

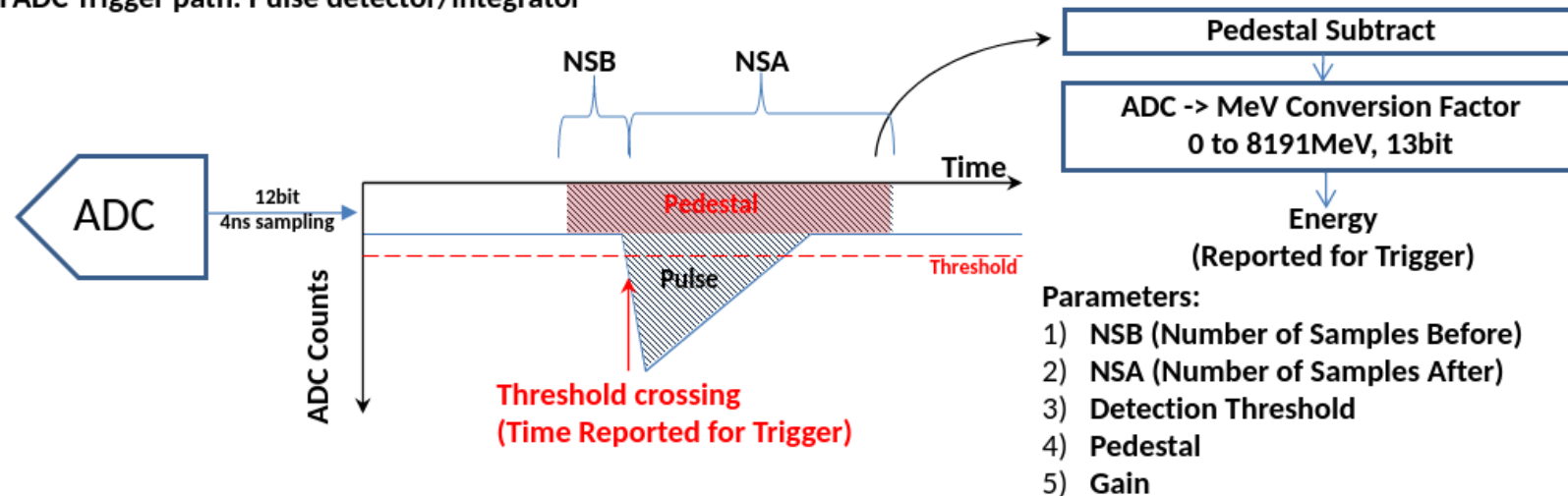

e.g. for seed threshold of 2 and hit $\Delta t = \pm 8\text{ns}$, the following hit pattern evolving in time will report 1 cluster:

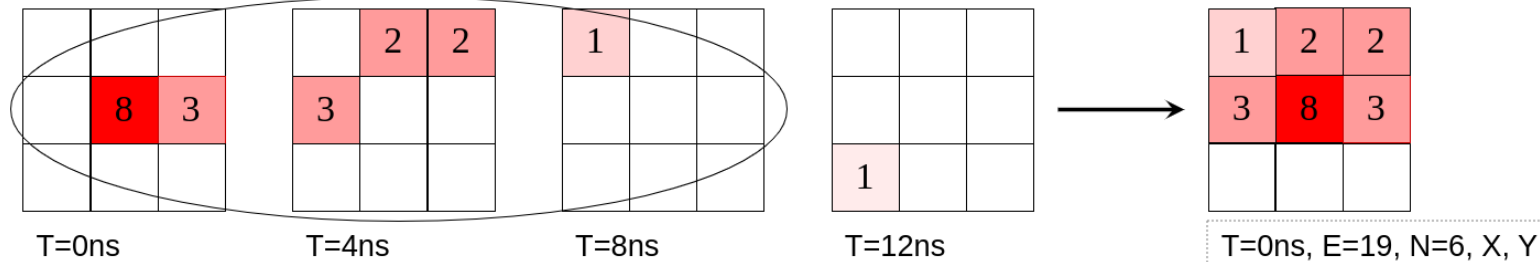

Invariant Mass Resolution

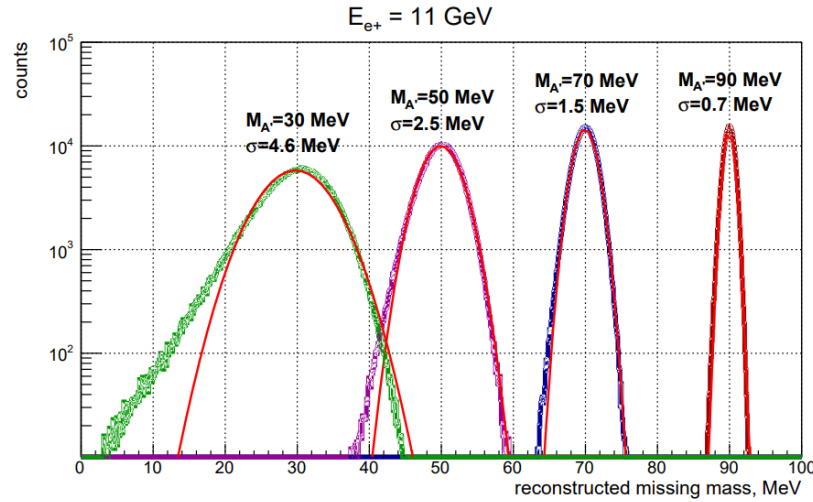

$E_{e^+} = 11.0 \text{ GeV}$ $M_A = 50$ and 80 MeV , single γ -cluster

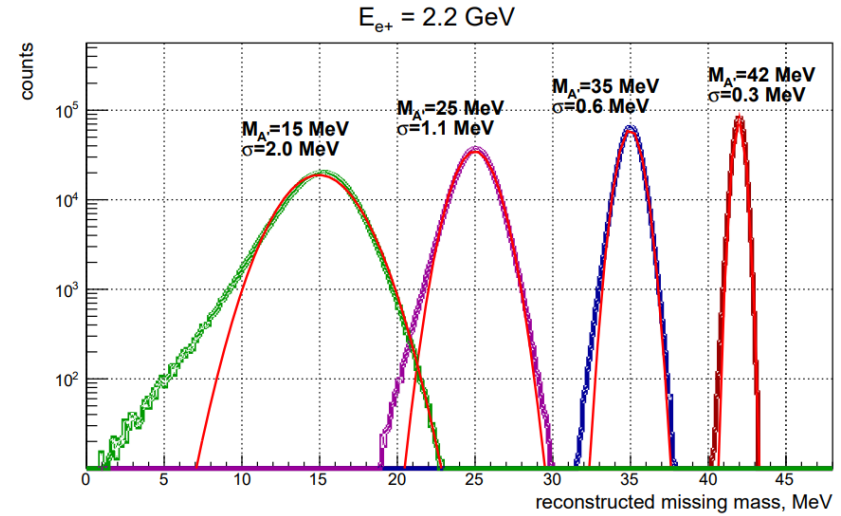

$E_{e^+} = 2.2 \text{ GeV}$ $M_A = 15$ and 35 MeV , single γ -cluster

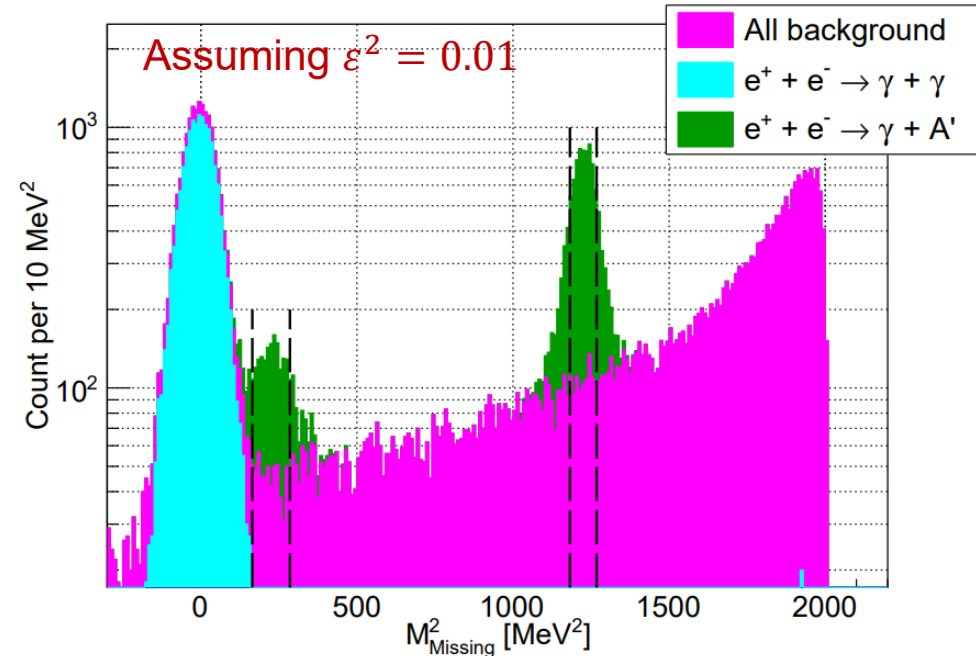
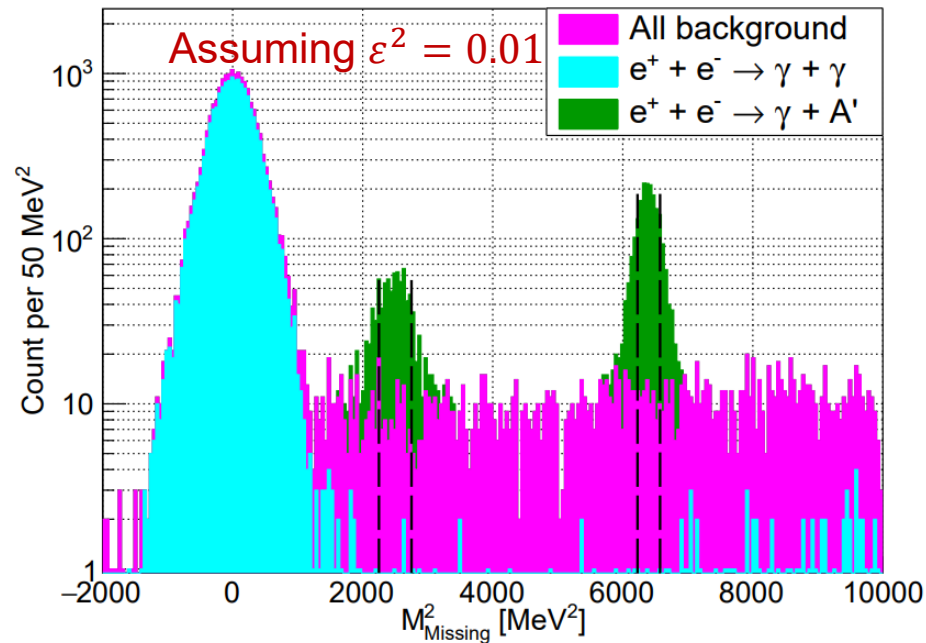

Projection

- Proposal approved (C1) with 55 days
 - 15 days for each of 2.2/4.4/11 GeV
 - 10 days for calibration and commission

Assuming $\varepsilon^2 = 1 \times 10^{-7}$

in the interval $M_{miss} = 35 \pm 1\sigma$, Events in 15 days

	Background	A'	$Signal/\sqrt{Background}$
Sweeper OFF	7.2e+11	5.6e+6	6.6 (resol. corrected)
Sweeper ON	1.0e+11	5.6e+6	17.7
Single γ -cluster	9.9e+10	5.6e+6	17.8

in the interval $M_{miss} = 80 \pm 1\sigma$, Events in 15 days

	Background	A'	$Signal/\sqrt{Background}$
Sweeper OFF	4.3e+10	1.3e+06	6.1 (resol. corrected)
Sweeper ON	1.1e+10	1.3e+06	11.9
Single γ -cluster	0.9e+10	1.3e+06	13.2

2.2 GeV

7.7 GeV

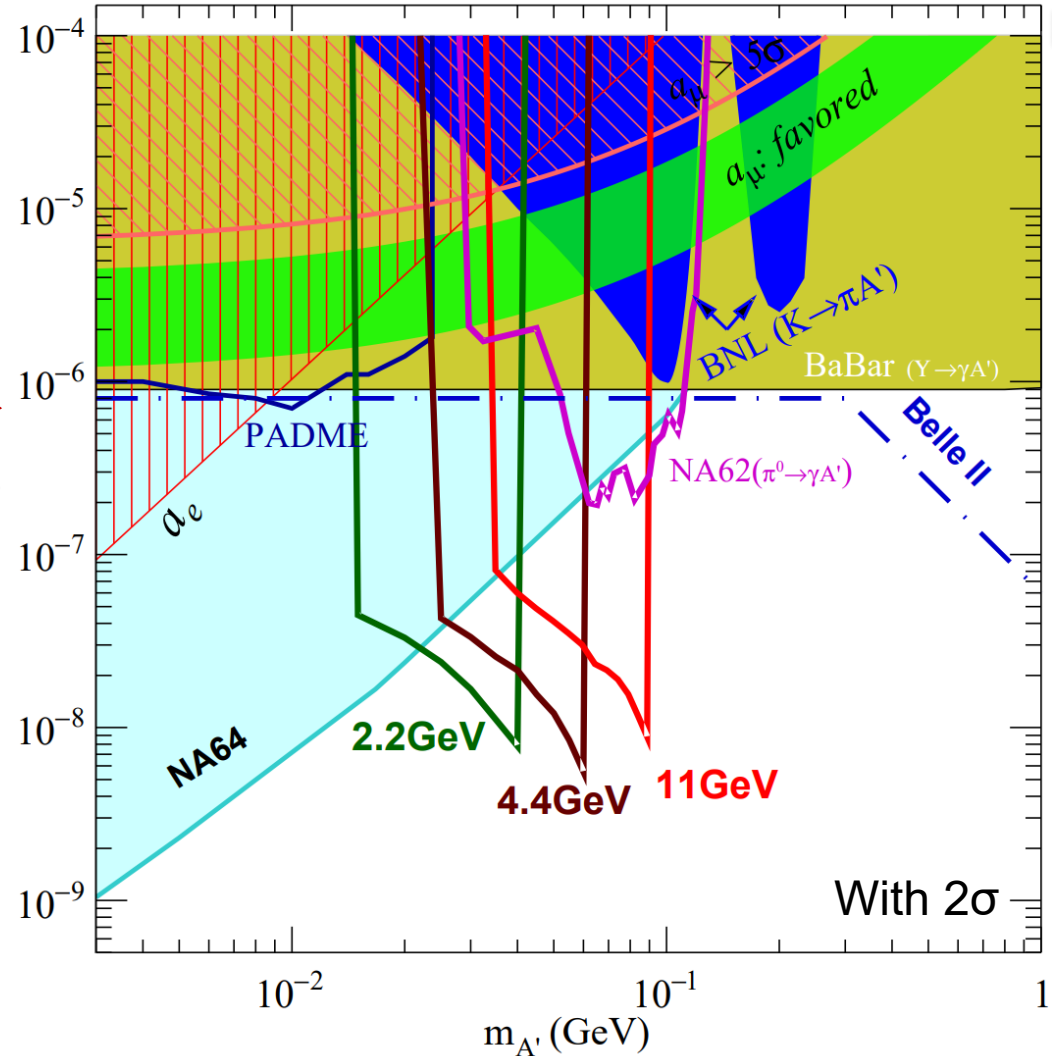

Potential DPS with LEEPP Program

- In fact, ideas of using e^+ beam at low energy have been around for decades, **though mostly not realized**:
 - A' search using JLab FEL proposal in 2006 (AIP Conf.Proc. 1160 (2009))
 - VEPP-3 A' search proposal in 2012 (JINST 13 (2018) 02, P02021)
 - A' search using very asymmetric e^+e^- collider (NIMA 1049 (2023) 168035)
- Only realized by PADME/INFN, but with limited luminosity
- Searching for A' in the \sim MeV region with 100-500 MeV high lumi. e^+ beam

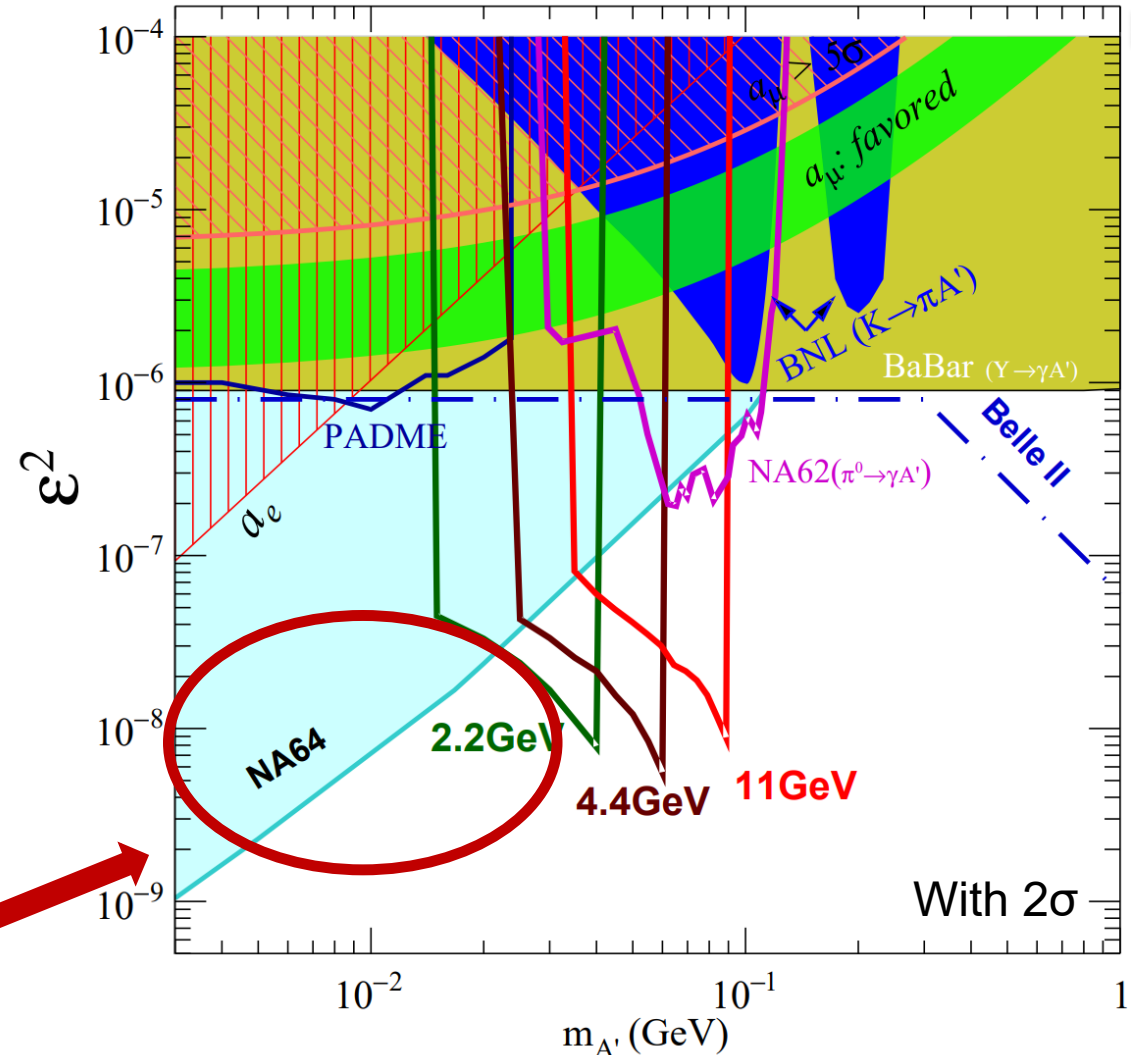

VEPP-3 Proposal - 2012

- A proposal to use e⁺ storage ring and internal target at Budker institute, Novosibirsk, Russia
- Positron beam up to 500 MeV, with 30 mA current
- Internal target with areal density $\sim 5 \times 10^{15}$ atoms/cm²
- Luminosity $\sim 1 \times 10^{33}$ /cm²/s

JINST 13 (2018) 02, P02021

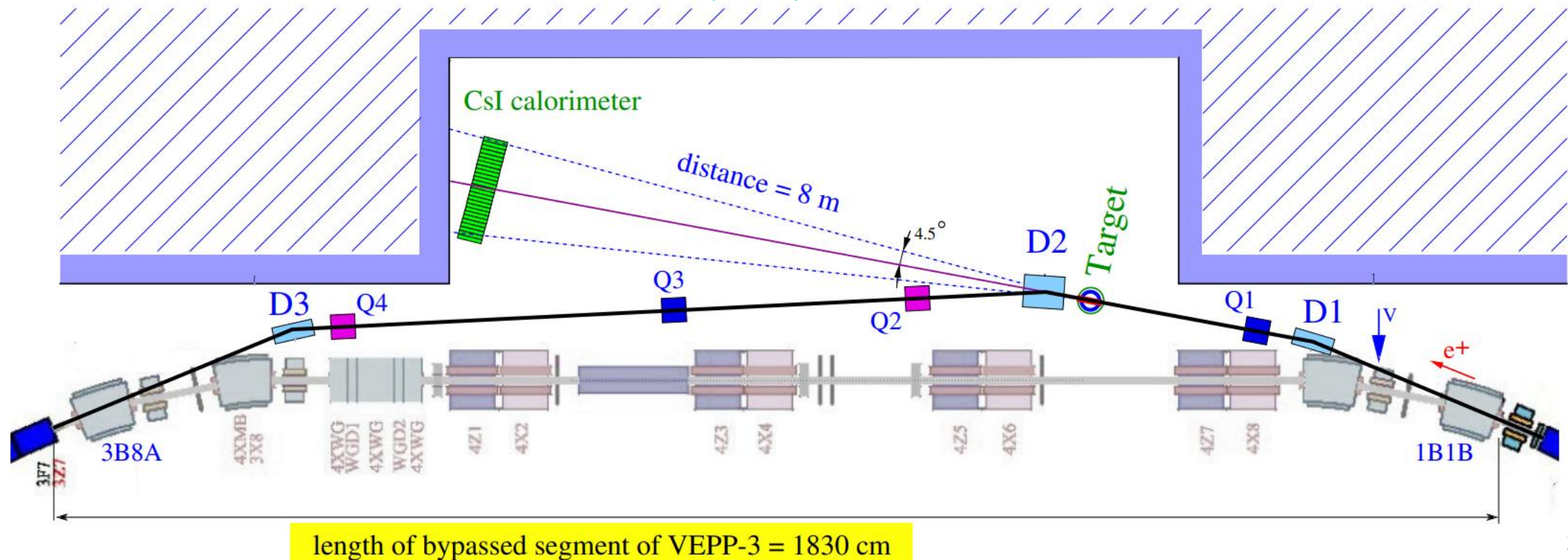

VEPP-3 Detector Concept - 2012

JINST 13 (2018) 02, P02021

- Experimental setup highly similar to the JLab C12+24-005 proposal
 - A sweeper dipole magnet
 - A High resolution CsI(Tl) EM-Cal: dimension $5 \times 5 \times 30 \text{ cm}^3$, $dE/E \sim 4\%/\sqrt{E}$, $dx \sim 12\text{mm}$
 - An additional veto detector (scint. strips + Shashlik EM-Cal) to reject backgrounds from bremsstrahlung and radiative Bhabha

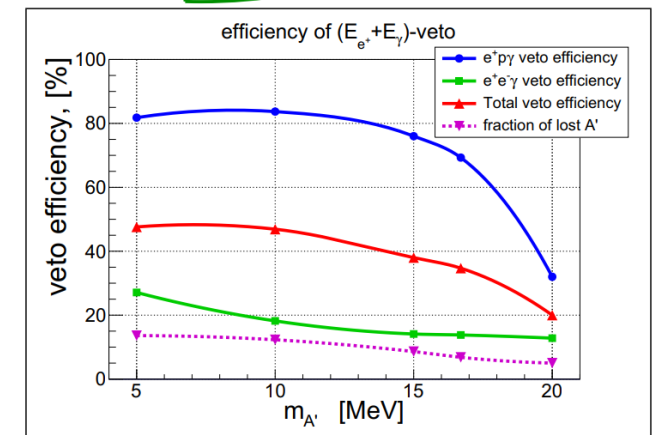
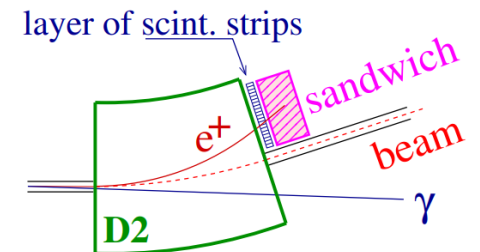
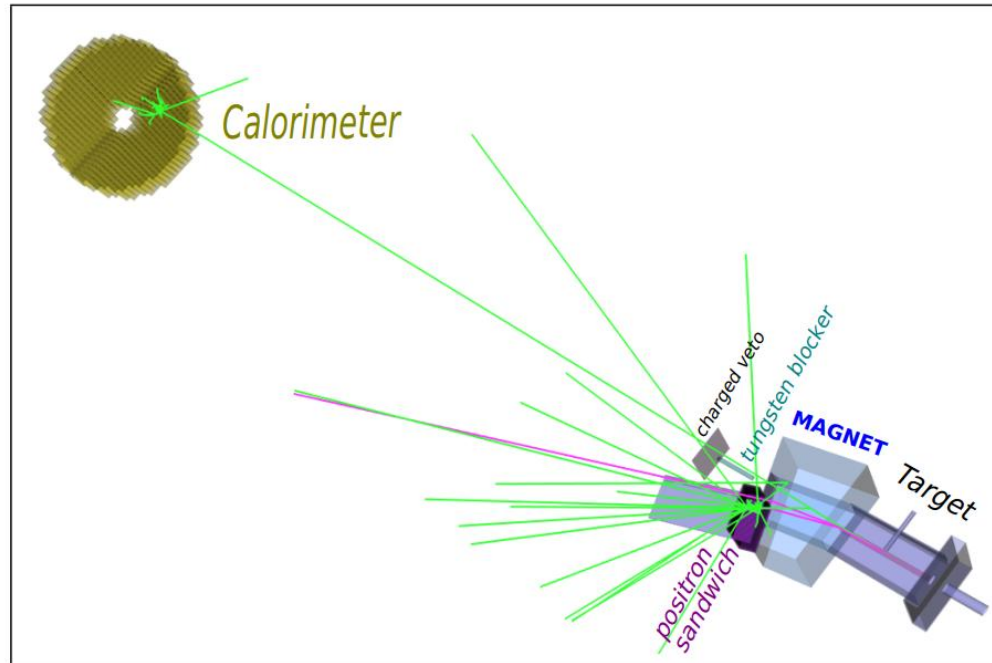
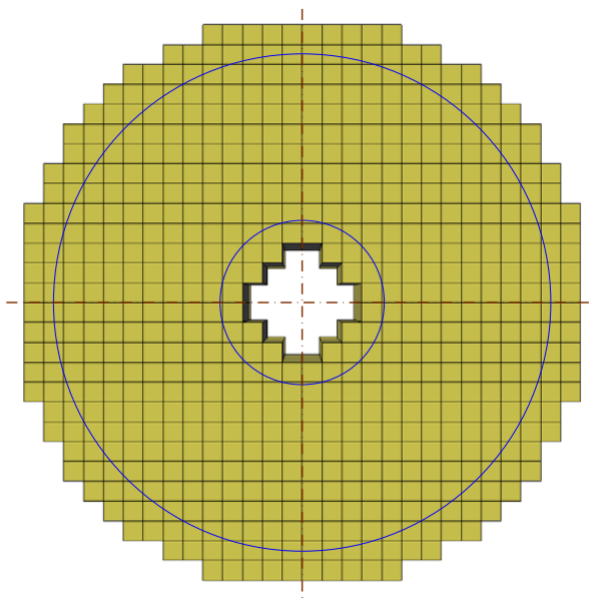

VEPP-3 Projected Results - 2012

- Positron beam up to 500 MeV, with 30mA current
- Internal target with areal density $\sim 5 \times 10^{15}$ atoms/cm²
- Luminosity $\sim 1 \times 10^{33}$ /cm²/s
- Half a year run with 65% time utilization
- Sensitive to A' in mass range between 5-20MeV, with sensitivity $\epsilon^2 \sim 1 \times 10^{-7} - 10^{-8}$

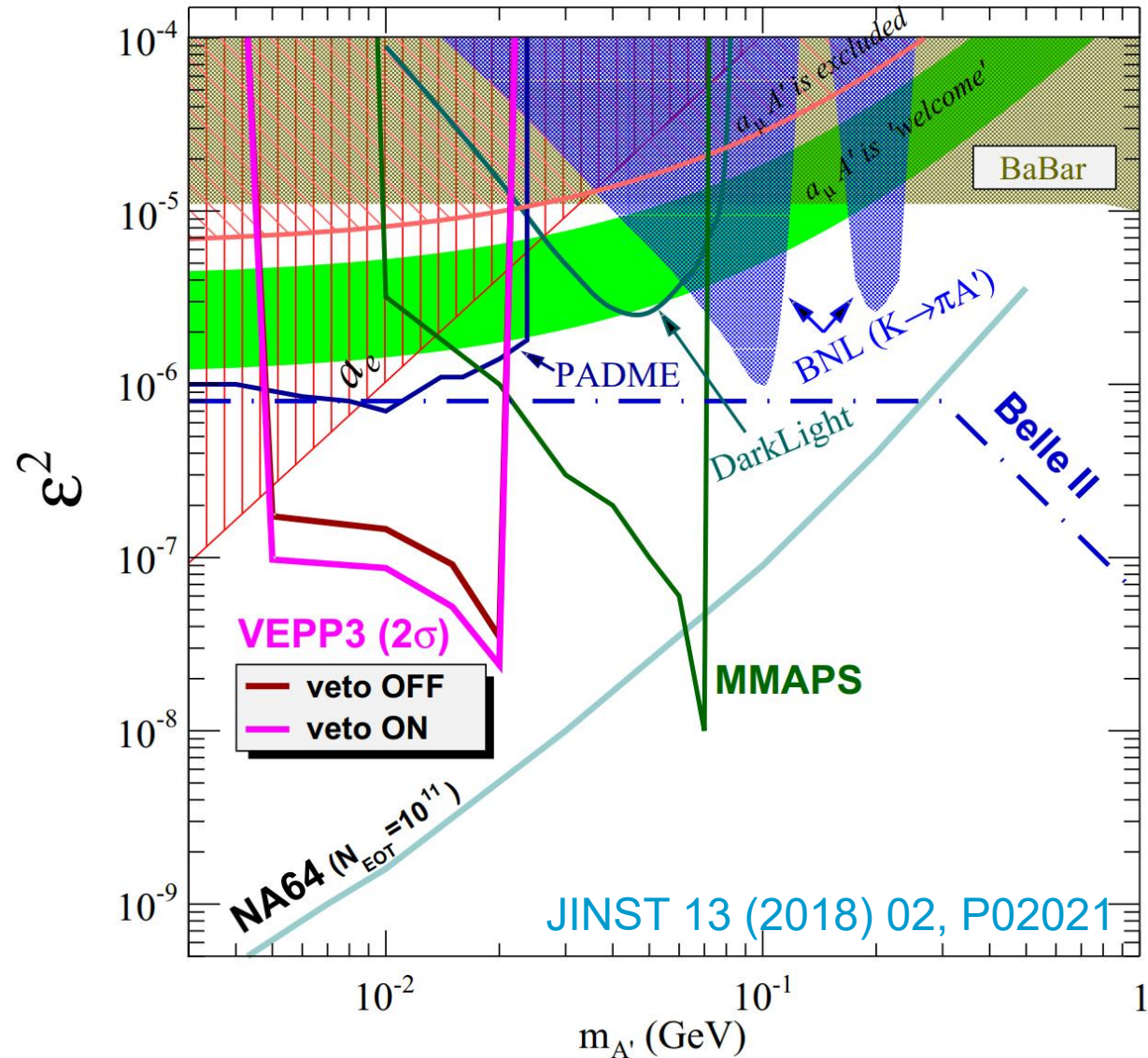

JLab FEL Proposal - 2006

AIP Conf.Proc. 1160 (2009)

- Positron beam ~ 200 MeV, with 50 nA current
- 1cm LH2 target
- Luminosity $1-2 \times 10^{34}$ /cm²/s
- Can be done with existing PRIMEX/PRad setup
- One month for data taking
- Sensitive to A' in mass range between **2-12 MeV**, with sensitivity $\varepsilon^2 \sim 1 \times 10^{-6}$

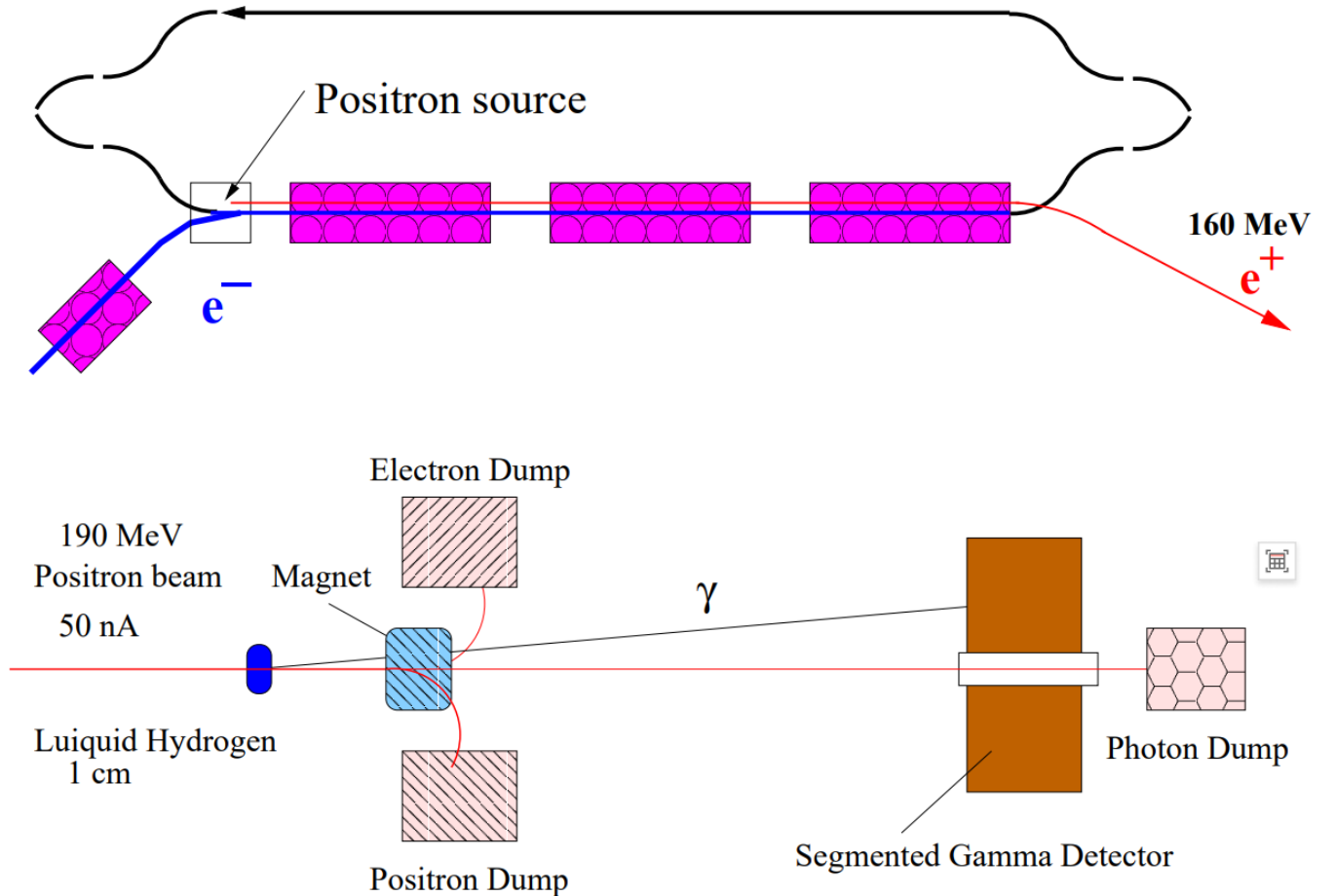

Potential New Proposal 2026

- New proposal similar to VEPP-3 and JLab FEL can be developed quickly
- Similar technique, based on existing PRIMEX/PRad HyCal
- Positron beam 100-500 MeV, with 50 nA current
- 1-5cm LH2 target
- Luminosity $1-7 \times 10^{34}$ /cm²/s
- ~4 months of data taking
- Sensitive to A' in mass range between **1-20 MeV**, with sensitivity $\epsilon^2 \sim 5 \times 10^{-8}$

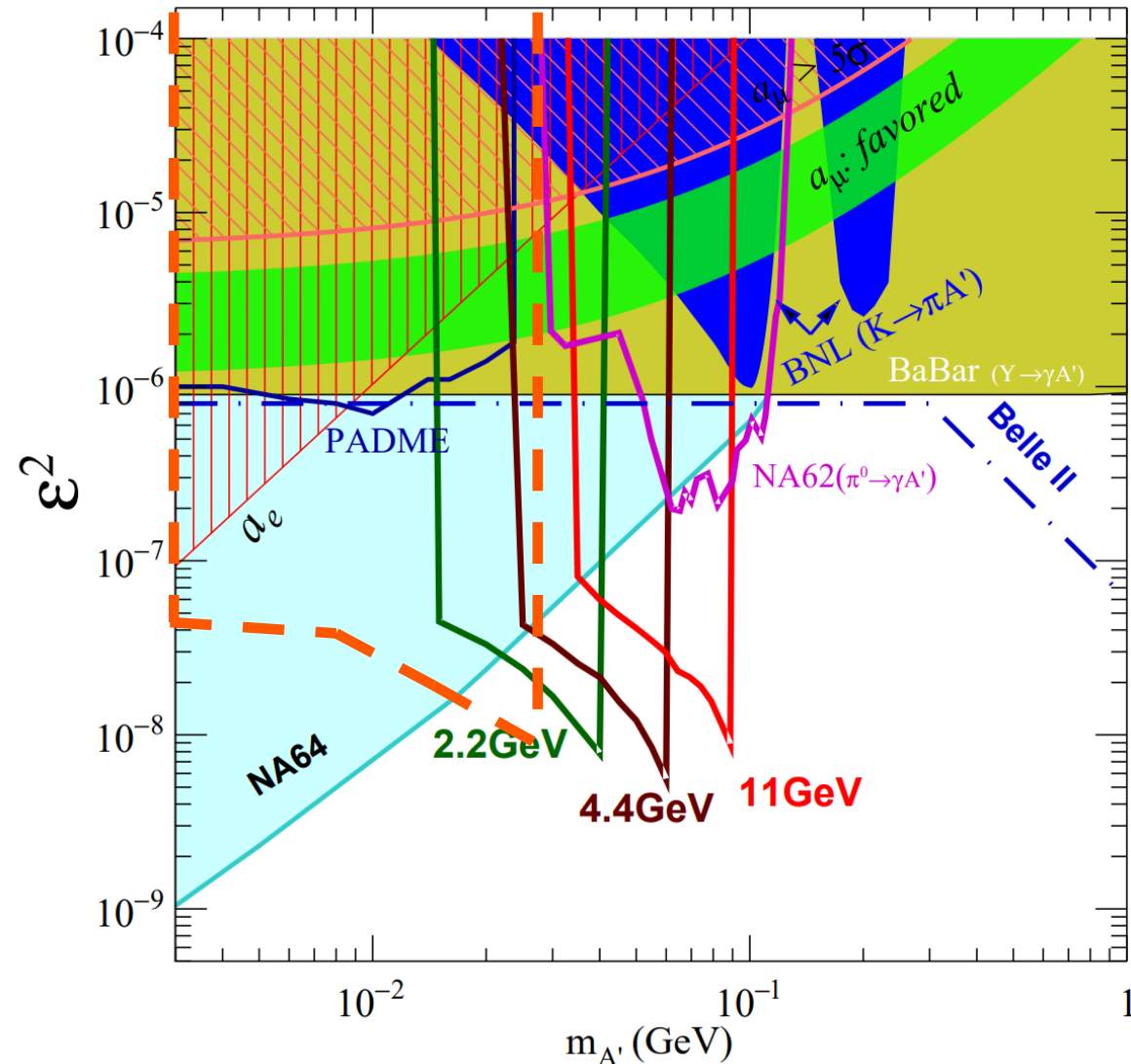

Summary

- A method to search A' using positron beam will be productive:
 - Require positron beam annihilating with atomic electron of hydrogen
 - Searching for A' independent of its decay mode
 - Detectors mostly based on existing apparatus from PRIMEX/PRad
- Proposal (C12+24-005) for CEBAF based experiment approved by PAC52 with rating A- for 55 days
 - C1: depending on e^+ beam availability
 - 3 beam energies, 2.2/4.4/11 GeV, each with 15 days of beam time
 - Sensitive to A' in mass range 15-90MeV
 - High sensitivity $\varepsilon^2 \sim 1 \times 10^{-8}$
- Same idea can be extended to lower mass region (i.e. A' mass 1-20MeV) with positron beam at a few hundred MeV

Backup

VEPP-3 Proposal – 2012

- Missing mass resolution better than 2 MeV for A' mass in range 5 -20 MeV
- Could be improved with HyCal PbWO4 modules, ~ 2 times better energy and positron resolution

Missing Mass

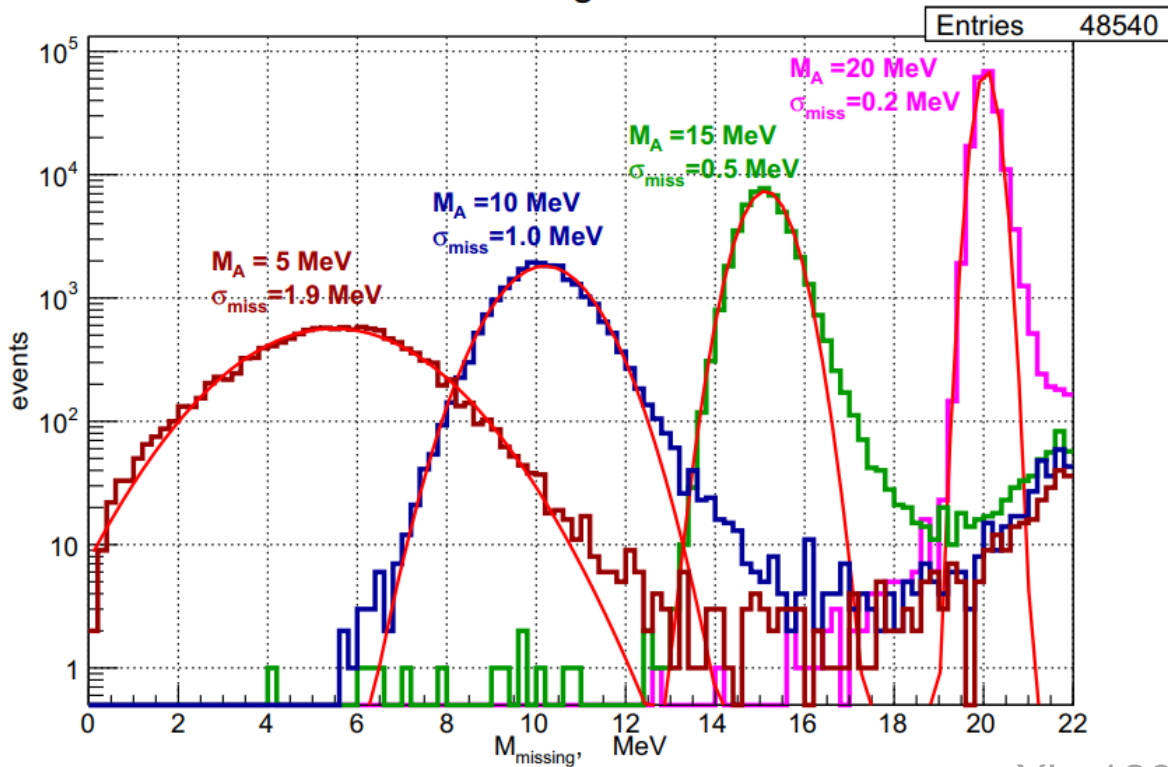

Assuming $\varepsilon^2 = 0.01$

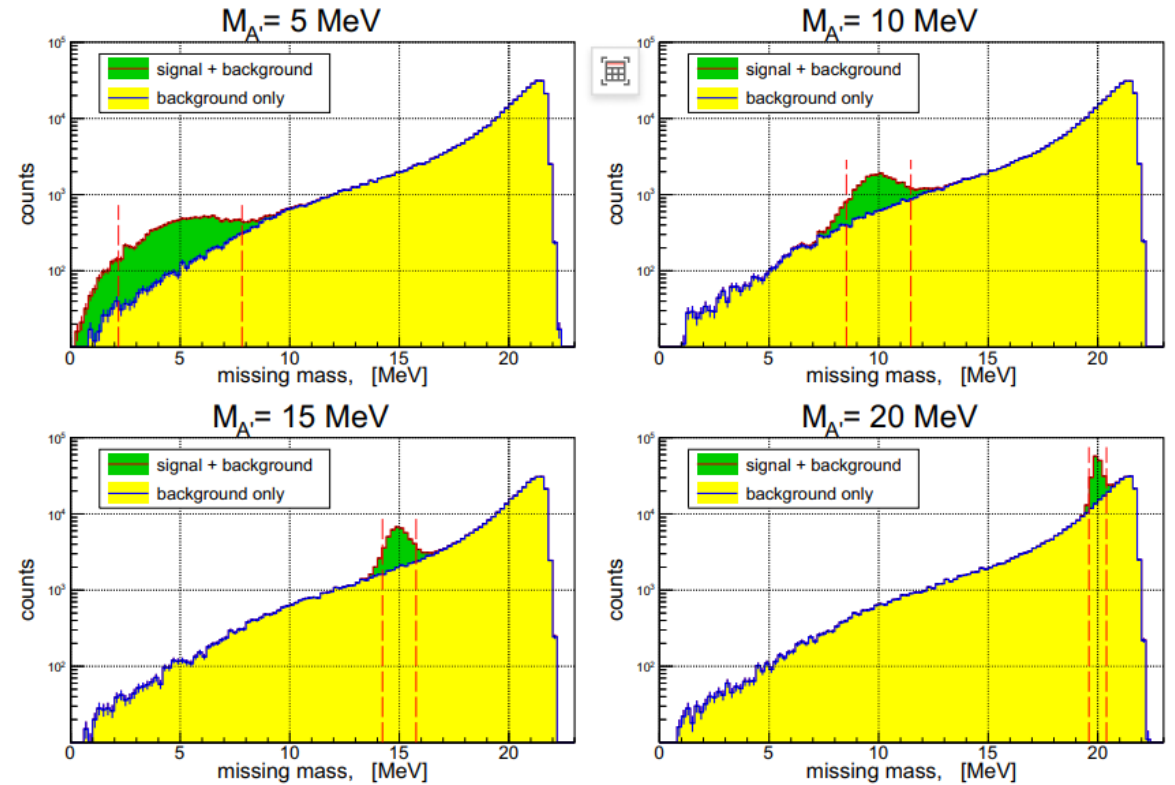

arXiv:1207.5089v1