

GHP Meeting: News from Jefferson Lab

David J. Dean

Deputy Director for Science and Technology

Presented To:

GHP Group at the APS Conference

March 16, 2025

Outline...

- Broad Strategy Discussion
 - Executing an excellent science program
 - Actively planning for the future
 - AI Strategy
 - Other News
- 

Laboratory strategy incorporates three key areas

- Nuclear Physics
 - CEBAF serving our user community in the quark sector
 - EIC serving our user community in the gluon sector
- Computational and Data Science
 - Delivering HPDF to accelerate scientific discovery and innovation
 - Developing a related R&D program
- Accelerator Science and Technology
 - Innovation for reliable SRF accelerators, and training the next generation of accelerator scientists

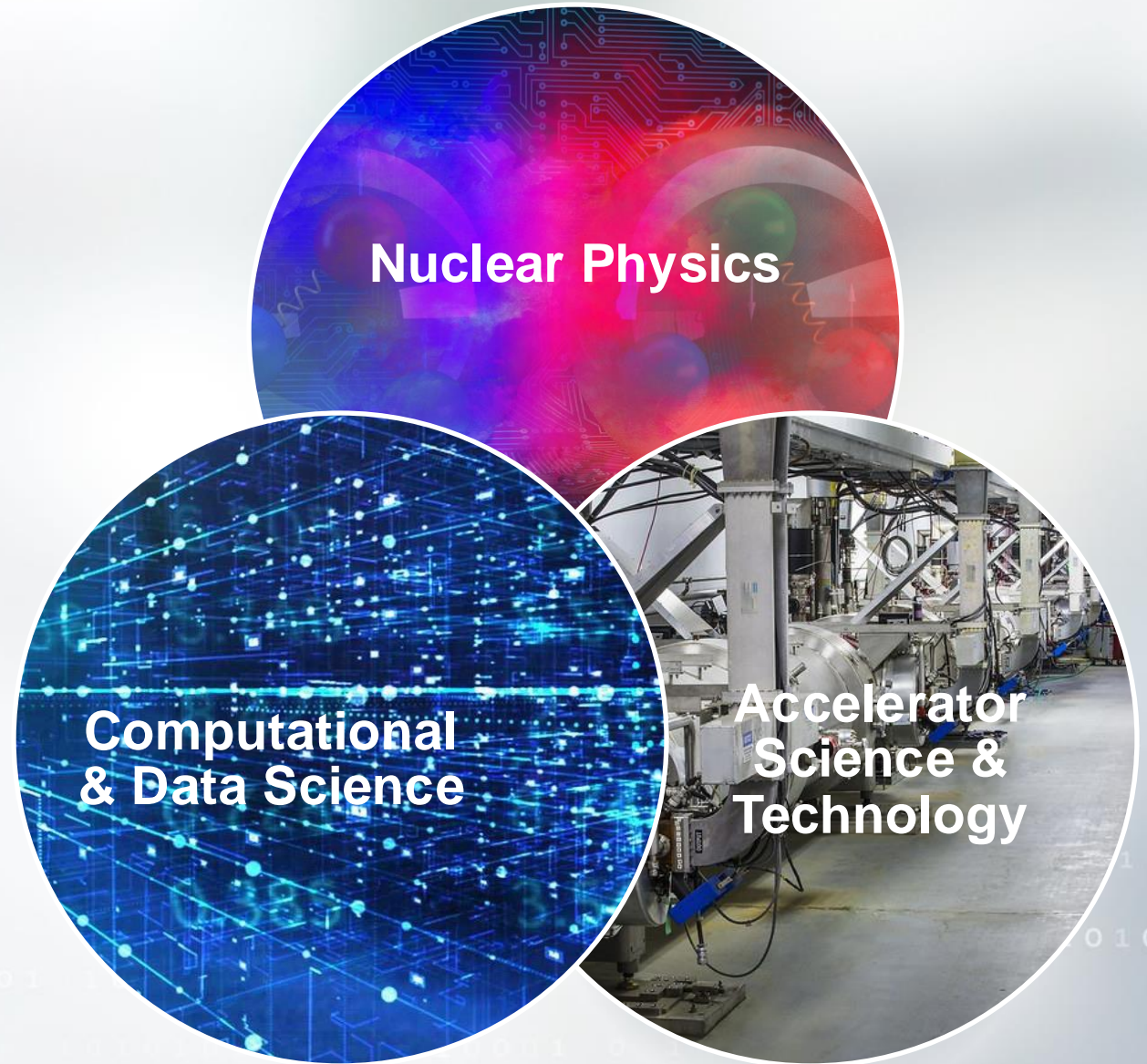

Nuclear Physics: Key scientific challenge

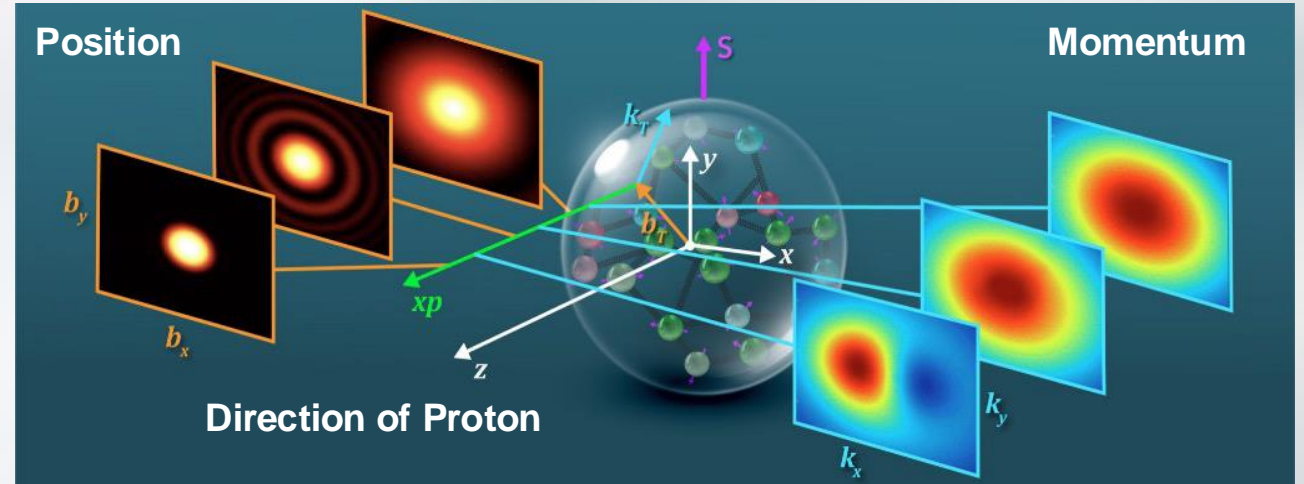
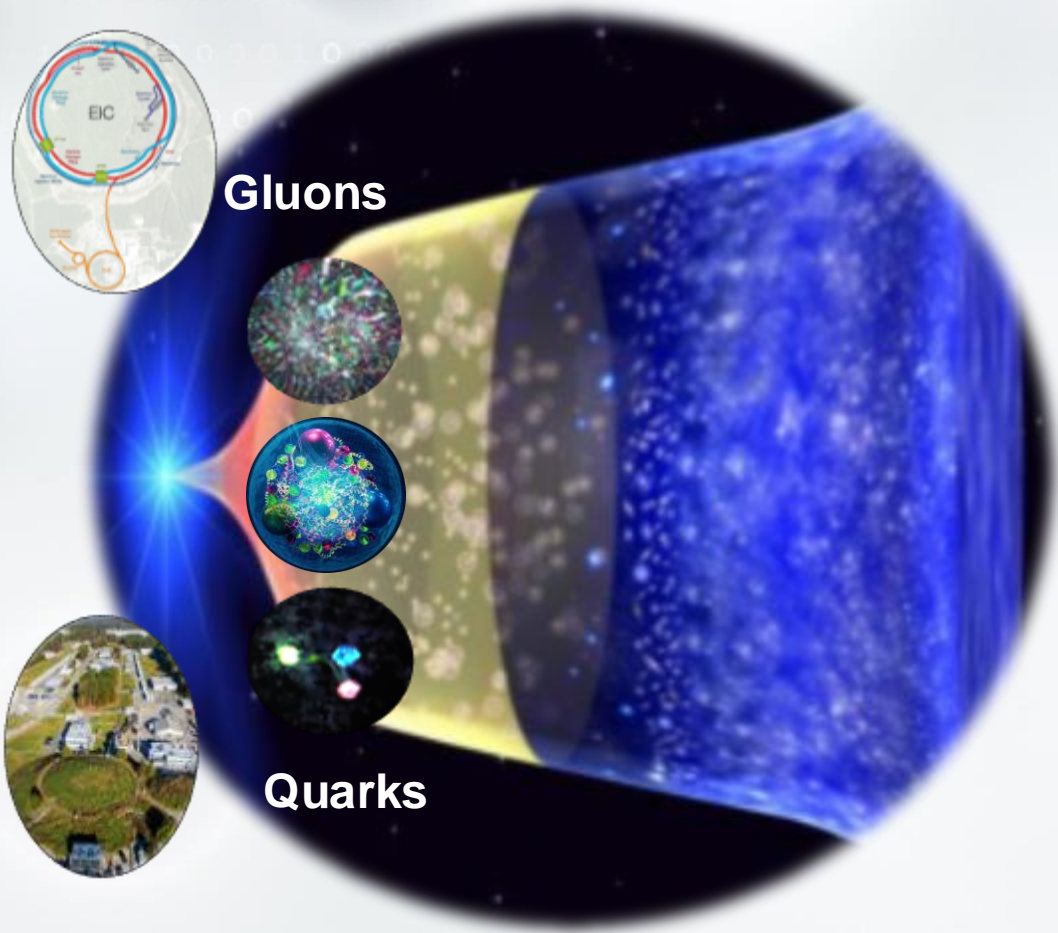

How do quarks and gluons make up protons, neutrons, and, ultimately, atomic nuclei?

The ability to reduce everything to simple fundamental laws does not imply the ability to start from those laws and reconstruct the universe. -- *More is different*, P. W. Anderson [Sci 177, 393 (1972)]

Full steam ahead on CEBAF science

- Proton properties – Example: Electromagnetic form factors
- Proton properties in the nucleus – Example: Deformation of the form factors in medium
- Quark and gluon distributions in the proton: Example: Generalized Parton Distributions
- Quark and gluon distributions in a bound proton: Example: modified GPDs
- Quark and gluon distributions in other hadrons (pions, Kaons)
- Exotic particles (pentaquarks, glue-balls,...) and molecular states
- Theory developments to guide and interpret experimental results

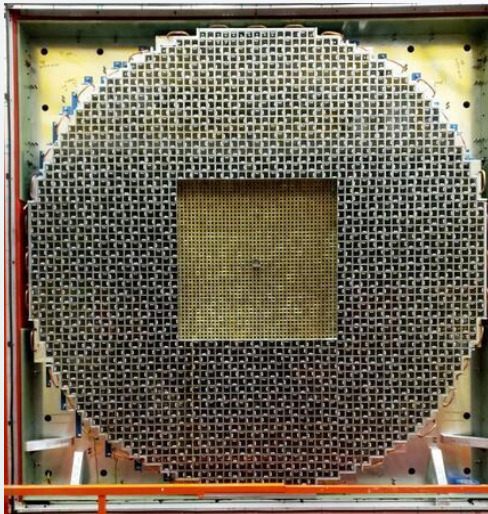

Major upgrade to GlueX detector

- Removed 400 Lead Glass modules
- Inserted 1600 PbWO₄ modules

- 2x resolution increase
- Additional Radiation hardness

Electromagnetic form factors

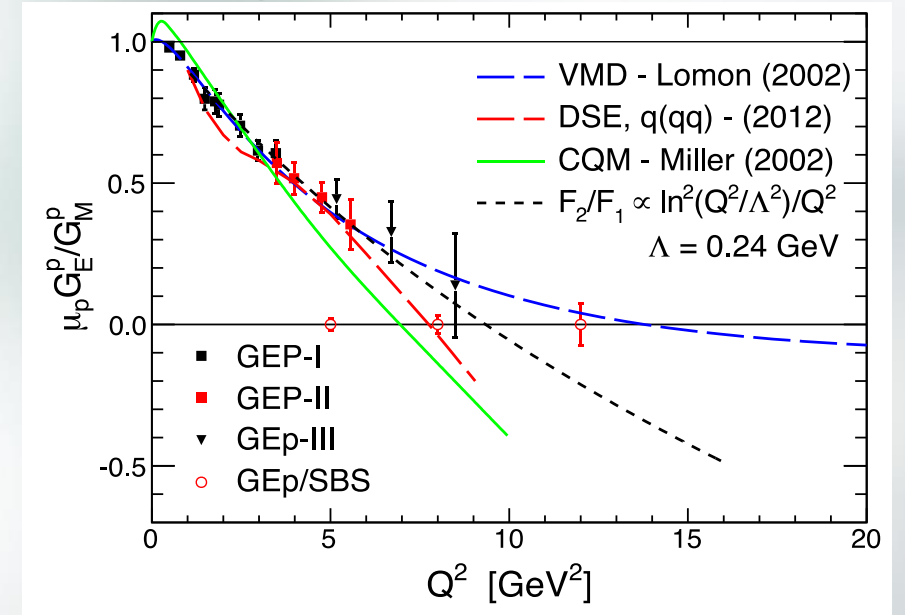

Photoproduction of $\gamma p \rightarrow a_2(1320)^0 p$

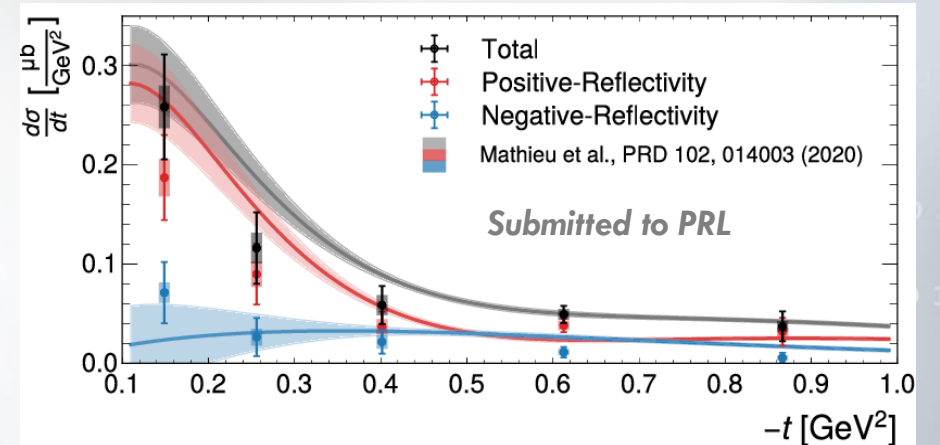

Preparing the next generation: Pia Jones-Petrak (NL SLAM)

What particles are there?

electron
atom
gluons & quarks
proton
theory
GlueX experiment

A woman in a dark blazer stands on a stage, pointing towards the large screen displaying this diagram. The audience is visible in the foreground.

TJNAF enables 1/3 of all US PhDs in nuclear physics; These are among the best people in the world and are well prepared for driving the future.



The next large scale detector: SoLID

SoLID will maximize the science return of the 12-GeV CEBAF upgrade by combining high luminosity (10^{39} e/cm²/s) with large acceptance (full azimuthal)



How do quarks and gluons contribute to the proton spin?



How do quarks and gluons contribute the proton mass?

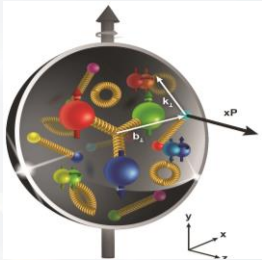

How are quarks and gluons distributed inside the proton?

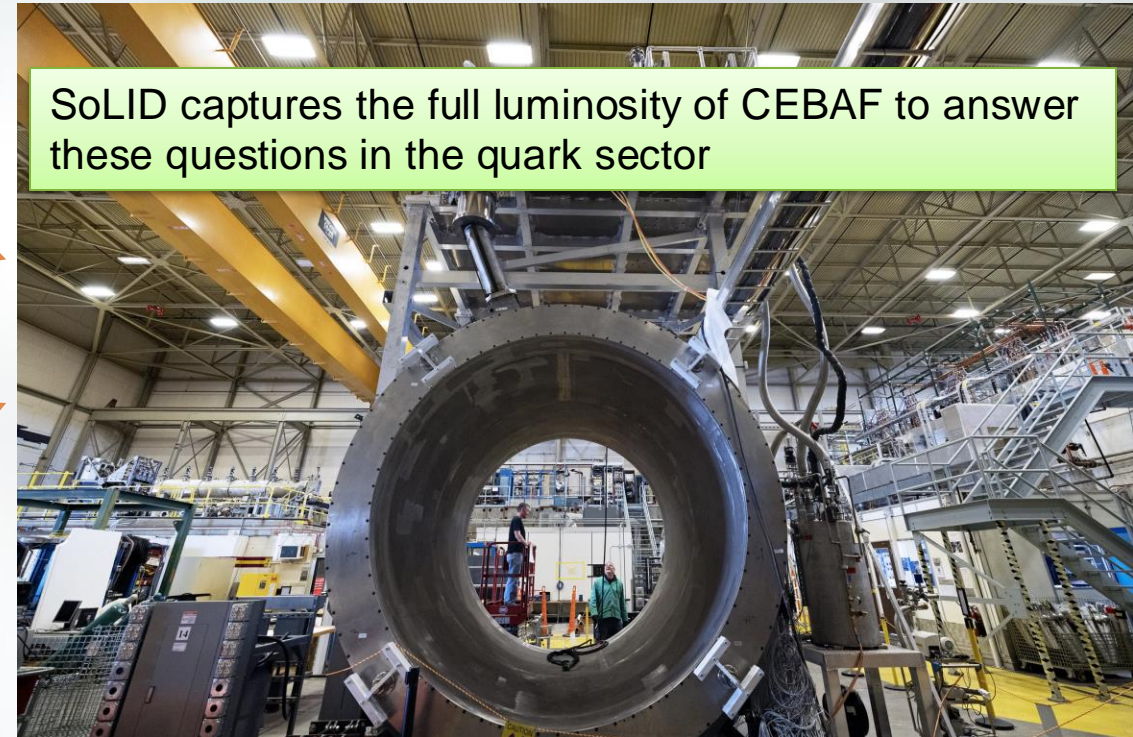

SoLID captures the full luminosity of CEBAF to answer these questions in the quark sector

Two science pillars of the SoLID (**proton spin** and **mass**): high-luminosity valence quark tomography and precision J/ψ production near threshold (EIC in the sea/gluon region, **both needed!**)
Parity violating deep inelastic scattering: tests of Standard Model & search for new physics

Future Upgrade paths: Positrons

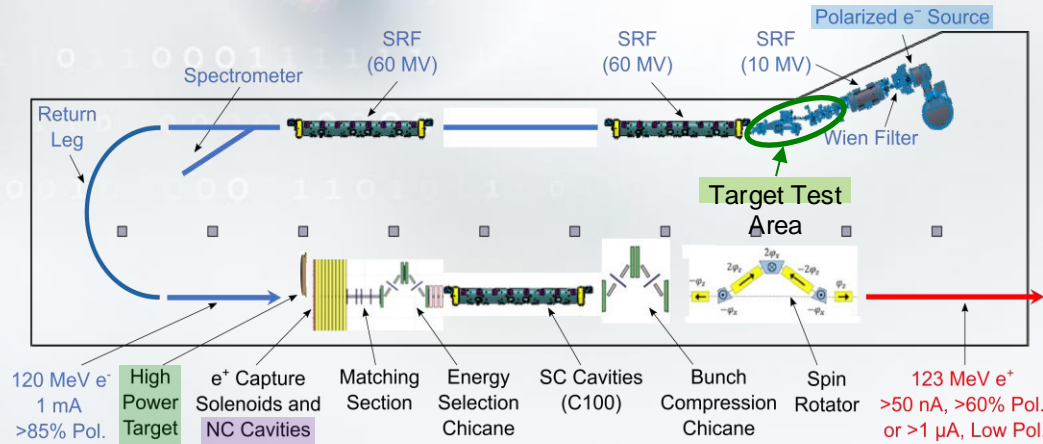

mA e⁻ Photogun

- High current e⁻ source (<10 mA @ 10 MeV)
- Up to 90% polarization
- Long life time

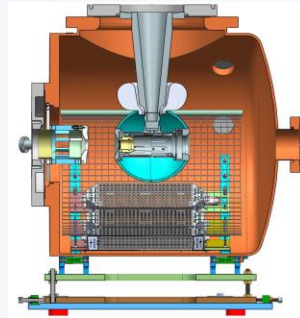

2 years of PAC approved experiments

JLAB NP R&D

- 2.5 FTE Accelerators including Gruner fellow
- Support Degradar (former LDRD) to quantify CEBAF acceptance

LDRD program

- 2-year - test improvements for high-intensity (mA) polarized photogun
- 3-year - strategic hire of positron model integrator role

NP FOA

- 2-year - NP Futures concept of Tungsten Solid Target, CFD, Prototype Testing
- 2-year (SBIR) concept of GalnSn Liquid Target, Prototype Testing at LERF

HEP FOA

- 3-year – US-Japan collaboration with SLAC/KEK to exchange e⁺/e⁻ source concepts

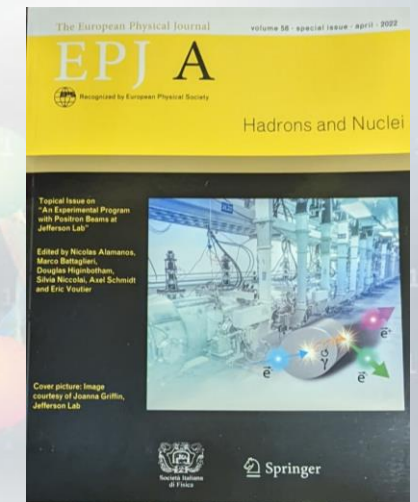
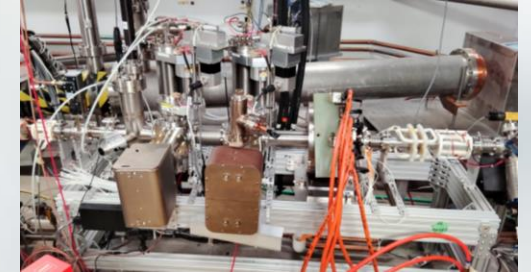

22 GeV upgrade: formulating the baseline (pre TDR/CDR)

All in time for the next LRP

1

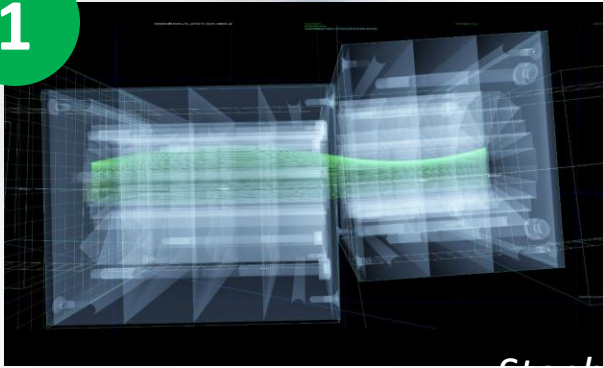

- Imported a vendor's magnet mechanical design and overlaid it on the beam orbits to make sure there is **clearance**

Stephen Brooks

2

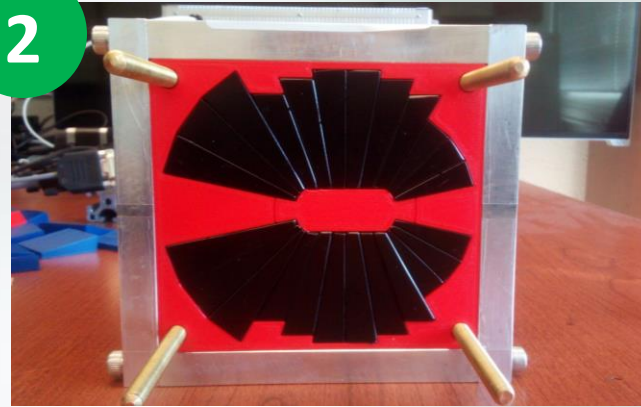

- Prototype open-midplane BF magnet successfully built and evaluated for **mechanical integrity**
- >1.5 Tesla measured in good field region
- Field accuracy of 10^{-3}

Installation map in CEBAF – 30 installation locations of varying dose and radiation type (gamma vs. neutron)

3

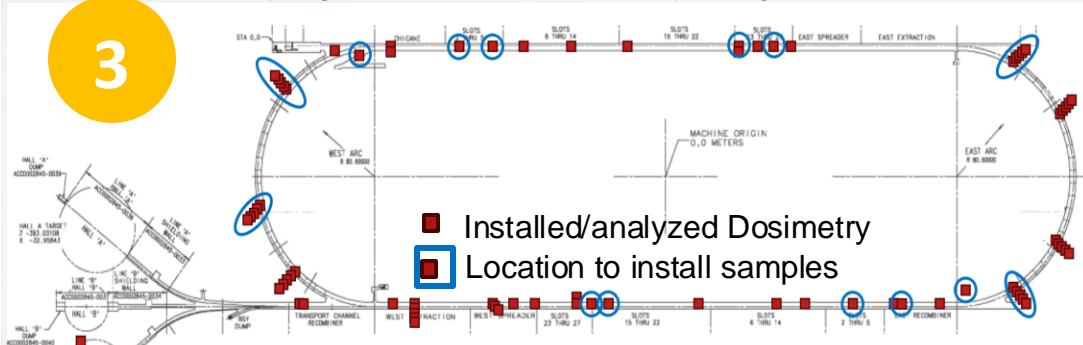

Resiliency studies of permanent magnet materials in a radiation environment at CEBAF resembling their intended operational one (**LDRD project started Oct. 1, 2023**)

March 16, 2025

4

Construction of a full-length permanent magnet (LoI to DOE)

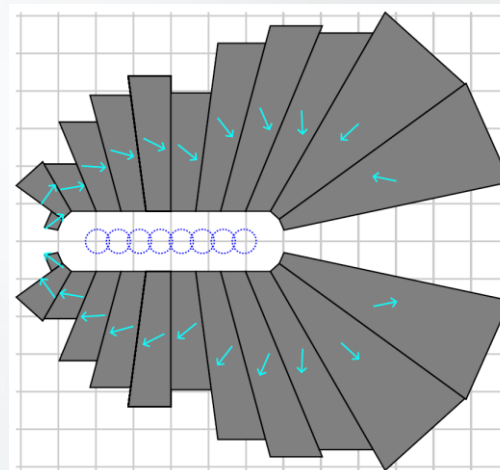

Hall C - possible location of the **Test**

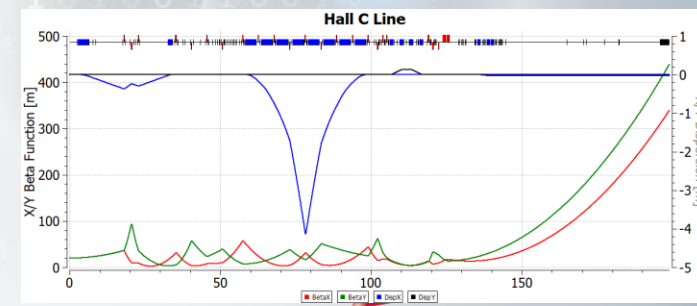

EIC Partnership: Refine EIC Project

- Project is executing CD-3A procurements
- OPA Review in January recommended CD-3B
- Resource Review Board has generated a lot of interest and international commitment
- Project is developing a subproject approach in moving to CD-2/3
- Dean and Deshpande recently charged the ePIC collaboration to identify exciting early science results...

Science Program starts after Subproject 3 is complete.

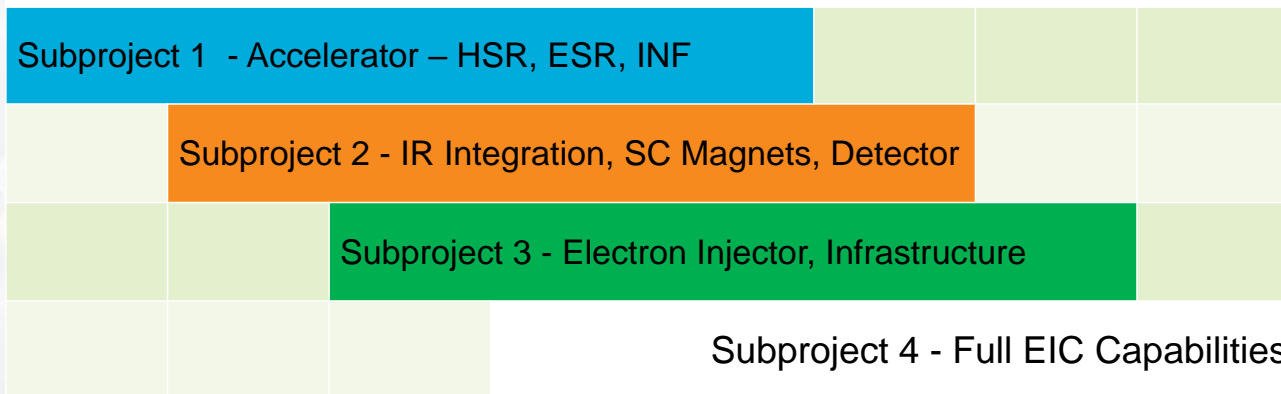

J. Yeck overview talk at OPA review (January)...it is evolving quickly

March 10, 2025
Subject: ePIC Collaboration: Early Science Document

John Lajoie and Silvia Dalla Torre
Spokespeople, ePIC Collaboration

Dear John, Silvia and the ePIC Collaboration,

As the EIC construction plan becomes more mature, it is apparent that there will be a period of about five years when there will be collisions at the ePIC detector for commissioning and early data could be recorded. The EIC Project team has released their expectations for the beam parameters (polarization, luminosity, energy and nuclear species) during that early operating phase. We are writing to you - the ePIC collaboration - to develop a concise document summarizing the science that would be possible from those early data.

Based on the early commissioning beam parameters released by the EIC project [1,2], the ePIC collaboration should summarize for the broader nuclear physics community, the funding agencies, and for the Labs, what exciting scientific results would be possible from this early EIC operation.

"Identify for the broader scientific community, the funding agencies, and the Labs, what exciting scientific results would be possible from this early EIC operation."

previous such exercises (like the yellow report) were focused on full EIC machine capability. This report should focus on the science that will be produced during the time of commissioning and before the ramp up to the full EIC machine capability.

We suggest that you provide this report by 1 October 2025. We would be happy to have a kick-off meeting as this process gets underway.

Sincerely,
David Dean (Deputy Director, Jefferson Laboratory)
Abhay Deshpande (ALD, Nuclear and Particle Physics, Brookhaven National Laboratory)

[1] Elke Aschenauer for the EIC project: [presentation at the ePIC Meeting](#), January 2025
[2] Rolf Ent for the EIC project: [presentation at the POETIC 2025](#), February 24-28, 2025

MOLLER: World-leading Measurement of Lepton-Lepton Electroweak Reaction

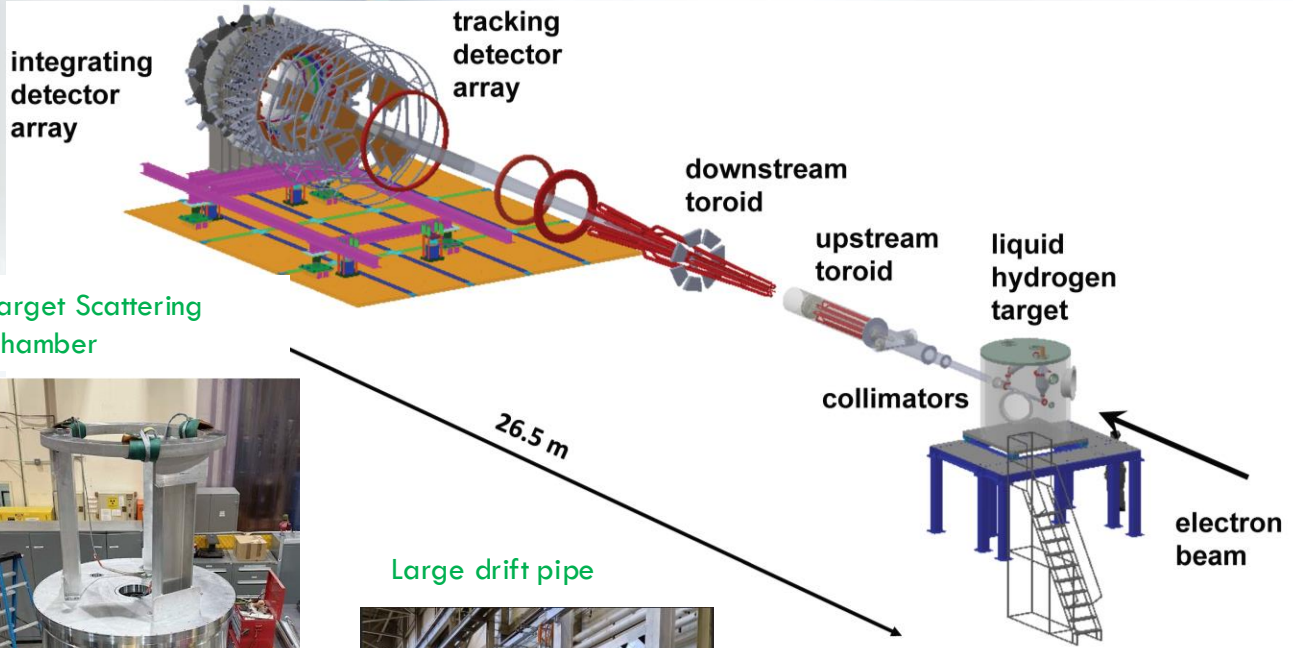

- The most precise measurement to date of the **parity violating asymmetry, A_{PV}** , in electron-electron scattering, and thus the weak charge of the electron.
- Experiment requires extremely high signal rate and very low noise (Parity violation will be measured to 26 ppb)
- Probes NEW physics at the ~ 20 TeV energy scale

Target Scattering Chamber



Large drift pipe



11 GeV
65 μ A
90% pol

All coils for downstream magnet at JLab

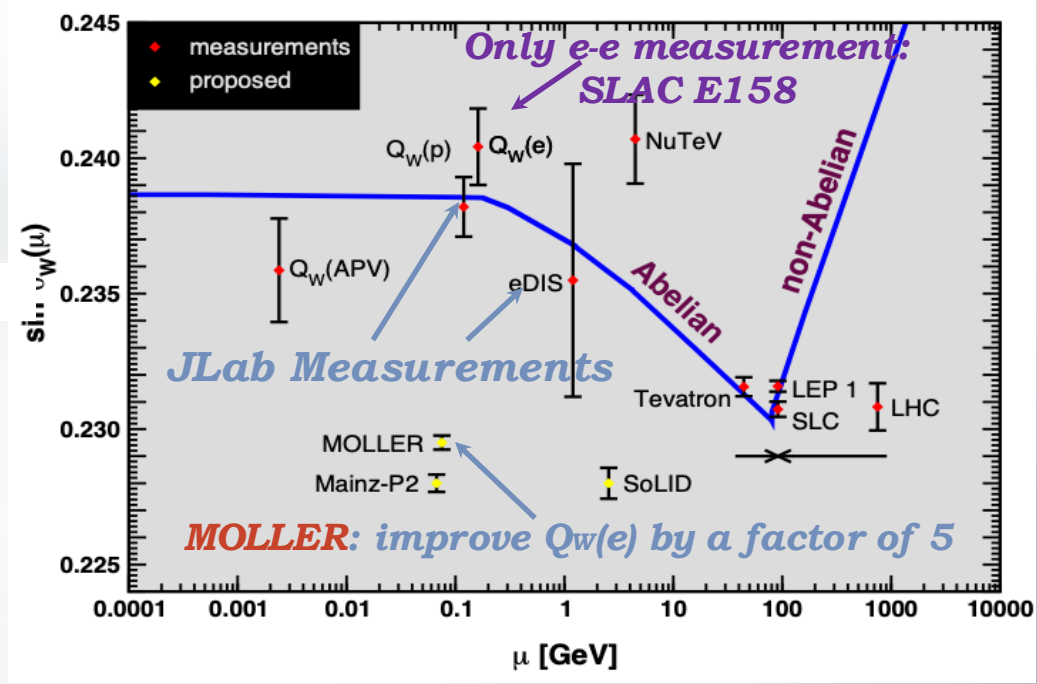

JLab is a recognized leader at the intersection of AI and Nuclear Physics

- This is a HOT topic. We must pursue it or be left behind.
- The good news: a lot is funded already and we have expertise

- Jefferson Lab organized the first **workshop** on "**AI for Nuclear Physics**" in 2020,
 - which led to a **colloquium article** on the topic, currently **cited 138 times**.
- Jefferson Lab staff have since presented on AI applications in Nuclear Physics at various conferences and workshops.
- Staff recently co-led and were members of SC-wide AI/ML application working groups
- **AI is integrated into multiple areas**, including detector control and monitoring, event reconstruction, data analysis, detector design, Lattice QCD simulations, and solving inverse problems in nuclear theory.
- **Notable examples include:**
 - Deep Learning Based Superconducting Radio-Frequency Cavity Fault Classification.
 - AI-Driven Experiment Calibration and Control, demonstrated on drift chambers in GlueX.
 - Hydra: Computer Vision for Data Quality Monitoring, deployed in Halls A–D.
 - CLAS12 Track Reconstruction with AI, enhancing track reconstruction efficiency for CLAS12.
 - Deep Learning for Deep Inelastic Scattering Kinematics, demonstrating AI's potential for physics analysis.
 - Neural-network analysis of Parton Distribution Functions from Ioffe-time pseudodistributions.
 - QuantOm, an AI-driven workflow for imaging quarks and gluons at CEBAF and the EIC, bridging experiment and theory. .

AI Example: Application of HYDRA across HALLS

- Hydra is an AI based system that performs online monitoring.
- Uses the same plots developed for human shift takers to monitor data quality during an experiment.
- Classifies images in near real time and can alert the shift crew of significant problems as they occur.
- User friendly interface via a web browser allows the shift crew and detector experts to monitor experiments from anywhere in the world.



Britton, Jeske, Lawrence, Rajput

Lab wide committee developed an actionable strategy



Laura Biven*



Eric Christy



Markus Diefenthaler*



Tanja Horn



Nobuo Sato



David Lawrence

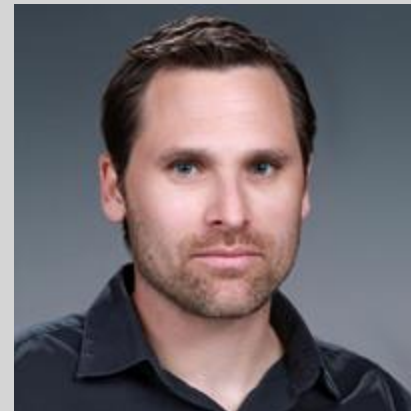

Malachi Schram



Christopher Tennant

Cross cutting team developed a strategy for AI at the Lab

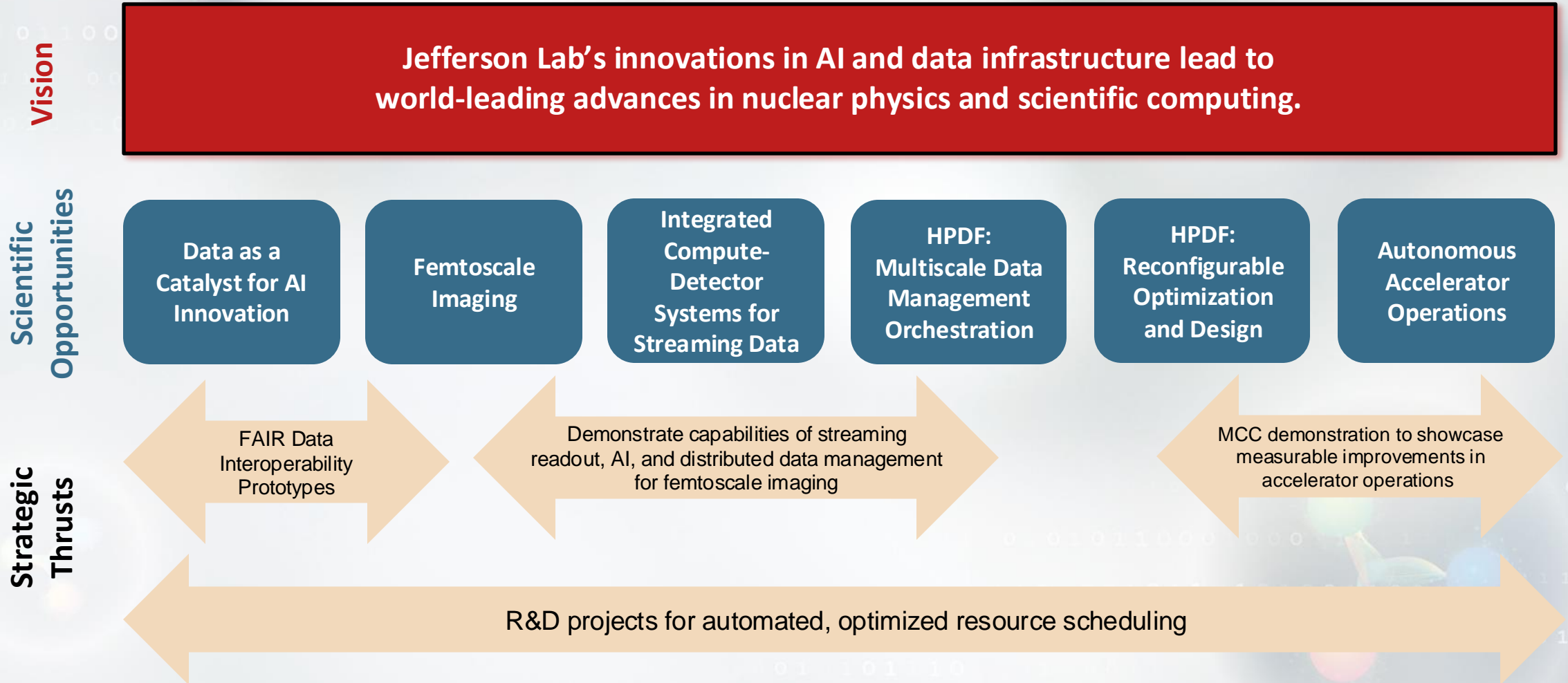

Looking ahead: the next 3-6 months

- The CR will impact operations budgets
 - Realized. DOE recognizes the value of the User Facilities
- What's next and how to get there
 - Reliability of CEBAF – Performance prioritized over energy reach. Develop a 7-year funding profile to execute (underway).
 - EIC partnership -- Develop the early science program; deliver TJNAF CD-3A scope
 - SoLID (~\$100M MIE) – Shovel ready; continue R&D to reduce risk
 - HPDF and JLDC – Progress to CD-1 and JLDC design/build
 - Pursue AI Strategy implementation (part of LDRD Call)



Discussion