SpinQuest Polarized Target System

Vibodha Bandara , Dustin Keller



U.S. DEPARTMENT OF
ENERGY

Office of
Science

Outline

- Overview of the target setup
- Key components of the SpinQuest target setup
 - Super conducting magnet
 - Target insert
 - Evaporation refrigerator
 - Microwave system
 - NMR system
- Further developments
- Summary

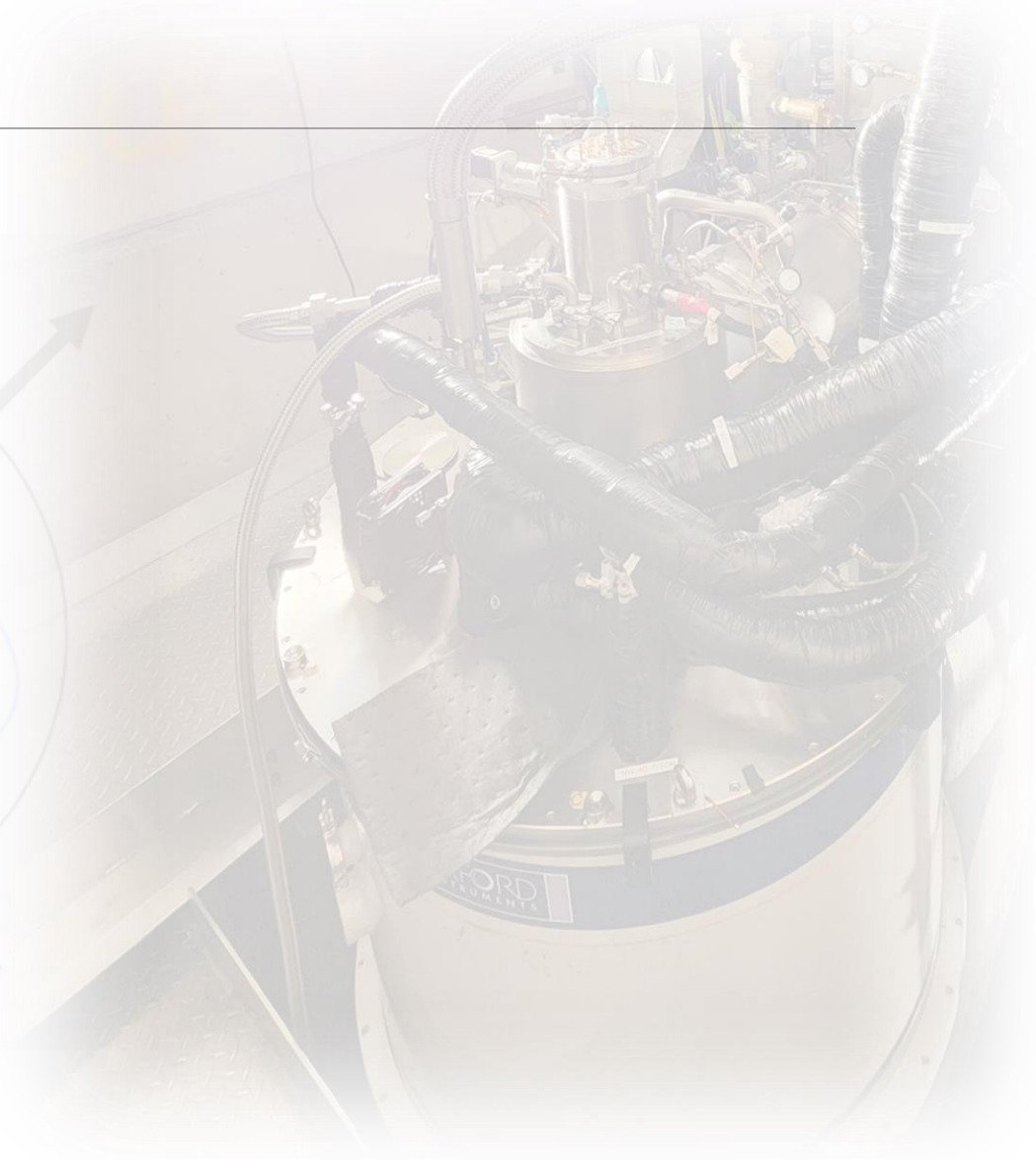

Overview of the target system

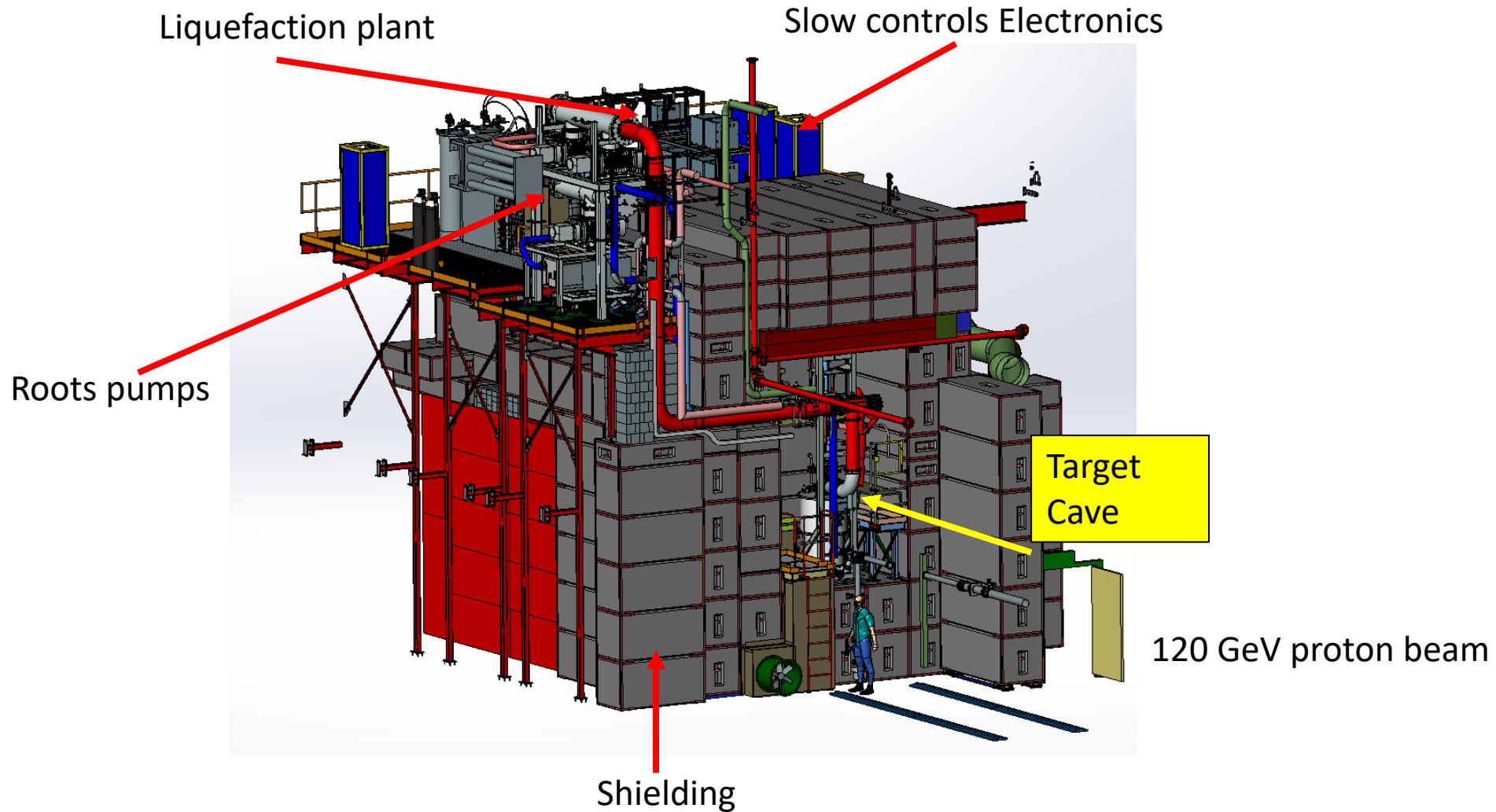

Overview of the target system



Overview of the target system

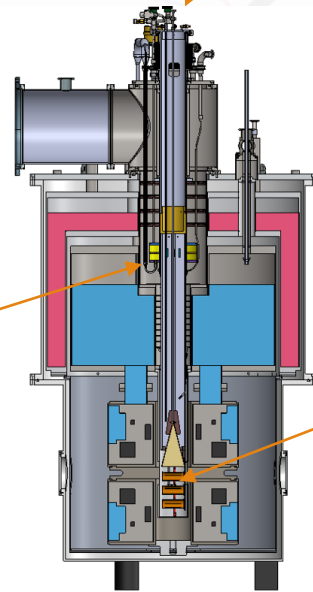
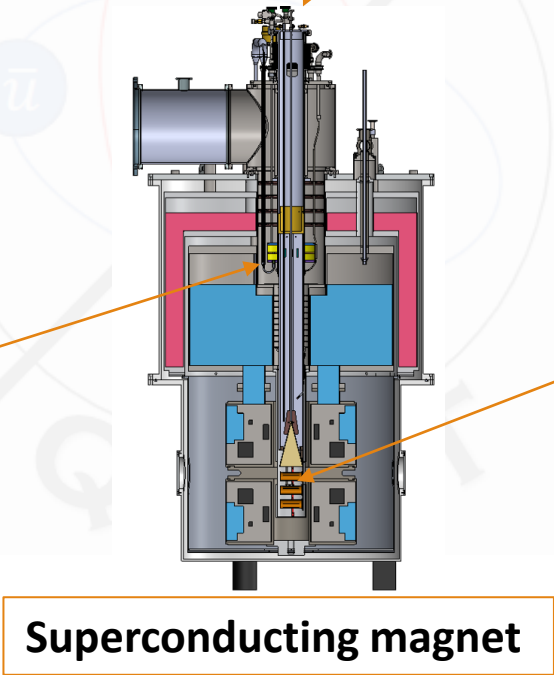
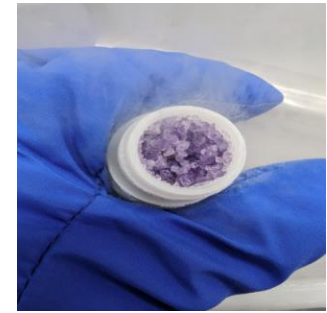
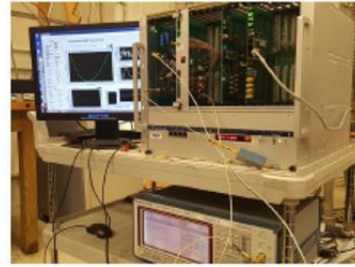
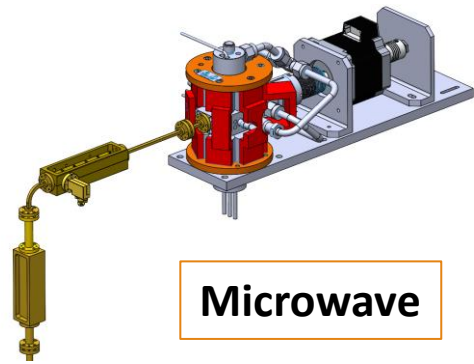

The super conducting magnet

- Horizontal field 5T split pair magnet
- Liquid Nitrogen shielded, vacuum insulated cryostat
- The nitrogen shield minimize the heat load into the helm space
- The 150 liters liquid helium dewar
- The helium dewar has 5 psig operational relief and 12 psig rupture disk as a safety relief
- The magnet is powered by MercuryIPS from Oxford instruments
- During the production runs, the magnet coils were ramped up to 74.47 A and kept in the persistence mode

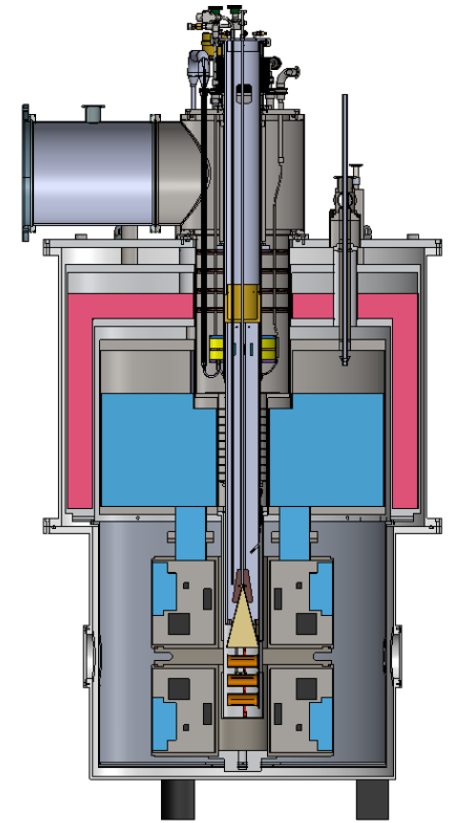

Target insert and positioning

Target insert

- The target insert contains three 8 cm long target cells made out from Kel-F material
- Each cell contains three NMR loops and three chip resistors
- Cernox sensors are attached to the top and bottom cups to determine the temperature of the target materials
- The body of the target insert made from carbon fiber to minimize the thermal conductivity

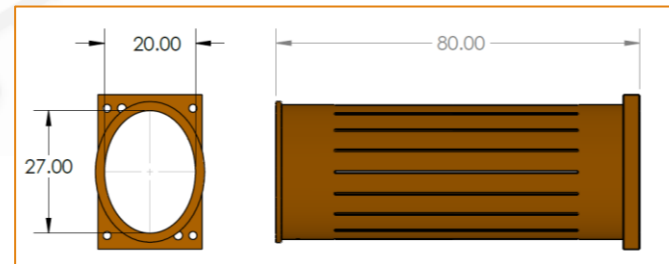
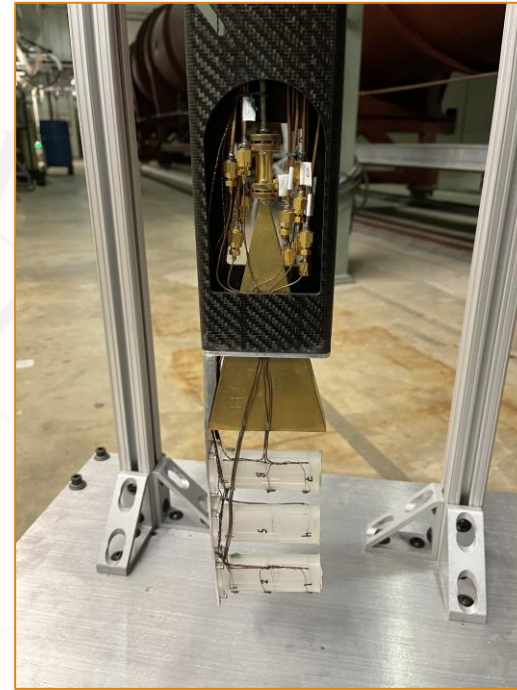

Target insert and positioning

Target lifter system

- The target lifter setup positions each target cell between the beam line and the annealing plates
- The resolution of the target lifter is 0.005 mm
- Stepper motor : 200 steps/ rev
- Two string potentiometers gives the absolute position

Kenichi will talk about the beam alignment studies

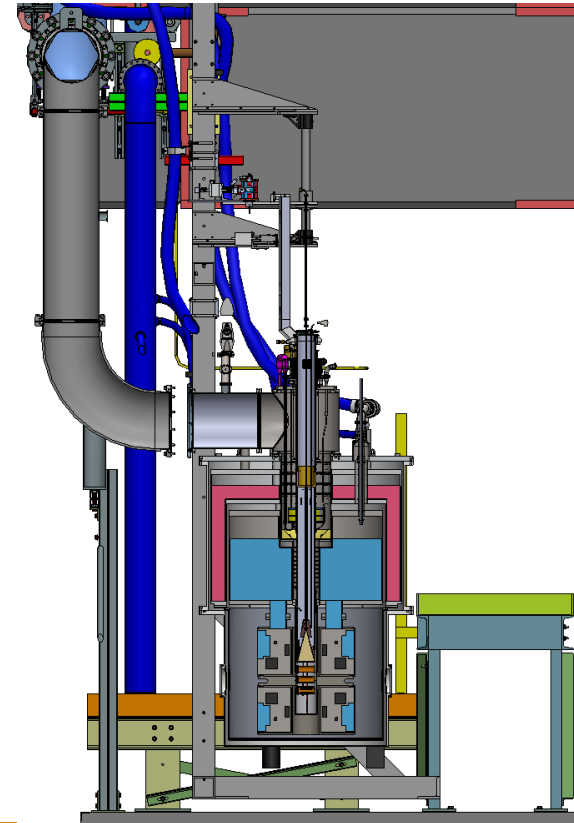
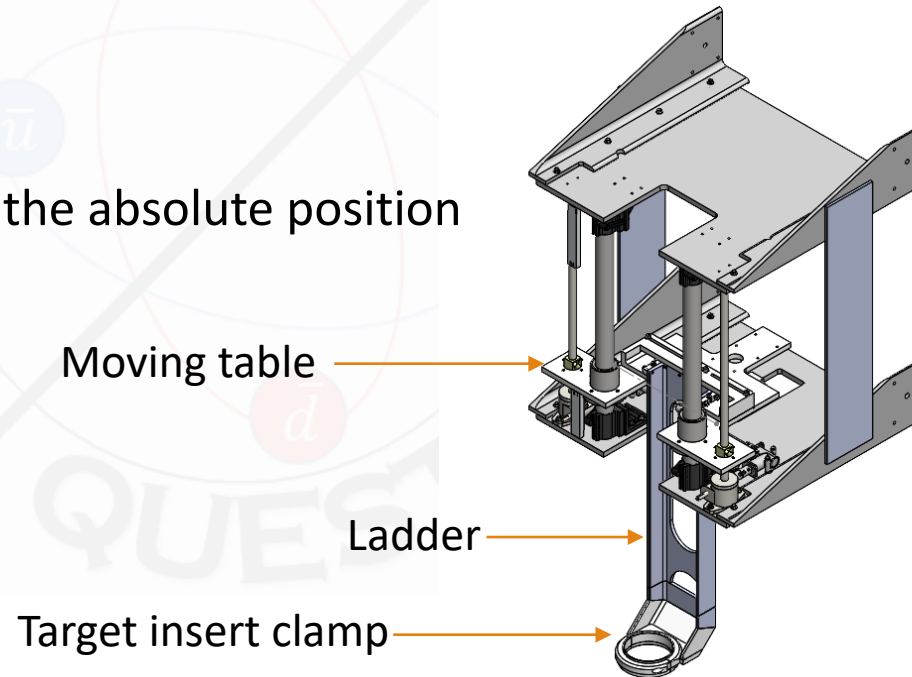

Target insert and positioning

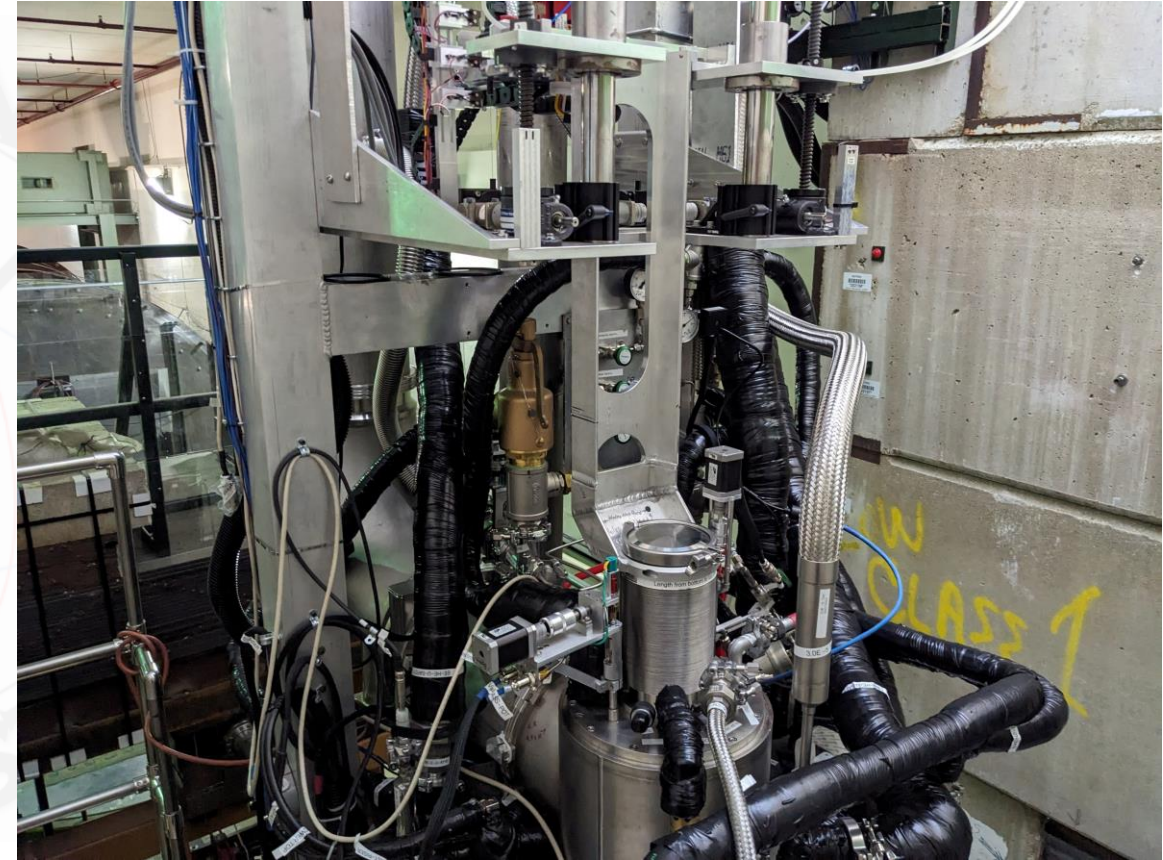

The refrigerator system

- The He4 evaporation refrigerator provides the required cooling power for the target materials during the beam interaction and the dynamic nuclear polarization (DNP)
- The refrigerator was built to meet ASME (American Society of Mechanical Engineers) specifications

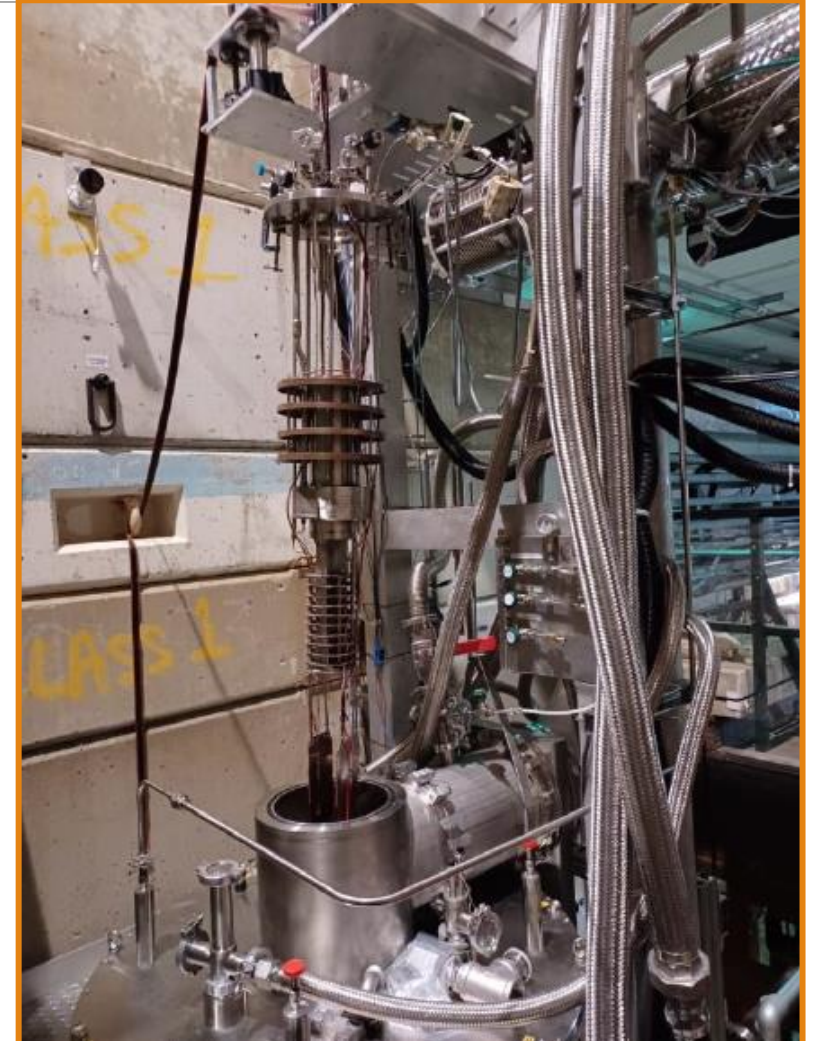

The refrigerator system

- The liquid in the separator has two paths to reach the nose reservoir whereas the target materials are located located
 1. Run valve path
Liquid passes around the heat exchanger
 2. Bypass valve path
Liquid bypasses the heat exchanger and reach the nose
- Run valve and the bypass valve controls the liquid level in the nose. However, during the production (Polarizing) only the run-valve in operation

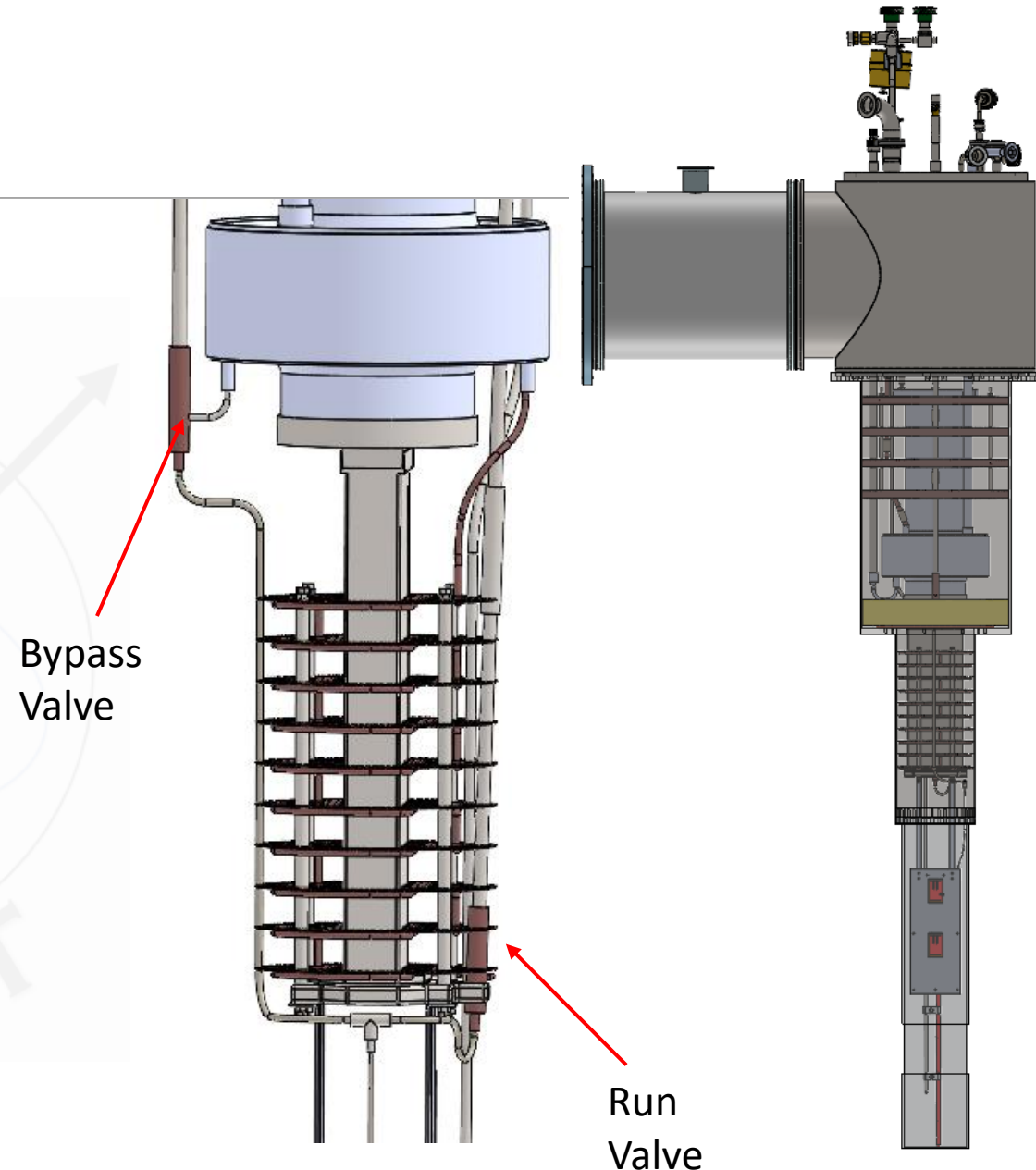

The refrigerator system

- The run and bypass valves are controlled by two custom made motorized actuators

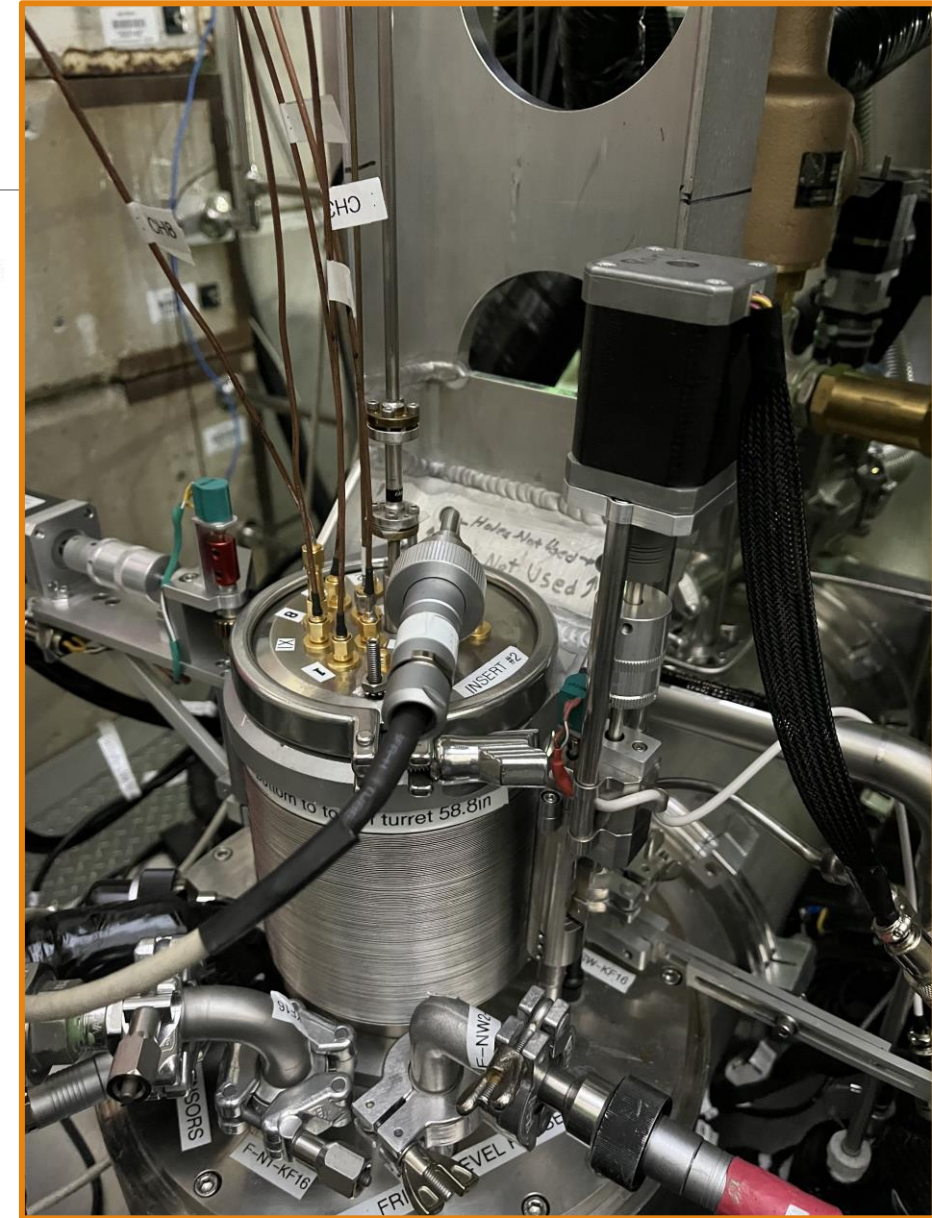
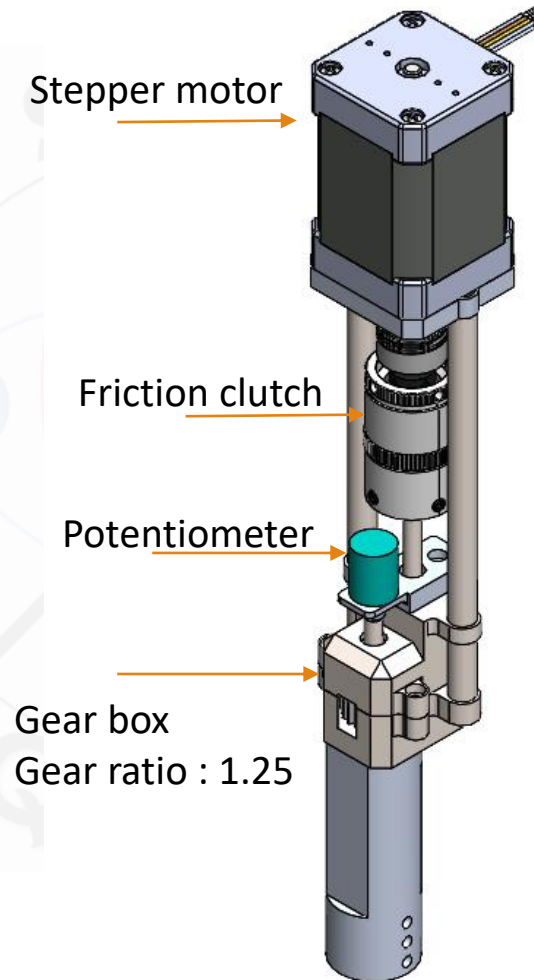

The refrigerator system

- The high capacity (17000 m³/h) roots stack is extremely effective during the polarization to bring the target materials down to 1K .
- However, this pumping speed is too high for TE measurements. Even the smallest pump, rotary vane pump 840 m³/h is too large for thermal equilibrium state
- The pumping speed can be regulated by changing the motor frequency of the pumps. However, we do not have this feature due to safety policies in the Fermilab
- We converted an existing manual valve to a radiation hard flow controller by adding a motorized actuator.

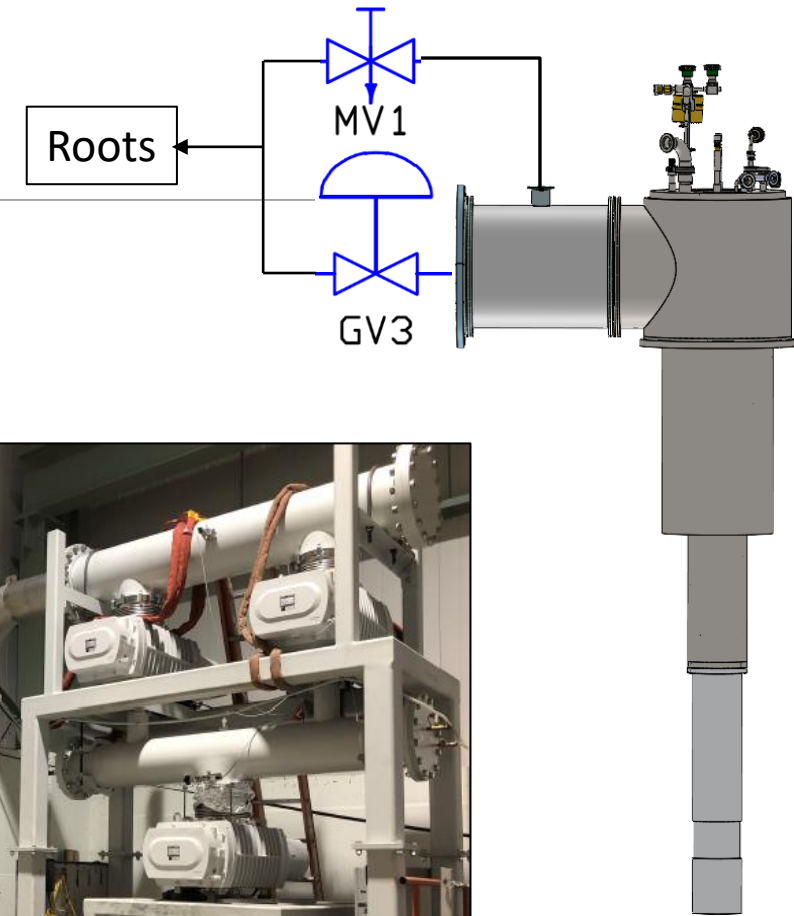

The refrigerator system

- The new flow controller valve operates in a PID loop to maintain a stable helium vapor pressure.
- Successfully achieved TE measurements at 1.5 – 3K
- The design of this valve was presented in the SPIN 2023 conference

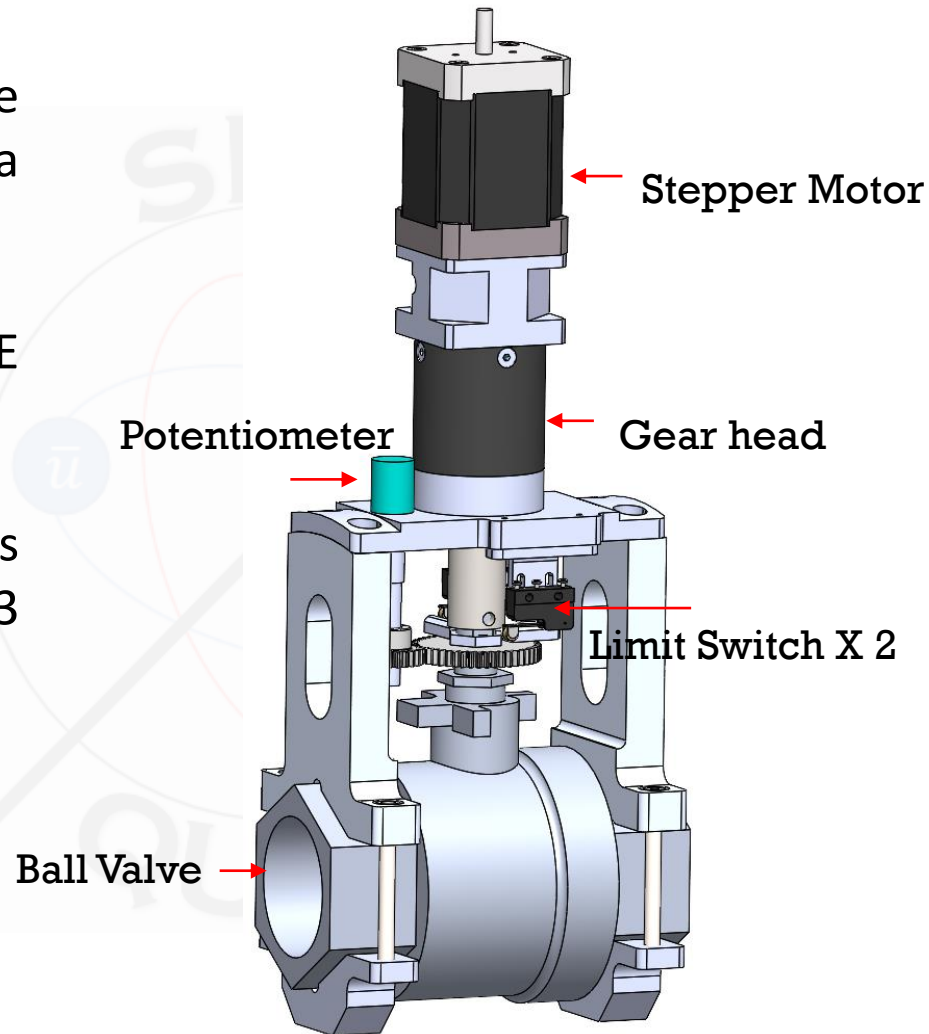

■ TE plots at 2K

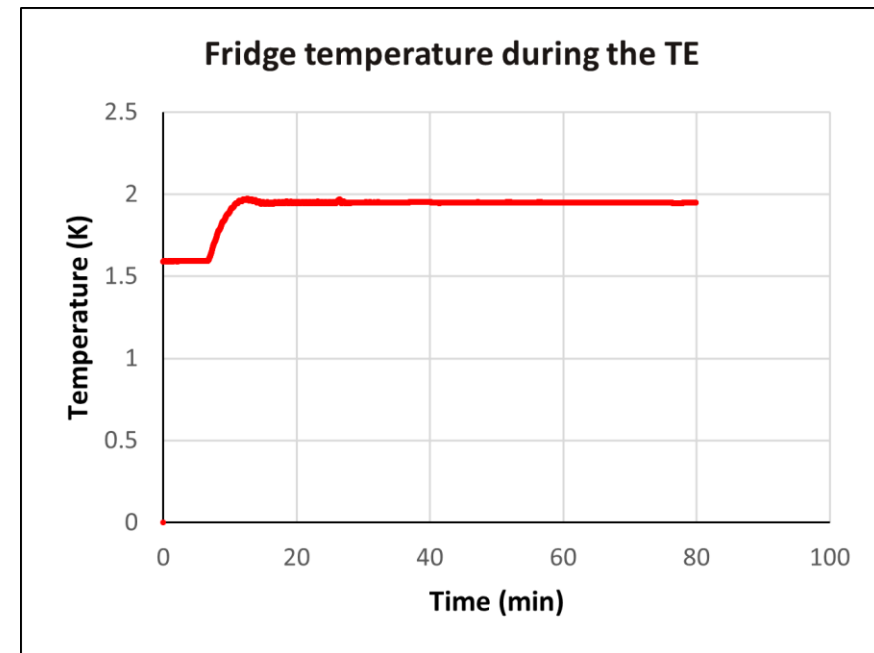
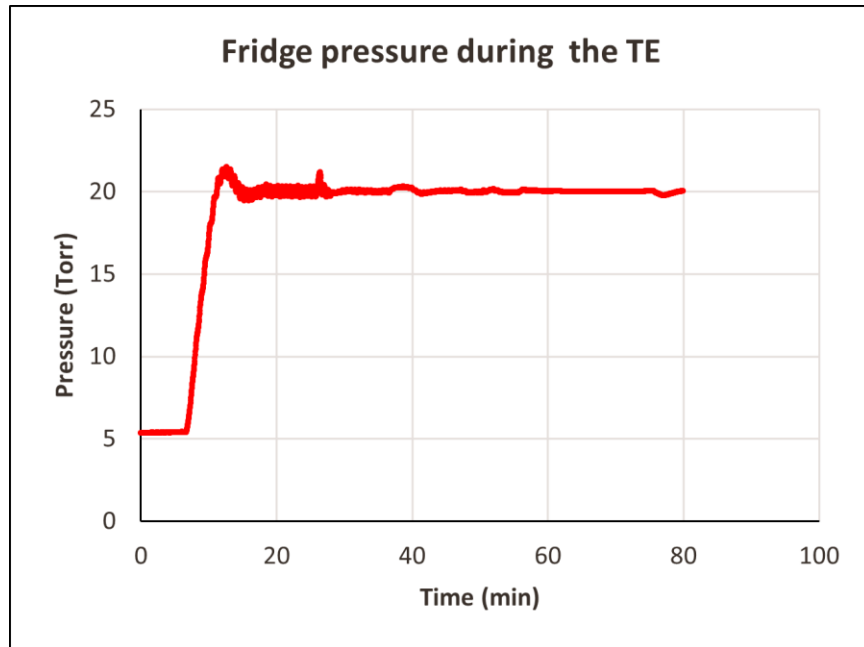

This successful TE measurement indicates

- The mechanics, electronics, and the control program of the new valves are synchronized and successful

The Microwave system

Microwave System

- The RF signal needed for the Dynamic nuclear polarization (DNP) is provided by an Extended interaction Oscillator (EIO)
- The output frequency is fine tuned by the changing the size of the resonant cavity inside the EIO.
- The EIO is coupled to a stepper motor. 1 step \rightarrow 0.001 GHz when operating in full step configuration

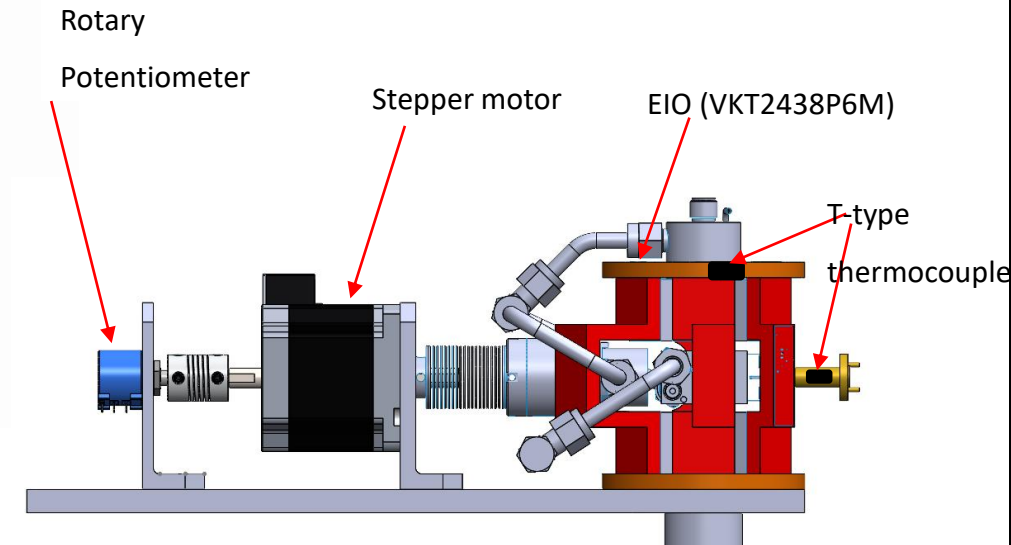
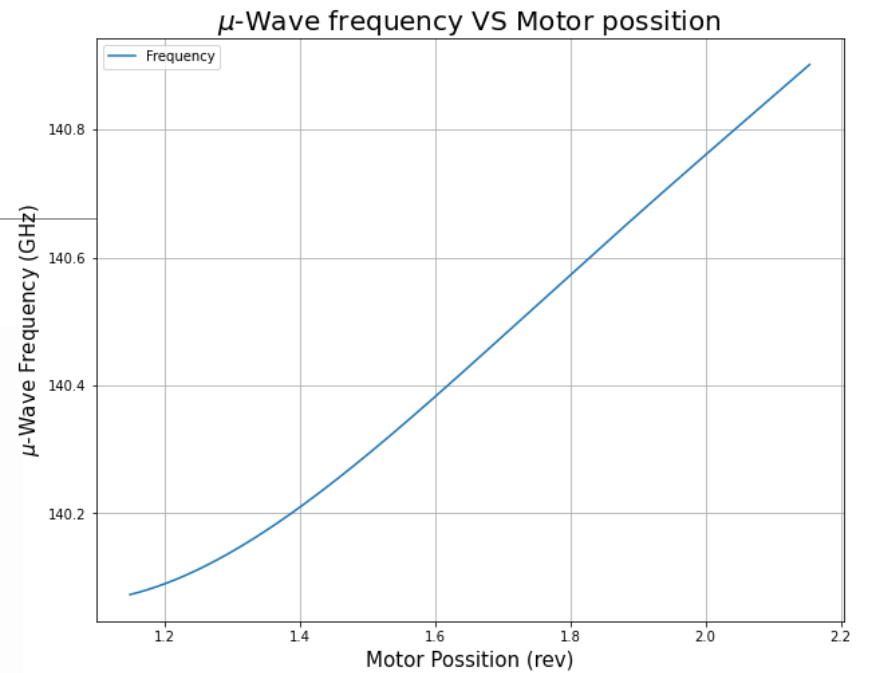

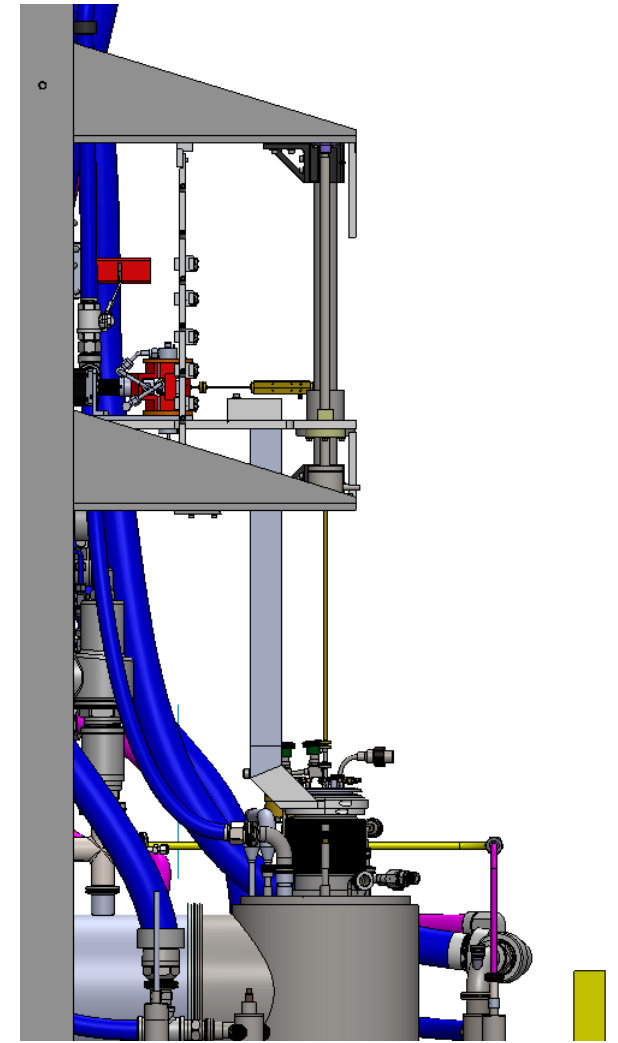
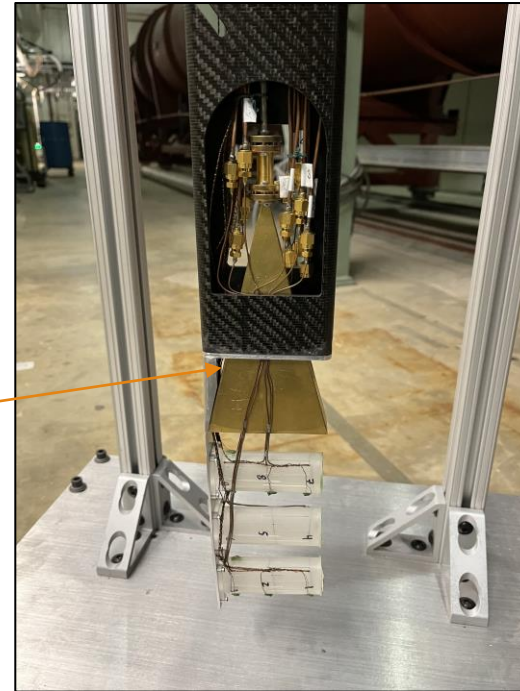
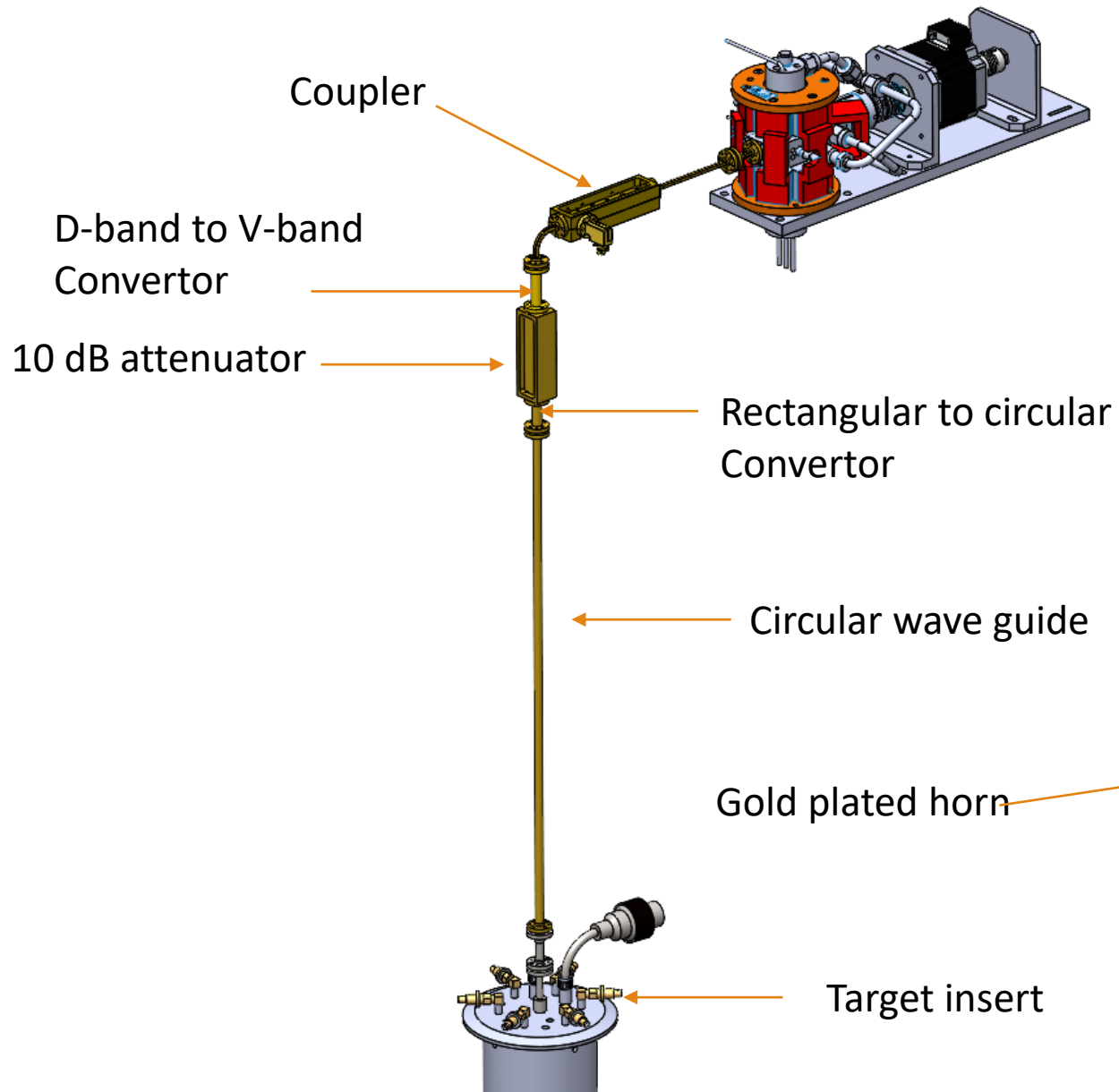

The Microwave system

Polarization results during the commissioning

- During the commissioning period the target insert was loaded with NH₃
- The maximum positive polarization was 96% it took around 40 mins to reach the maximum
- Negative polarization level was 85% and it took around 80 mins to reach the maximum
- The optimum frequency for the GHz and the positive frequency was 140.14 GHz Negative polarization was 140.43
- The maximum microwave 1.2 Watts

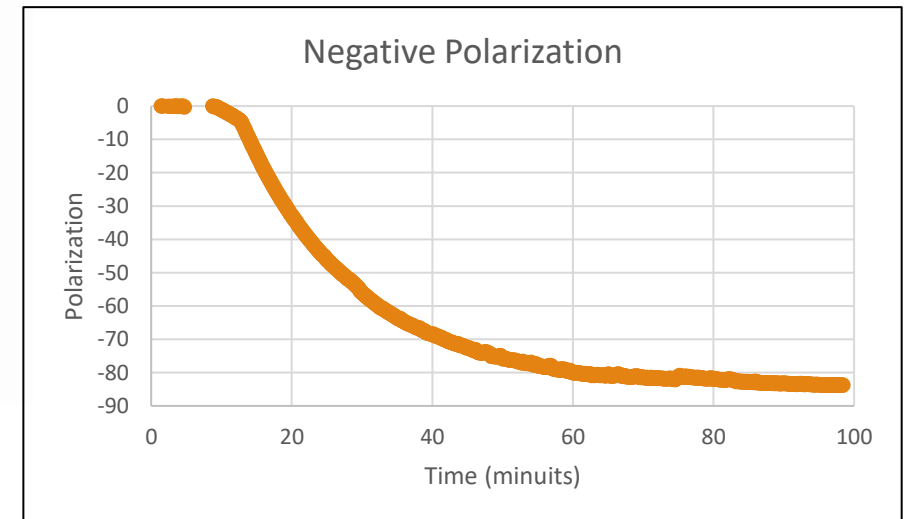
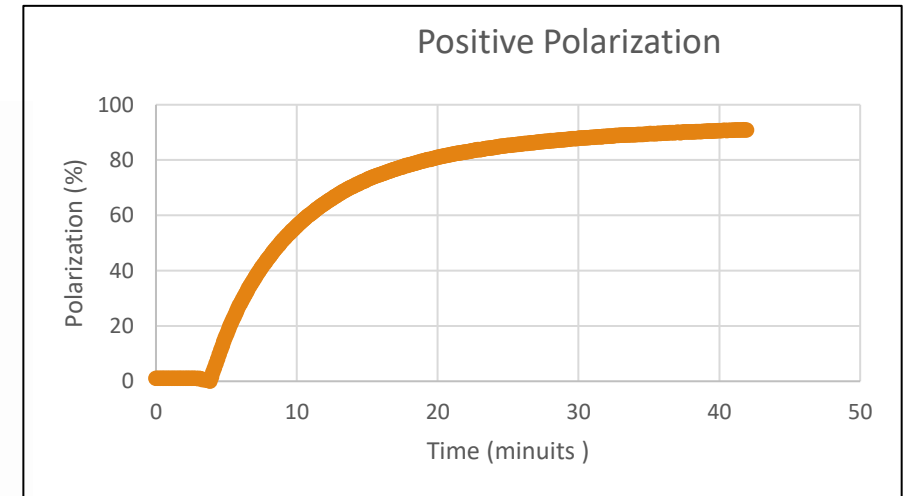

NMR system

- **UVA standard Liverpool based Q-meter NMR**

consists of three Q-meters, can switch over three NMR coils

- **UVA AI based Qmeter NMR :**

An AI program will determine the area under the Q-curve. The hardware is same and the standard NMR. but we are working on hardware (RF electronics) improvements to better integrate the AI.

More information : Devin's talk , Tomorrow

- **UVA Cold NMR system:**

The tuning circuit will be located with the target material. Ideally zero length between the NMR coil and the tuner

- **LNAL VME based NMR system**

The LNAL NMR system contains the standard NMR and cold NMR versions. The standard NMR is ready to use.

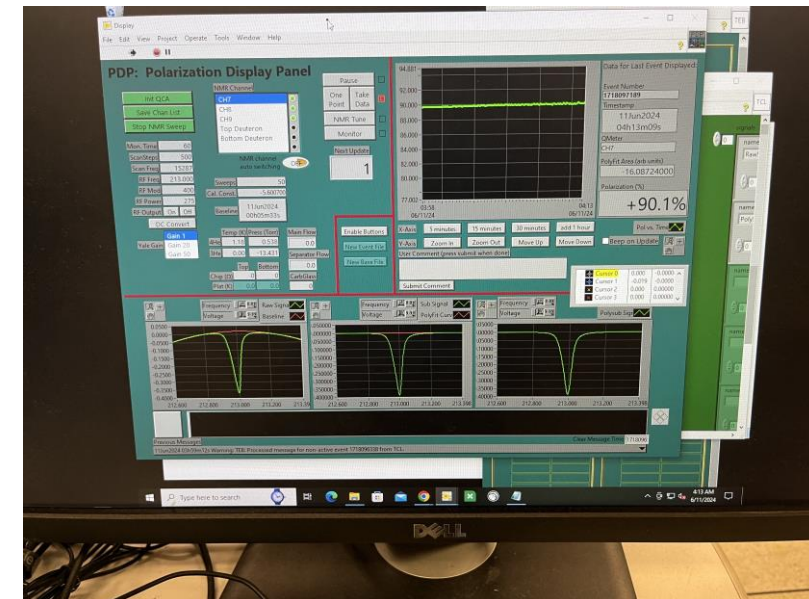
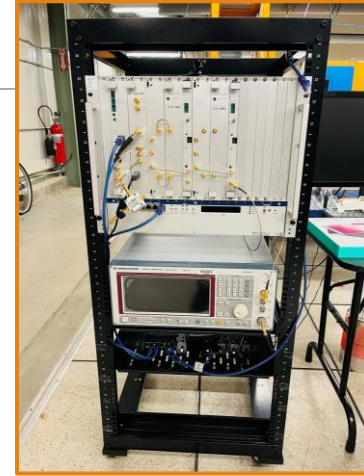

The Liquid helium supply

- Two liquefiers from Quantum Technologies.
- Each liquefier contains five cold heads
- Two 200L liquid helium storage tanks
- Produce 200 Liters/day and consumes 100L/day during nominal production running

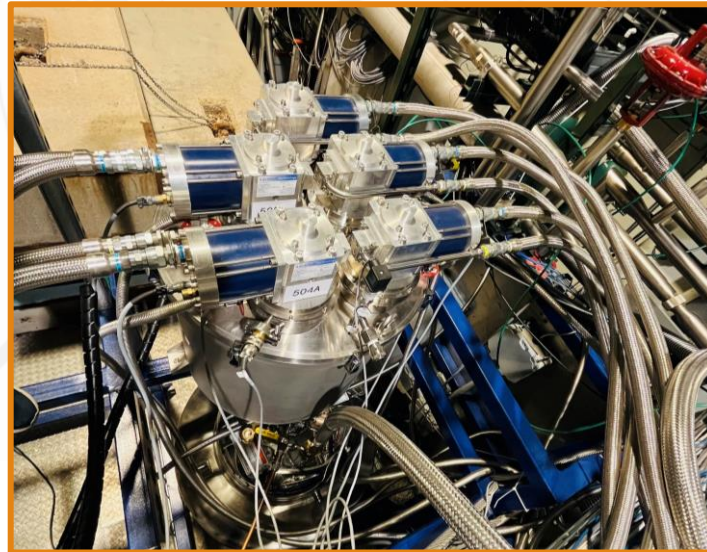

Further developments

A variable microwave attenuator will be added to control the microwave power to the target cells. The microwave power will be controlled remotely 0-1.2 W.

Modulate the microwave frequency to improve the overall target cell polarization
The cathode voltage of the power supply will be modulated through the RS485 communication interface.

The cathode voltage can be adjusted in steps of 1 V.

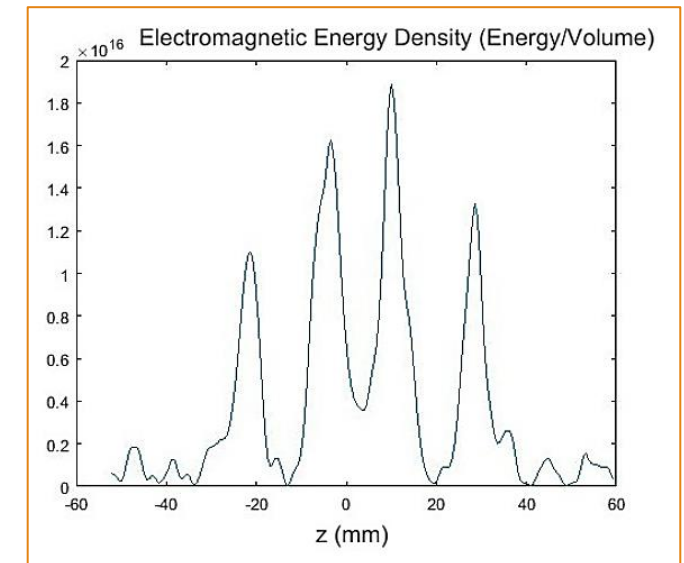

Further developments

Annealing system

Currently we have a manual control annealing system and we have done successful annealing during the commissioning period.

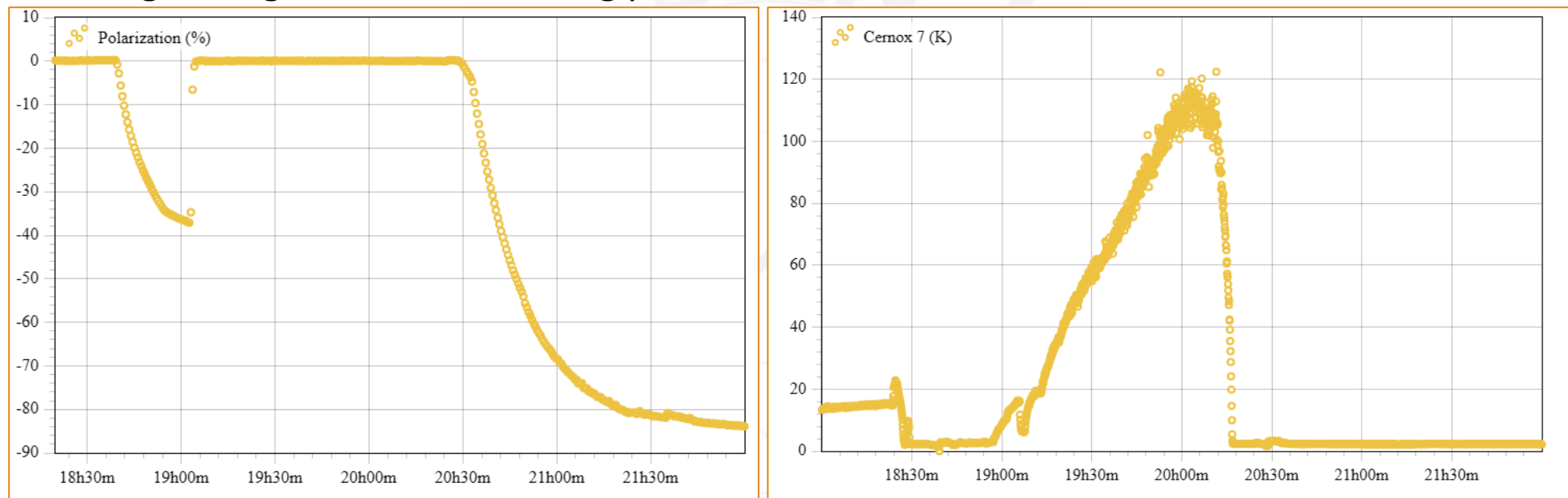

The annealing system will be updated with a computer controlled system which enables the automate the annealing process

Summary

- We designed the cryosystem functionality and FNAL ensures all safety aspects of engineering
- The first beam commissioning of the SpinQuest was successful. All the sub systems operated as expected.
- The target system is built for high radiation environment. All the systems in the target cave was designed to survive high radiation
- The cooling power of the fridge was calculated as 5W at 1.1K
- The maximum online positive polarization was (NH3) 96% and negative polarization was 85%
- Achieved CH2 polarization : 26.4%
- The custom-made valves on the refrigerator system worked as expected.

Thank You



U.S. DEPARTMENT OF
ENERGY

Office of
Science

This work was supported by the U.S. Department of Energy (DOE) Contract No. DE-FG02-96ER40950