

# Recent Activities Report from Hall B

Richard Capobianco

University of Connecticut

Presentation for the JLUO Satellite Meeting

# Experiments by Run Group C

**Hall B Run Group C (RG-C) was scheduled to run from June 8, 2022, to March 20, 2023**

- The objective of the group is to measure the spin structure of protons and neutrons utilizing polarized electrons and a longitudinally polarized target
- Used polarized 2.2 GeV and 10.5 GeV electron beams on polarized  $\text{NH}_3$  and  $\text{ND}_3$  targets (as well as several auxiliary targets)

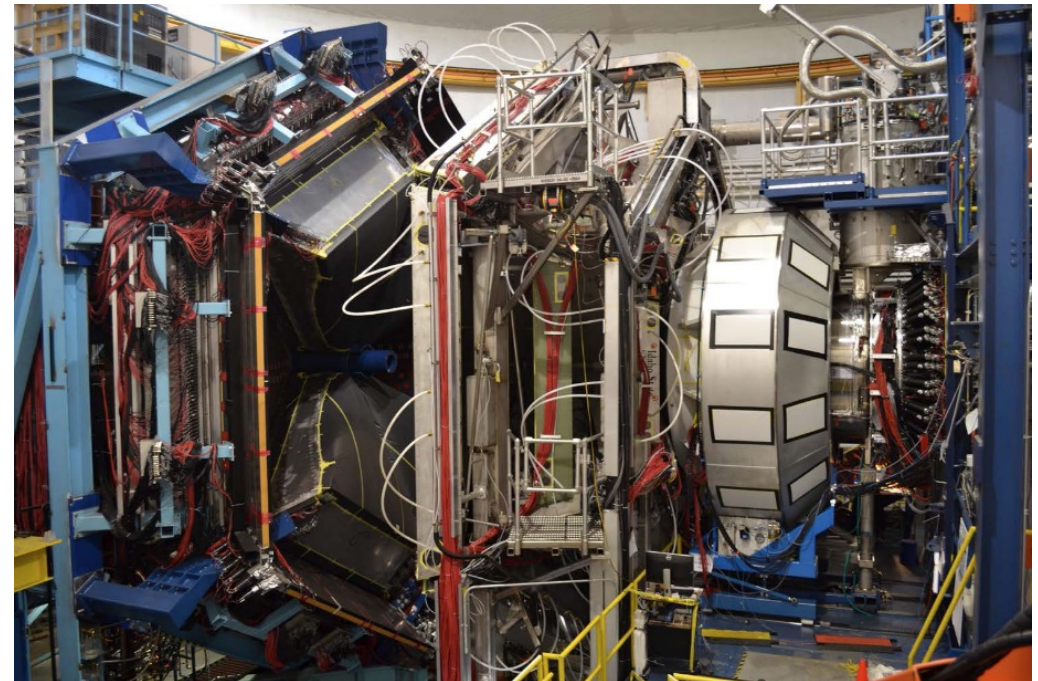

[V.D. Burkert, L. Elouadrhiri, et al., Nuclear Inst. and Methods in Physics Research, A 959 (2020) 163419]

# Experiments by Run Group C

## The experiments were divided into four distinct parts:

- Started with the commissioning at 2.2 GeV (4 days)
  - Measured beam/target polarization, spin structure functions at low  $Q^2$ , and commissioned raster/target operations
- Ran the 10.5 GeV beam with standard “FTOn” config. from Jun 13 - Aug 31
  - Ran for 69 days (35 PAC days but, due to lower efficiencies than expected, only 28 PAC days of real data)
- After ~1 week of config. change, began running “FTOut” part of RG-C with new bespoke Möller cone
  - Duration shortened to 70 days (35 PAC days but was effectively 25.4 PAC days due to lower efficiency) from the originally planned 107 days (53 PAC days) due to solenoid magnet power supply failure on Nov 11.
  - The Möller cone can accommodate 9 mm raster on 2 cm diameter, 5 cm long target cell with 10 nA beam for a luminosity of  $1.2 \times 10^{35}$  nucleons/cm<sup>2</sup> electrons/sec (replaced the Forward Tagger)
- Starting Jan 30, 2023, reverted to “FTOn” config. for the remaining runtime

# Hall B Setup: Polarized Target and Faster Changes

## Longitudinally polarized cryo-target inside solenoid

< ~80% H polarization

< ~45% D polarization

- Dynamic Nuclear Polarization done by 140 GHz  $\mu$ waves
- 1 K with  $\ell$ He refrigerator

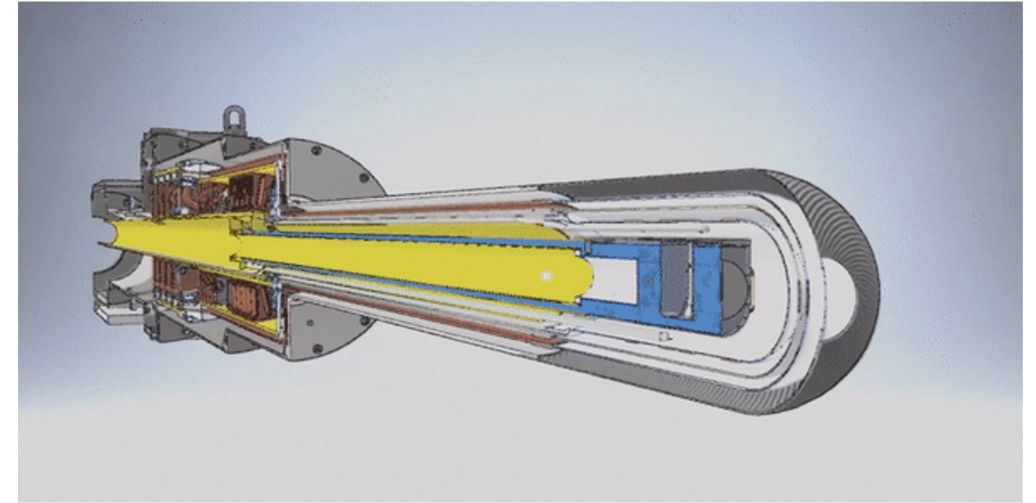

<https://youtu.be/22PTbdC2sjw>

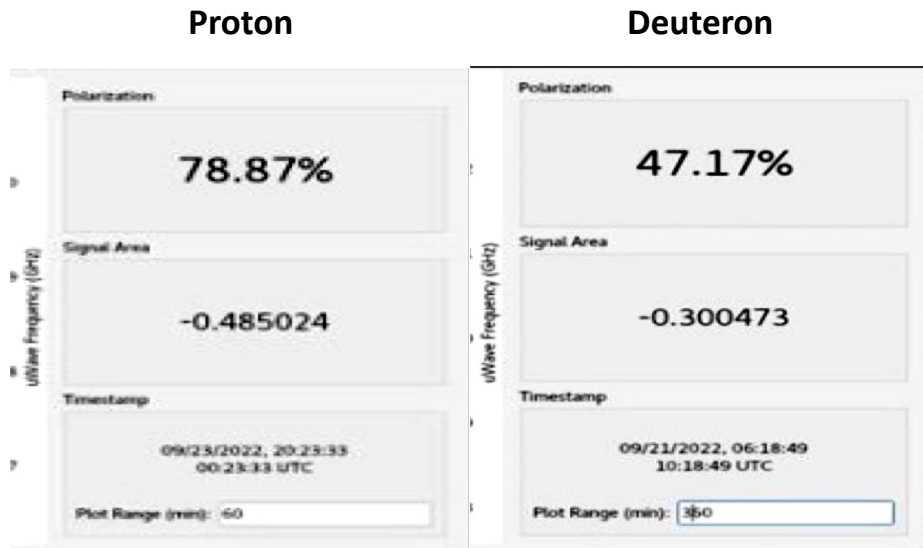

- Novel solution for Fast Target Changes was developed (i.e., the Mobile 1 K Bath - a.k.a. the Trolley)
- This method saved a minimum of ~18.75 days of downtime over the traditional method of swapping targets (see video above – Provided by James Brock)

# Solenoid Power Supply Failure

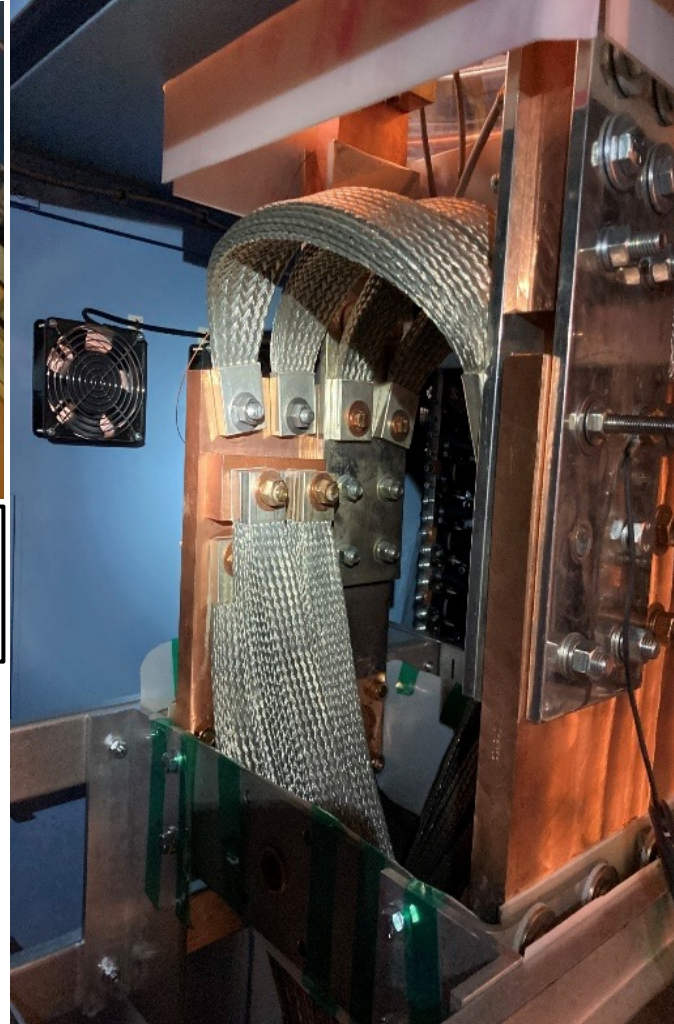
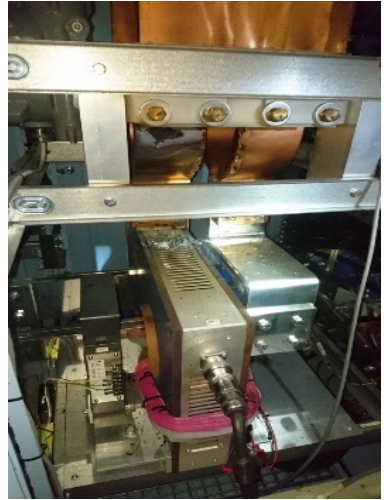

Team from  
Danfysik, DC Power,  
Hall B, DSG

- **Power Supply Failure Occurred on 11/11/2022**
- Polarity reversal at  $> 1000$  A caused melted copper links and contacts
- Hall B was down for 80 days during current RG-C run
- Approved physics program could not get completed before SAD 2023

**Repair completed  
(1/30/23)**

\*These images were collected by Patrick Achenbach

# RG-C Data Taking 2022–2023

**1<sup>st</sup> period:  
June–Aug 2022**

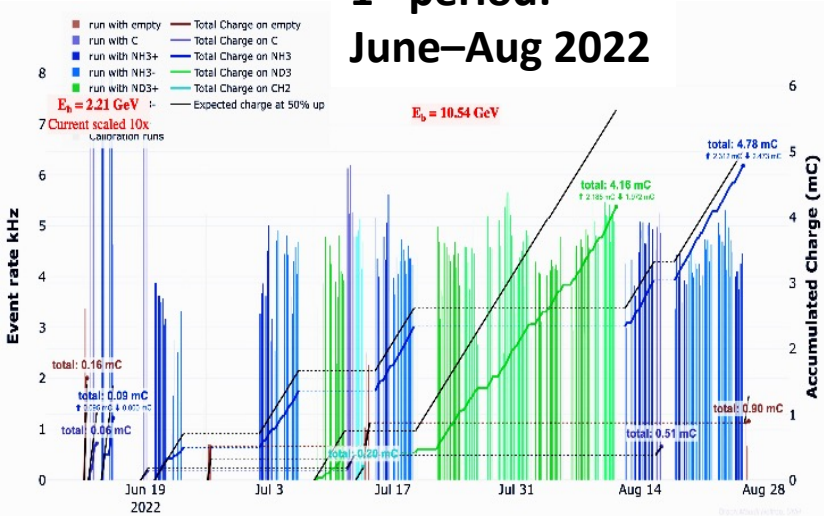

**2<sup>nd</sup> period:  
Aug–Nov 2022**

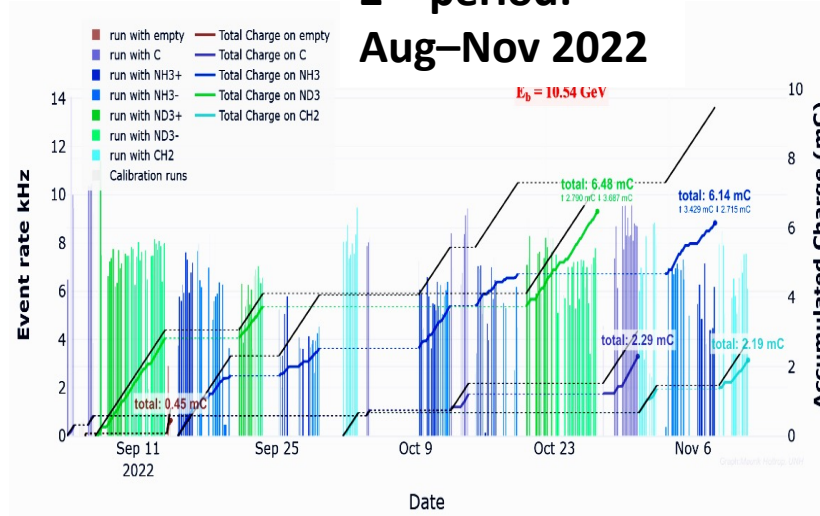

**3<sup>rd</sup> period:  
Feb–Mar 2023**

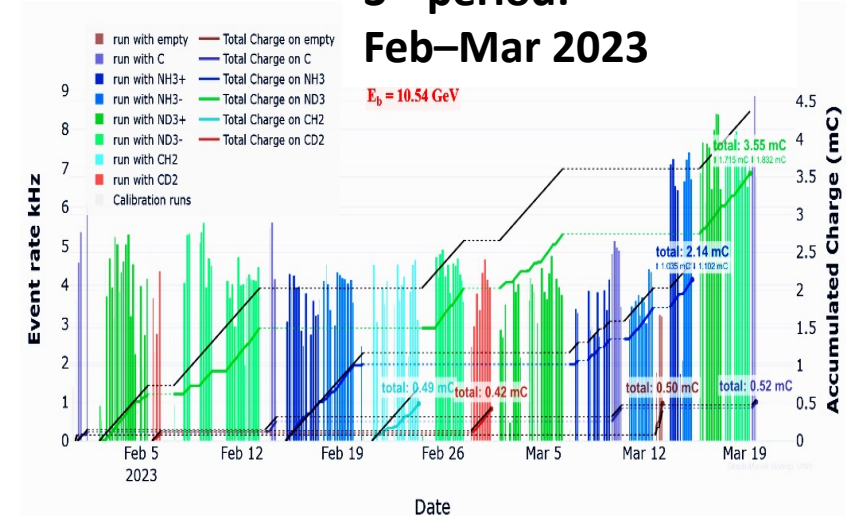

- Calibration (dilution factor, background subtraction, alignment): C, CH<sub>2</sub>, CD<sub>2</sub>, empty, zero-field
- Missing Run Period between Nov. and Feb. due to Solenoid Failure
- Online trigger-bit polarization reconstruction follows relative NMR reading closely
- At start of 3<sup>rd</sup> period: Highest degree of polarization in ND<sub>3</sub> ever observed by the target experts

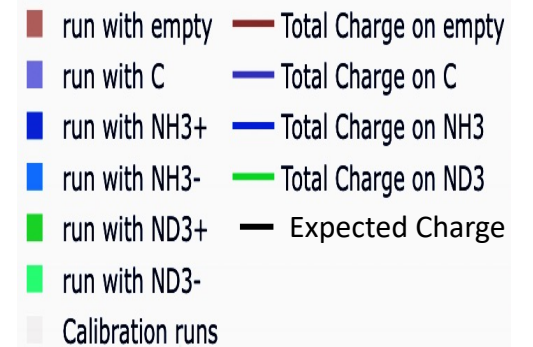

# RG-C Data Taking 2022–2023 (Total Events)

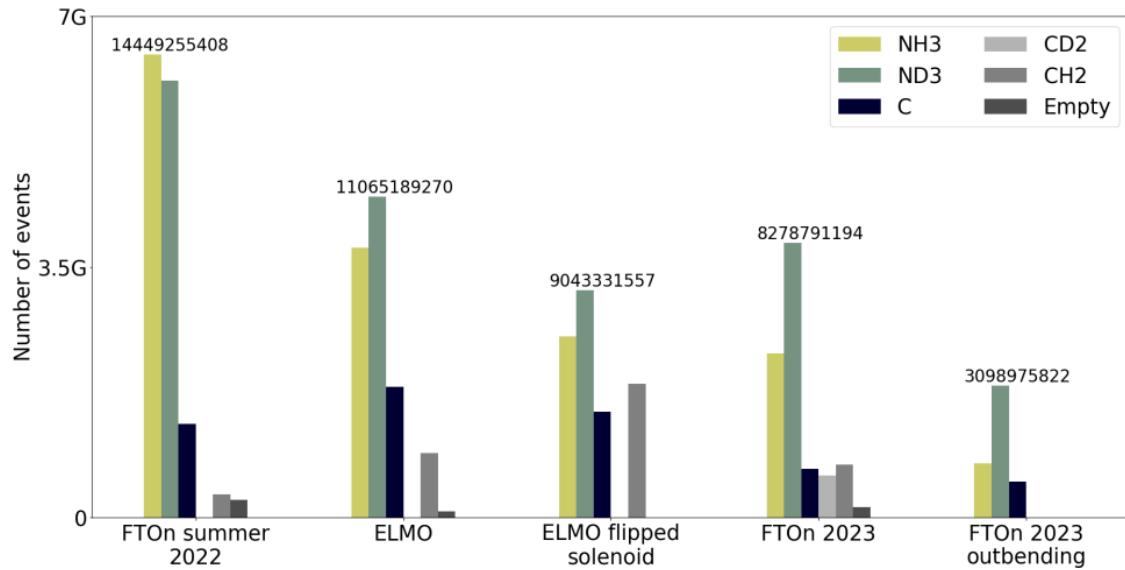

- FTO on 2022 : 14G events.
- ELMO : 20G events.
- FTO on 2023 : 8G + 3G events (inbending/outbending torus).

- Calibration (dilution factor, background subtraction, alignment): C, CH<sub>2</sub>, CD<sub>2</sub>, empty, zero-field
- Missing Run Period between Nov. and Feb. due to Solenoid Failure
- Online trigger-bit polarization reconstruction follows relative NMR reading closely
- At start of 3<sup>rd</sup> period: Highest degree of polarization in ND<sub>3</sub> ever observed by the target experts
- **RG-C has ended as of March 20, 2023**

# Preliminary Run Group Scheduling in Hall B

Preliminary Hall B Run Groups and Schedule

2023-2026								Scheduled PAC days = cal. days/2	Remaining PAC days after end date
START DATE	END DATE	Calendar Days	Remaining PAC Days	Setup/Exp.	Target	Beam Energy	Run Group		
2022-06-14	2022-11-11	143	120		long. polarized NH3/ND3	11	RG-C	71,5	49
2022-11-12	2022-12-19	37		downtime					
2022-12-20	2023-01-12	23							
Winter break									
2023-01-21	2023-01-29	8		downtime					
2023-01-30	2023-03-19	48	49		long. polarized NH3/ND3	11	RG-C	24	25
2023-03-20	2023-07-20	122		setup change	target change			SAD 2023	
2023-07-21	2023-09-17	58	30		liq. D2 & nucl. (JLab)	11	RG-D	29	1
2023-09-18	2023-09-22	4			target change				
2023-09-23	2023-12-17	85	88		liq. H2	6,6	RG-K	42,5	45,5
2023-12-18	2024-01-10	23			target change				
Winter break									
2024-01-15	2024-03-17	62	60		liq. D2 & nucl. (Chile)	11	RG-E	31	29
2024-03-18	2024-07-18	122		setup change	target change			SAD 2024	
2024-07-29	2024-11-12	106	55	ALERT	high pressure gas	11	RG-L	53	2
2024-11-12	2024-11-16	4			target change				
2024-11-20	2024-12-15	25	46		liq. H2	8,8	RG-K	13	33
2024-12-16	2025-01-12	27							
Winter break									
2025-01-13	2025-03-17	63	33		liq. H2	8,8	RG-K	32	2
2025-03-18	2025-07-23	127		setup change	target change			SAD 2025	

- 2023 SAD for installation of cryo-target and solids
- RG-D: Jul to Sept 2023, ~30 PAC days to **complete****
- RG-K: Sept to Dec 2023, to reach ~50% PAC days
- RG-E: Jan to Mar 2024, to reach ~ 50% PAC days
- 2024 SAD for installation of ALERT
- RG-L: Jul to Nov 2024, ~55 PAC days to **complete****
- RG-K: Nov to Mar 2025, ~45 PAC days to **complete****
- 2025 SAD for setup/target change

## Remaining PAC days for run groups

- RG-A: >70 PAC days
- RG-B: +/- 40 PAC days
- RG-C: +/- 25 PAC days
- RG-E: 30 PAC days
- RG-M: 10 PAC days

## Not scheduled

- Non-CLAS12 experiments: PRad-II,  $\pi^0$ TFF, X17
- CLAS12 experiments: Polarized He-3, H-3 and He-3, transv. polarized H/D, long. polarized LiH/LiD

- SAD 2023: With more gradient (overhead) but same energy should mean a stable machine
- Mid-2025 is a time non-standard beam energy experiments



# Next Run Group Scheduled in Hall B: RG-D

Hall B Run Group D (RG-D) is scheduled to begin running starting in July

**RG-D consists of two experiments:**

- [Study of Color Transparency \(CT\) in Exclusive Vector Meson Electroproduction off Nuclei](#)
  - Aims to extend the investigation of CT phenomenon in the meson sector at higher energy and momentum transfer
  - Expected to produce smaller configurations that live longer, expand slower, and exit medium intact (primary pillars for CT studies)
- [Nuclear TMDs in CLAS12](#)
  - Aims to decipher the effect of in-medium modifications of the transverse momentum distributions (TMDs) in nuclei

Development of unpolarized cryo target

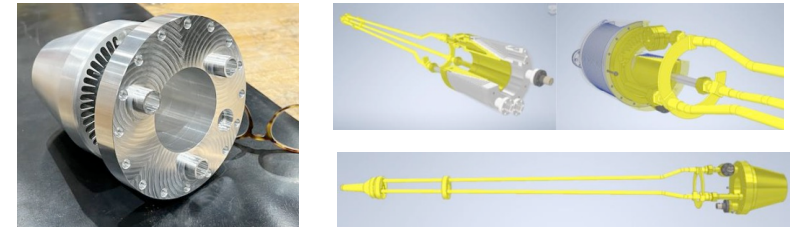

Refurbishment of non-maintained Saclay target

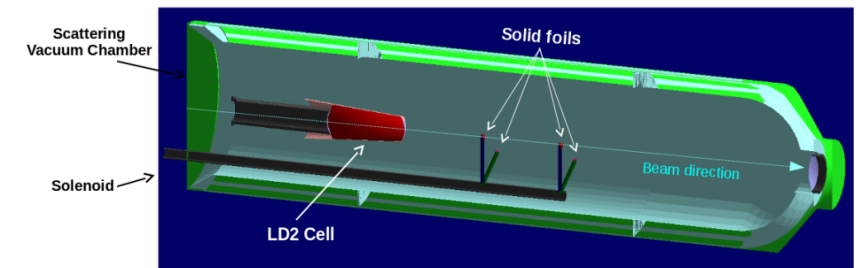

# Hall B – Planned Upgrades/Developments

## 1. Beam Dump (Phase 1) Upgrade:

- No need for beam blocker anymore due to new safety evaluation
- Faraday cup will get moved down towards the end of the tunnel (starting for RG-D experiments)
- Work to be accomplished in current scheduled accelerator down
- Phase 2 upgrade requires entirely new high-power dump
  - To be developed over the next few years

## 2. Software Developments/Planned Upgrades:

- AI/ML Upgrades for improved track reconstruction
- Denoising DC reconstruction
- Displaced vertex for finder for hyperon identification by Veronique
- Improved DC tracking by Tongtong
- AI/ML level-3 trigger running on GPUs

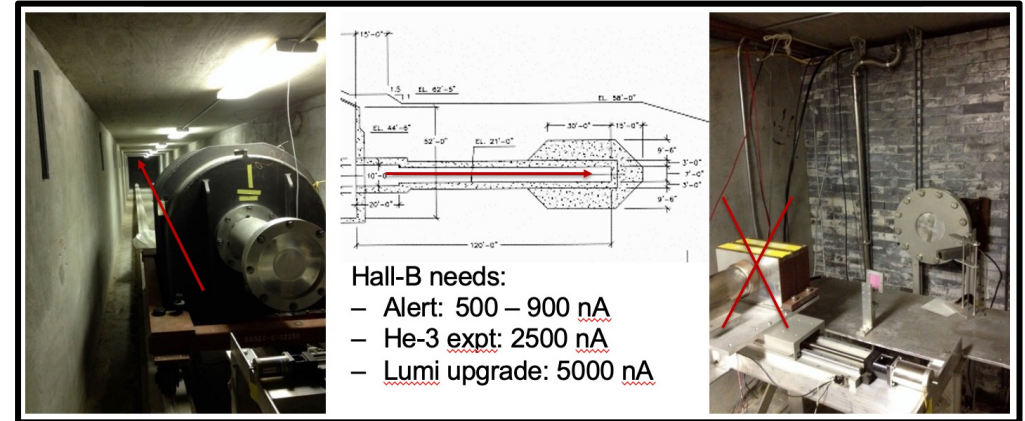

# Hall B – Planned Upgrades/Developments

## 3. Other Developments/Planned Upgrades:

- Expanding R&D activities in Micro Patterned Gaseous Detectors Lab
- $\mu$ RWELL development for luminosity upgrade to  $L = 2 \times 10^{35} \text{cm}^{-2} \text{sec}^{-1}$ 
  - With capacitive sharing readout provides 2D points in front of drift chambers
  - Work on prototype at UVA, CERN, and Jlab (implemented in part of one sector during last week of RG-C)
  - Time frame for completion is: 2-3 years
- Upgrade of HyCal Calorimeter
  - Will receive new high-resolution crystals and Flash ADCs
  - To be used in non-CLAS12 experiments such as: X17, dark photon search, and proton form factor measurements

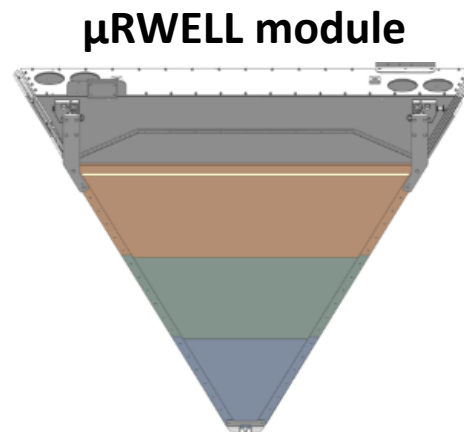
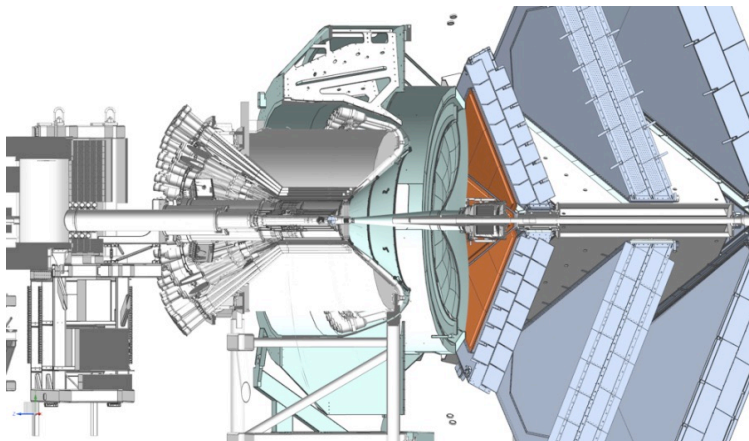

**HyCal Calorimeter**

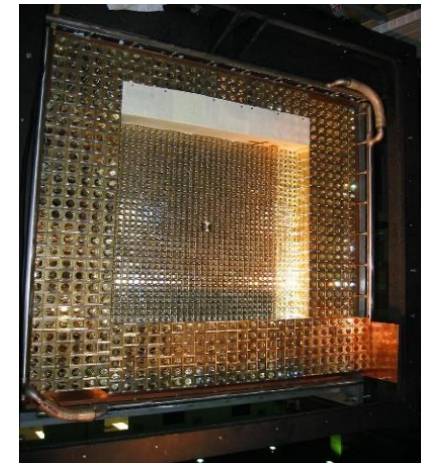

# Summary

- RG-C successfully conducted first polarized target experiment with CLAS12
  - To begin review/calibrations in the coming months
- RG-D is about to begin its experiments soon
- Tracking/reconstruction upgrades, mostly AI assisted, improve performance
- Detector and beam dump upgrades are progressing
  - $\mu$ RWELL operation will take time before completion
- Several publications submitted/accepted and analyses in review
  - See back-up slides for more details on some of the ongoing work from Hall B
    - Slides collected by Patrick Achenbach

**Thank you**

**Questions?**



# Backup Slides

# Data Analysis Results in Publication

## Multi-dimensional mapping of the nucleon

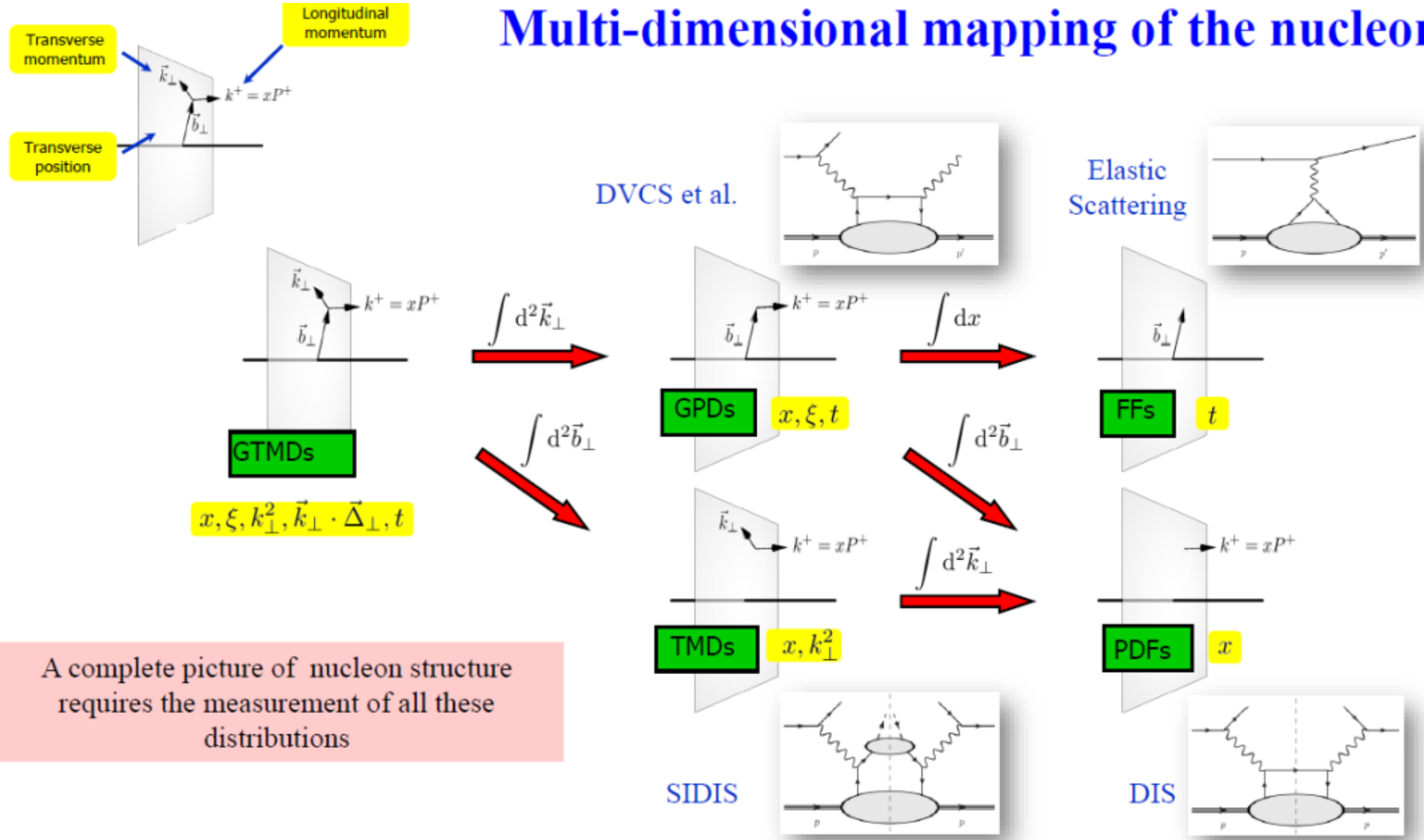

A complete picture of nucleon structure requires the measurement of all these distributions

Open Access

## Observation of Correlations between Spin and Transverse Momenta in Back-to-Back Dihadron Production at CLAS12

H. Avakian *et al.* (CLAS Collaboration)

Phys. Rev. Lett. **130**, 022501 – Published 11 January 2023

- First back-to-back analysis of proton- $\pi^+$  RGA data
- Sizable nonzero asymmetries  
→ first ever observation of a signal sensitive to TMD fracture functions
- PRL published last month
- Follow-up analysis involving RGA and RGB in order to study flavor dependence of fracture functions and both positive and negative pions in order to control systematics and test universality
- Analysis note ~90% completed, finalizing two remaining systematic uncertainties and working on cross check

First access to a TMD fracture function

$$\begin{aligned} \mathcal{A}_{LU} &= -\sqrt{1-\epsilon^2} \frac{\mathcal{F}_{LU}^{\sin \Delta\phi}}{\mathcal{F}_{UU}} \sin \Delta\phi \\ &= -\sqrt{1-\epsilon^2} \frac{|\vec{P}_{T1}||\vec{P}_{T2}|}{m_N m_2} \frac{\mathcal{C}[w_3 \hat{t}_1^{\perp h} D_1]}{\mathcal{C}[\hat{u}_1 D_1]} \sin \Delta\phi \end{aligned}$$

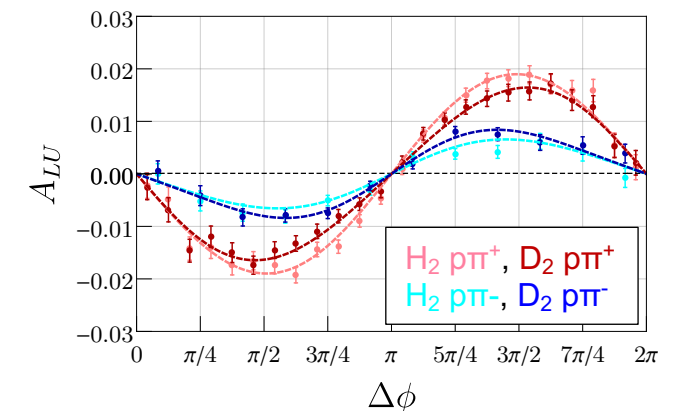
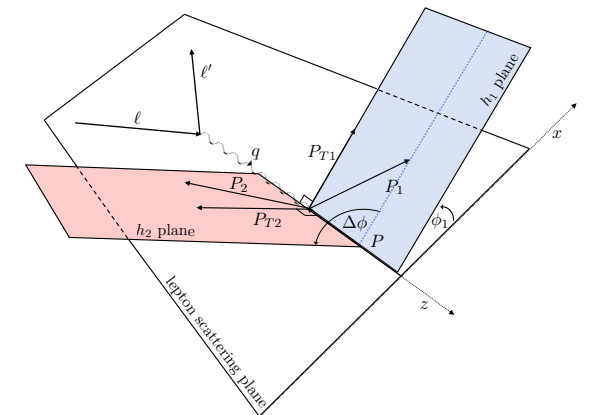



# Hard Exclusive $\pi^+$ Electro-Production off Protons

A multidimensional study of the structure function ratio  $\sigma_{LT'}/\sigma_0$  from hard exclusive  $\pi^+$  electro-production off protons in the GPD regime

S. Diehl<sup>ah,f</sup>, A. Kim<sup>f</sup>, K. Joo<sup>f</sup>, P. Achenbach<sup>an</sup>, Z. Akbar<sup>au,l</sup>,

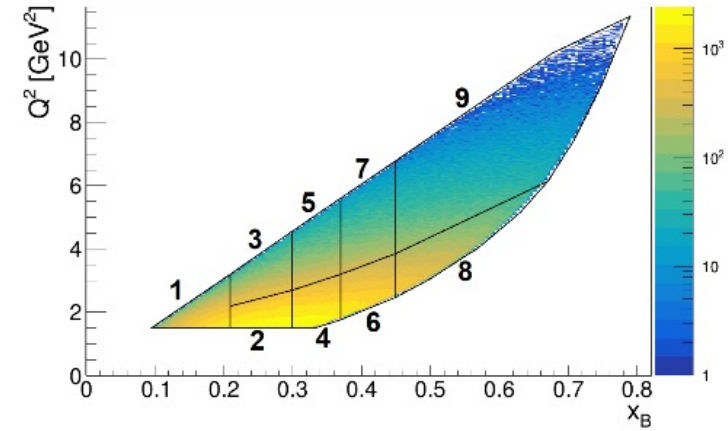
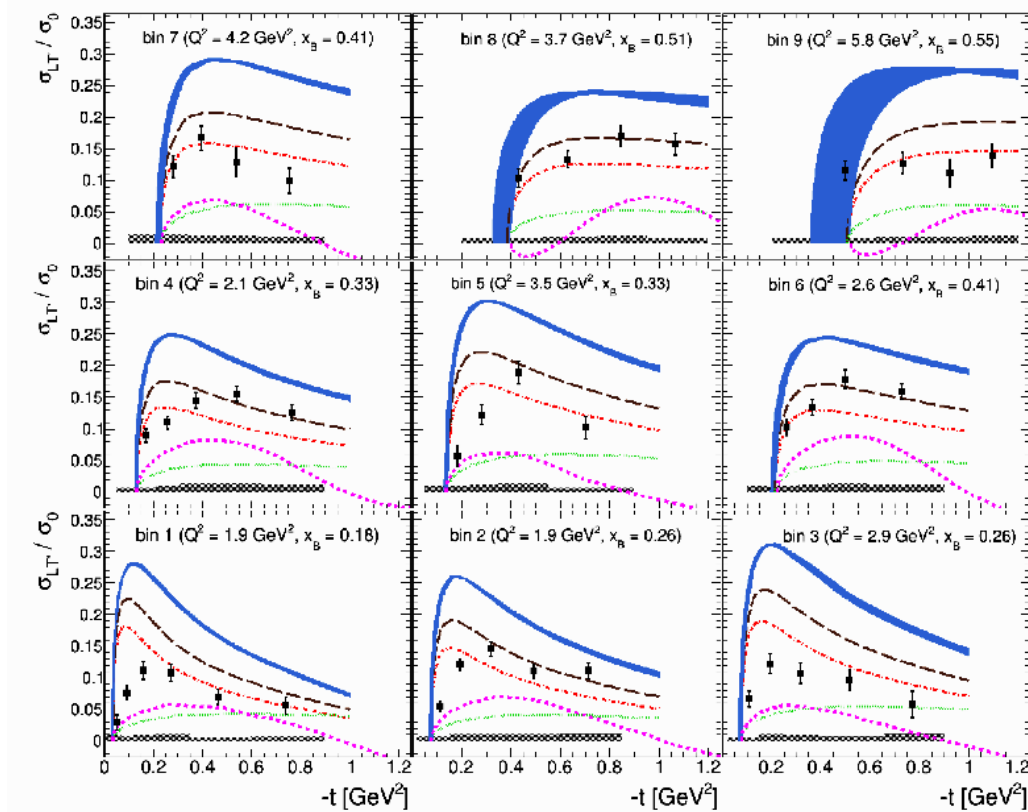

$$\frac{\sigma_{LT'}}{\sigma_0} \sim \frac{\text{Im} \left[ \langle H_{T\text{-eff}} \rangle^* \langle \tilde{E}_{\text{eff}} \rangle \right]}{|\langle H_{T\text{-eff}} \rangle|^2 + \epsilon \sigma_L}$$

- Published in PLB 839, 137761 (2023)

# Hard Exclusive $\pi^- \Delta^{++}$ Electro-Production BSA off Protons

First measurement of hard exclusive  $\pi^- \Delta^{++}$  electroproduction beam-spin asymmetries off the proton

S. Diehl,<sup>1,2</sup> N. Trovati,<sup>2</sup> and K. Joo<sup>2</sup>  
(The CLAS Collaboration)

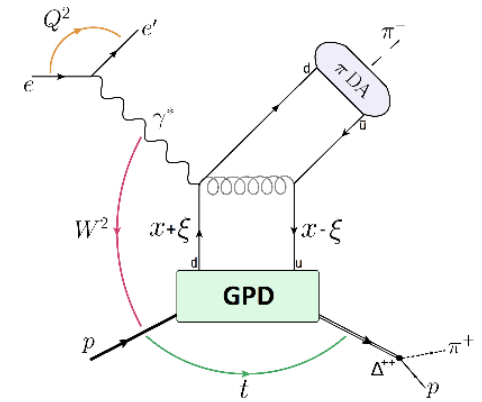
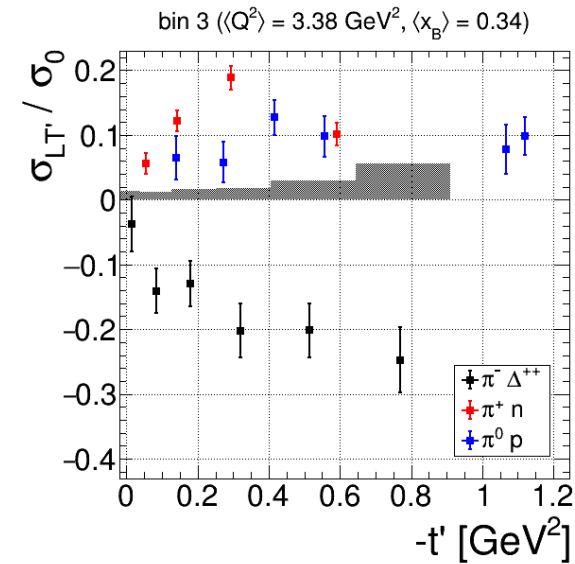
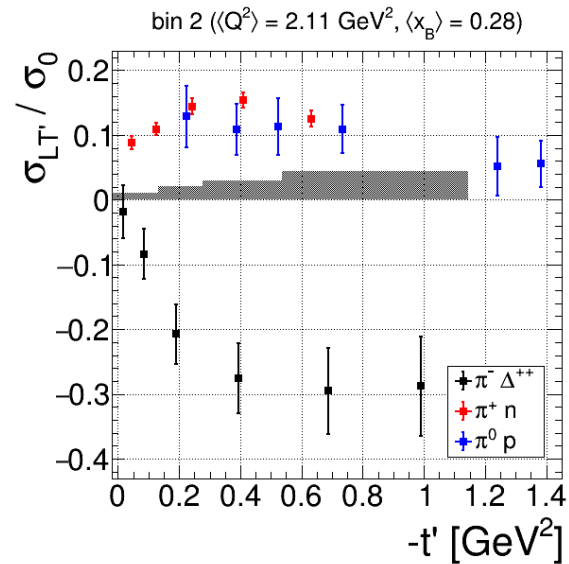
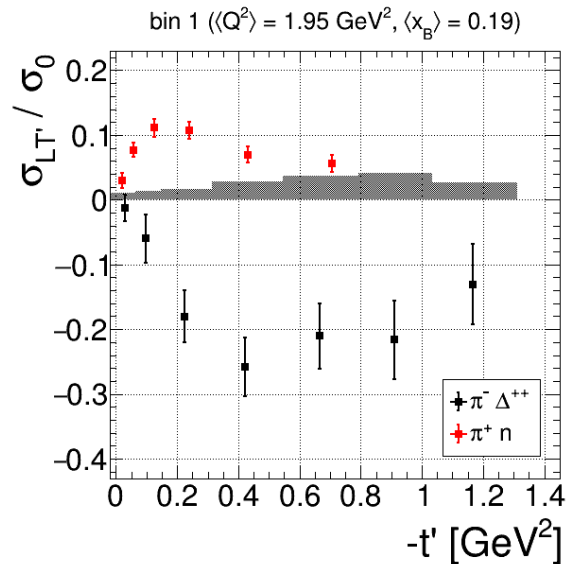

- Access to transition GPDs
- 3D structure of resonances
- Collaboration review started this week
- Paper expected to be submitted to PRL in March

# Multidimensional Study of SIDIS Single $\pi^-$ and $\pi^0$ BSA

A multidimensional study of SIDIS  $\pi^-$  and  $\pi^0$  beam spin asymmetry over a wide range of kinematics in the valence quark regime.

Stefan Diehl<sup>1,2</sup>, Andrey Kim<sup>2</sup>, Kyungscon Joo<sup>2</sup>

1D:

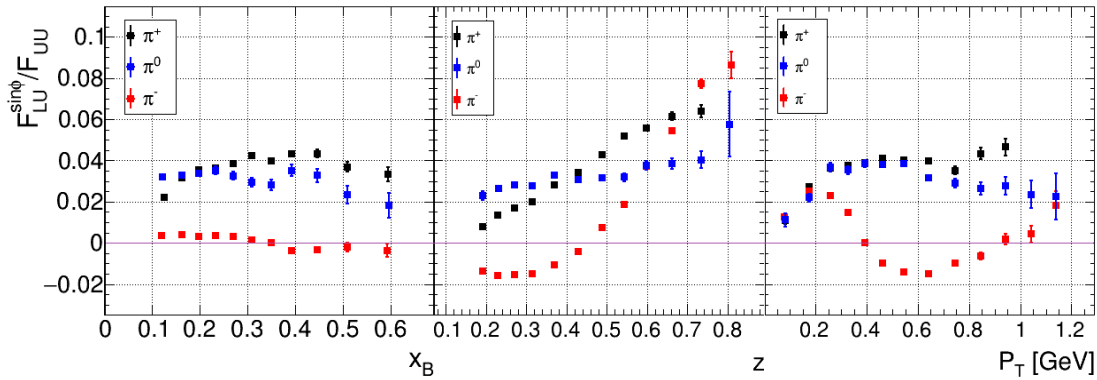

- Second round of the analysis review ongoing since January
- Extension of published  $\pi^+$  SIDIS
- Flavor decomposition of TMDs

4D:

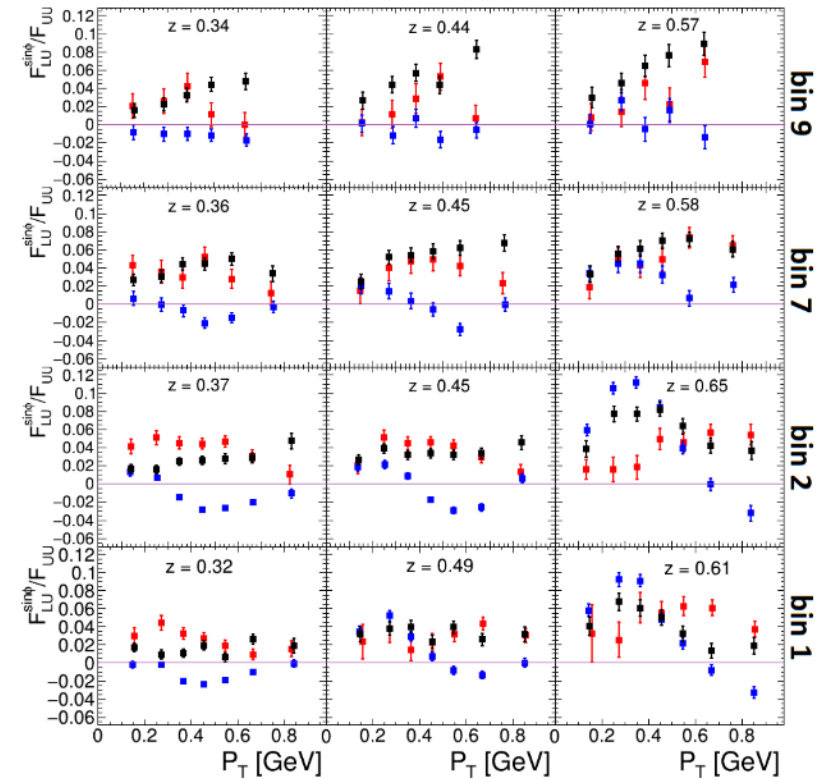

black:  $\pi^+$   
red:  $\pi^0$   
blue:  $\pi^-$

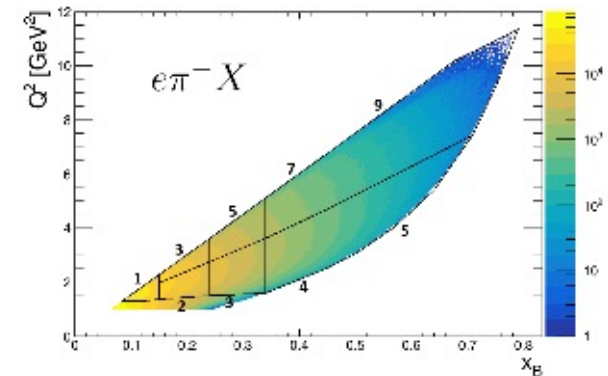

# Inclusive (e,e'X) Cross Section

- First results on inclusive (e,e'X) cross sections at  $4.0 \text{ GeV}^2 < Q^2 < 10 \text{ GeV}^2$
- Large coverage in  $W$  and  $Q^2$
- New opportunities for insight into PDF in resonance region and for exploration of quark-hadron

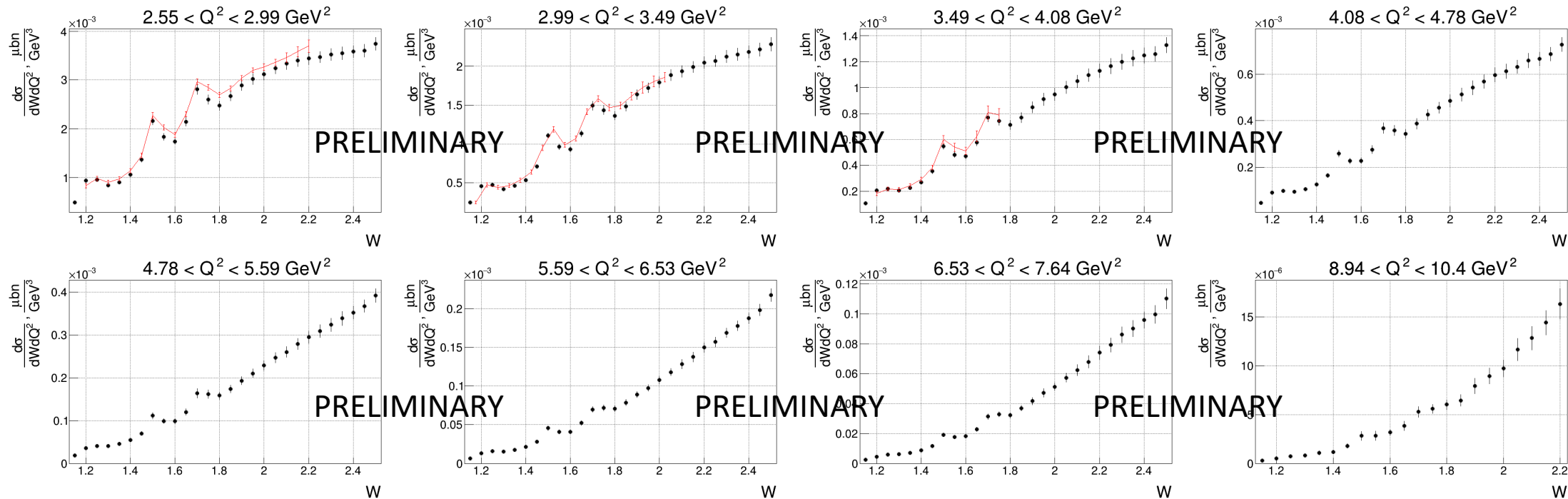

- Analysis note and draft of paper submission by first half 2023

- Black - preliminary cross sections
- Red - CLAS data, Phys. Rev. D67, 092001 (2003)

# SIDIS kinematics for $\Lambda$ electroproduction with CLAS6

## First Measurement of $\Lambda$ Electroproduction off Nuclei in the Current and Target Fragmentation Regions

T. Chetry,<sup>3</sup> L. El Fassi,<sup>3,\*</sup> W. K. Brooks,<sup>5,4,6,7</sup> R. Dupré,<sup>2</sup>  
A. El Alaoui,<sup>5</sup> K. Hafidi,<sup>1</sup> K. P. Adhikari,<sup>3</sup> and M. L. Kabir<sup>3</sup>

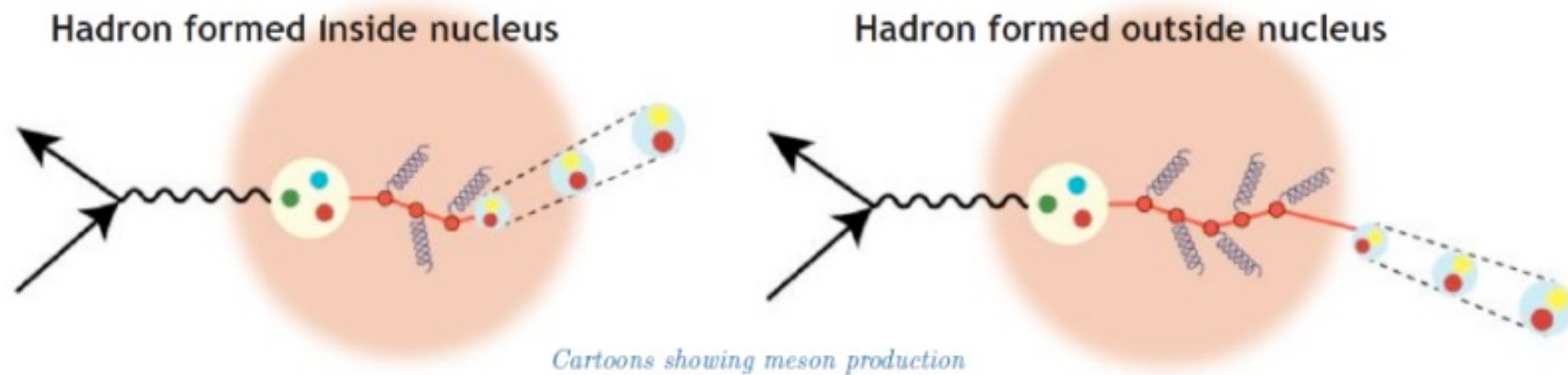

- Probing QCD Dynamics
- Study of transverse momentum broadening and multiplicity ratio
- Paper submitted to PRL, under review

# DVCS Beam-Spin Asymmetries

First CLAS12 measurement of DVCS beam-spin asymmetries in the extended valence region

G. Christiaens,<sup>1,2</sup> M. Defurne,<sup>1,\*</sup> D. Sokhan,<sup>1,2</sup> P. Achenbach,<sup>3</sup> Z. Akbar,<sup>4</sup> M.J. Amarian,<sup>5</sup> H. Atac,<sup>6</sup> C.

$$ep \rightarrow e'p'\gamma$$

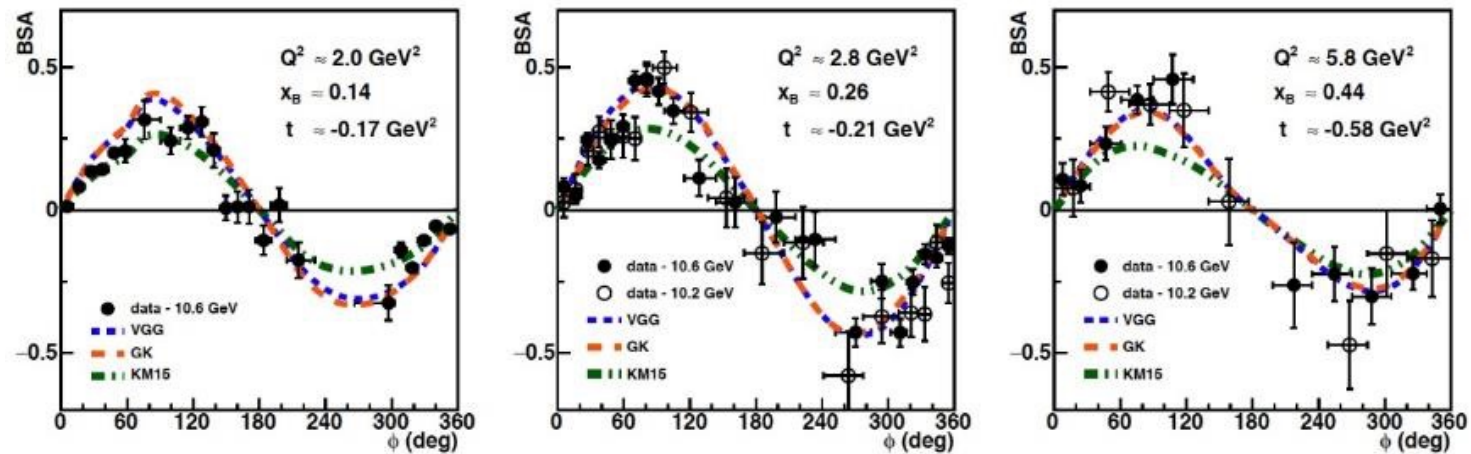

- Greatly extend the  $Q^2$  and Bjorken- $x$  phase space
- Submitted to PRL

# Heavy Photon Search 2016 Run

Searching for Prompt and Long-Lived Dark Photons in Electro-Produced  $e^+e^-$  Pairs with the Heavy Photon Search Experiment at JLab

P. H. Adrian,<sup>1</sup> N. A. Baltzell,<sup>2</sup> M. Battaglieri,<sup>3</sup> M. Bondí,<sup>4</sup> S. Boyarinov,<sup>2</sup> C. Bravo,<sup>1,\*</sup> S. Bueltmann,<sup>5</sup> P. Butti,<sup>1</sup>

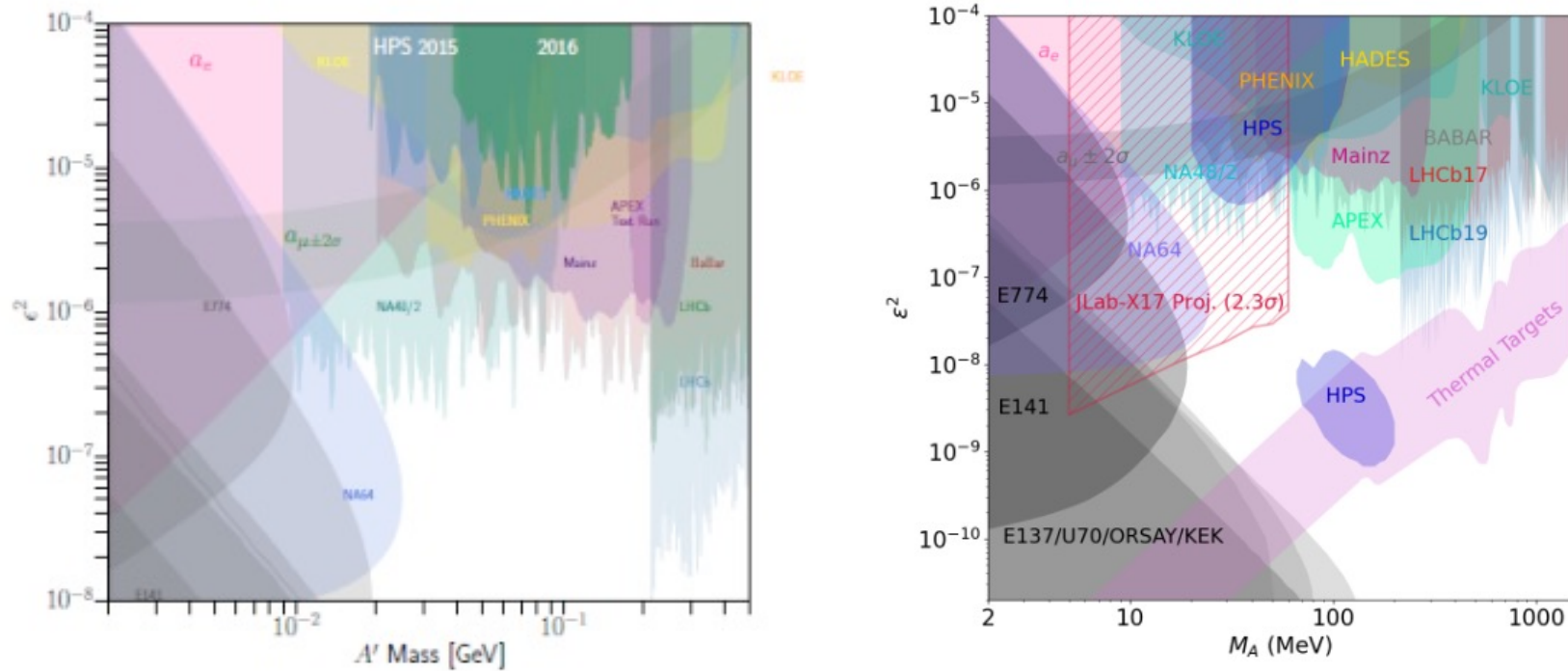

- Including bump hunt and displaced vertex analysis
- Submitted to PRD

# Beam Spin Asymmetry for Deeply Virtual Kaon Production

A multidimensional study of charged kaon  
SIDIS beam spin asymmetry over a wide range  
of kinematics

Áron Kripkó<sup>1</sup>, Stefan Diehl<sup>1,2</sup>, Utsav Shrestha<sup>2</sup>

- First round of the analysis review finished in November
- Finalizing the response to the first round
- Second round of the analysis review expected



# Beam Spin Asymmetry for Deeply Virtual $\pi^0$ Production

Andrey Kim (UConn)

$$\sigma_{LT'} \sim \xi \sqrt{1 - \xi^2} \frac{\sqrt{-t'}}{2m} \text{Im}[\langle \bar{E}_T \rangle^* \langle \tilde{H} \rangle + \langle H_T \rangle^* \langle \tilde{E} \rangle]$$

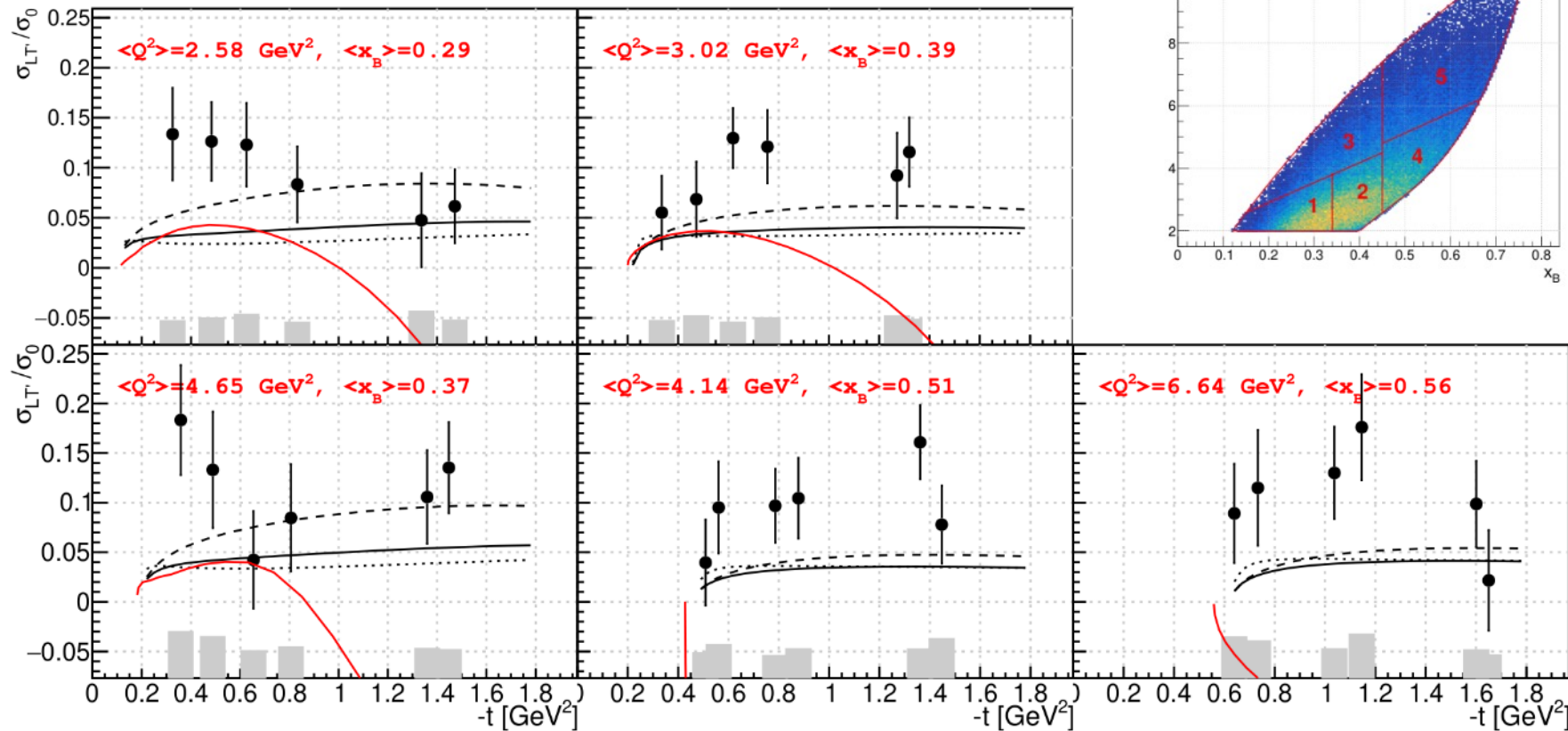

Paper is under the CLAS ad-hoc review (round 1)

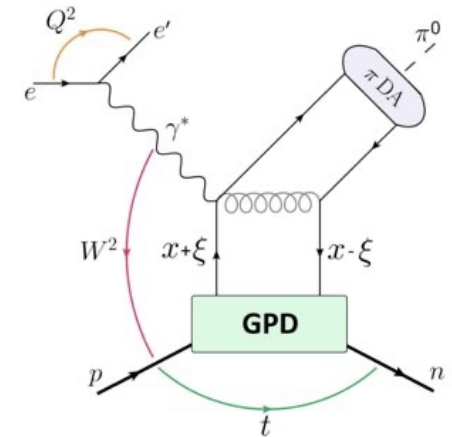

FIG. 1. Hard exclusive electroproduction of a pion on the proton in very forward kinematics ( $-t/Q^2 \ll 1$ ), described by GPDs [22, 23].

# Deeply Virtual Neutral Pion Cross Section

Robert Johnston (MIT)

## Deeply Virtual $\pi^0$ Production (DV $\pi^0$ P)

$$e + p \rightarrow e' + p' + \pi^0 \rightarrow e' + p' + \gamma_1 + \gamma_2$$

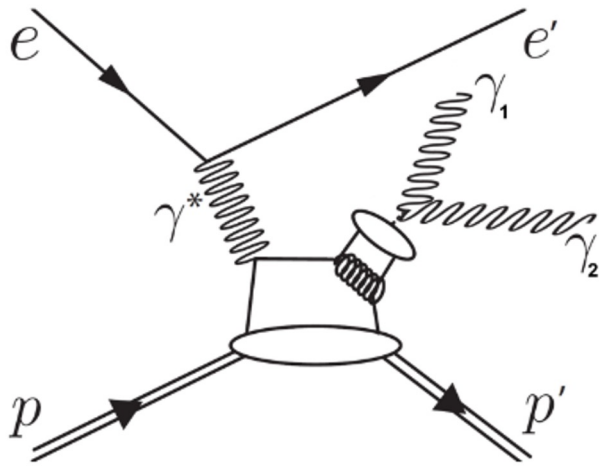

- CLAS12 data significantly extends kinematic reach compared to previous measurements and with higher statistics

- Currently calculating correction factors and systematic uncertainties to arrive at quantitative conclusions

## Kinematic Reach

$Q^2$  vs.  $x_B$  - CLAS12

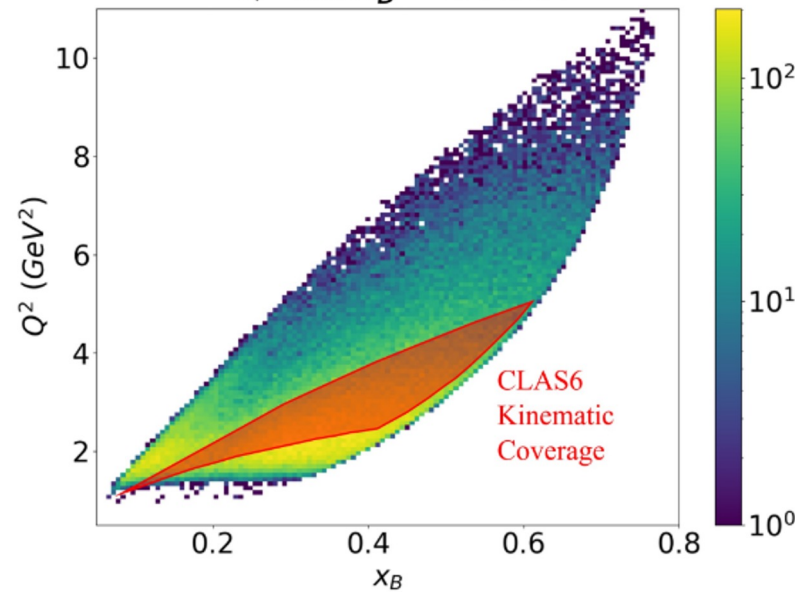

## Model Predictions

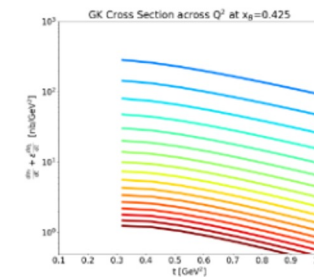
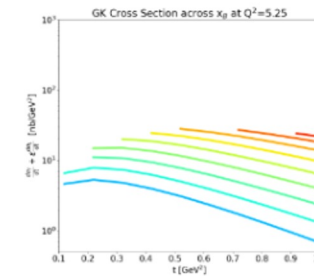

## GK and CLAS12 Data

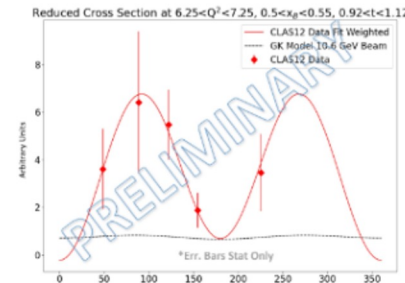
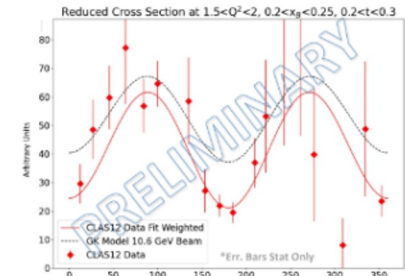

- Process is sensitive to chiral-odd GPDs, distinct from DVCS

# Beam Spin Asymmetry for Exclusive Vector Meson $\rho^0$ Electroproduction

Nicholaus Trotta (UConn), Kyungseon Joo (UConn), Andrey Kim (UConn)

- $ep \rightarrow ep^0(p)$ :  $\rho^0$  decays into  $\pi^+\pi^-$ , protons are identified by missing mass, pions only in Forward Detector
- Exclusive vector meson  $\rho^0$  channel is sensitive to GPDs  $H$ ,  $E$  at leading twist and  $H_T$  and  $\overline{E}_T$  at next leading twist

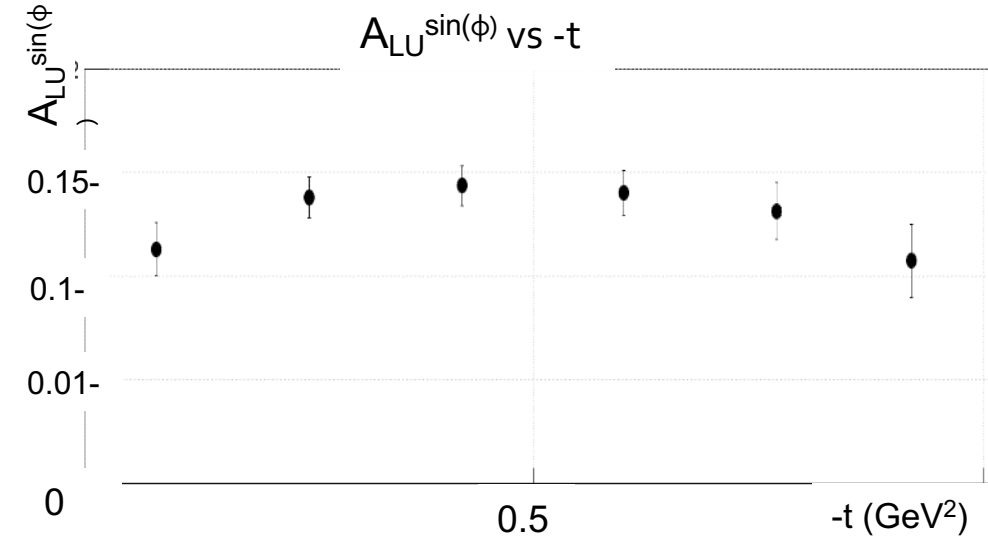
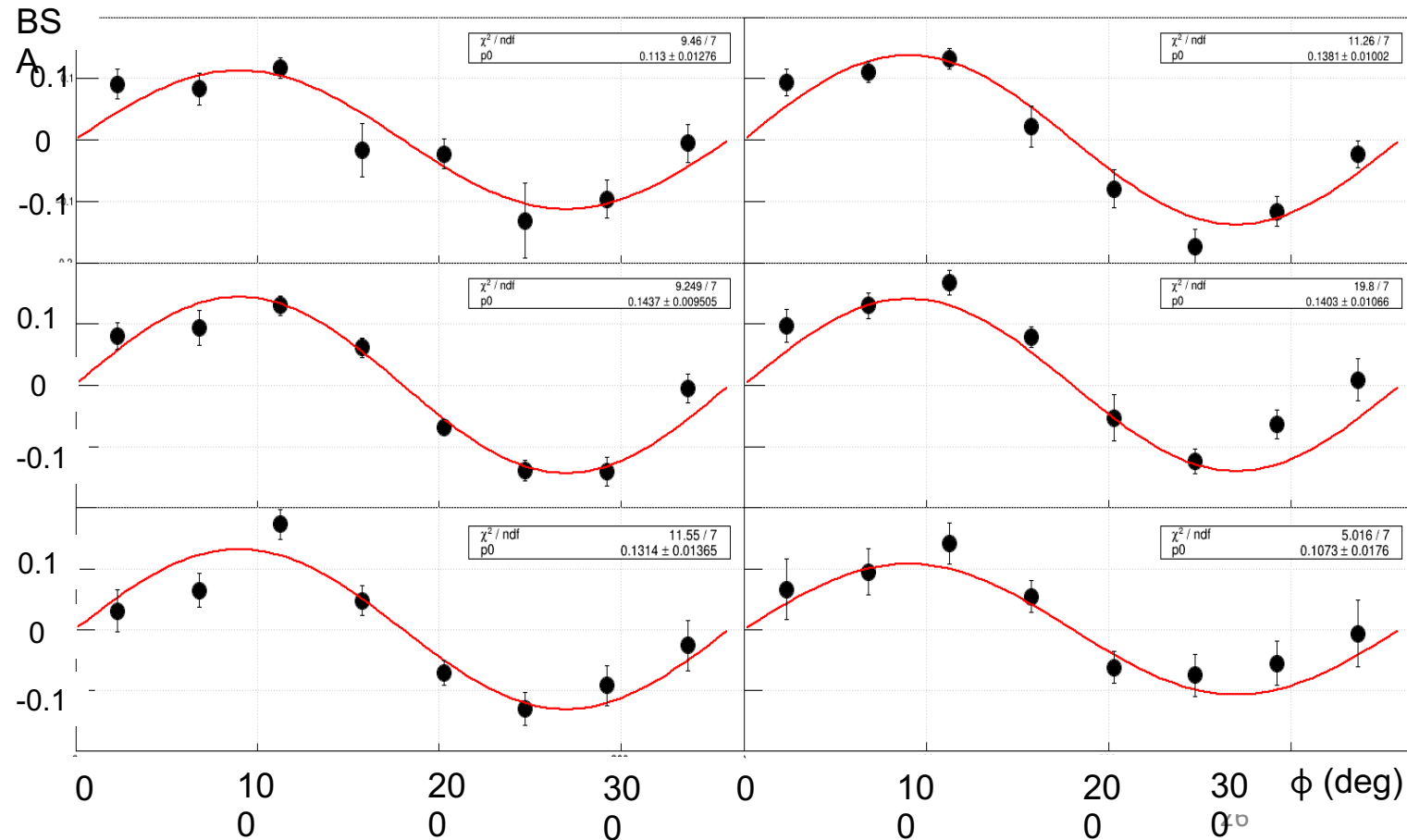

Invariant Mass  $\pi^+\pi^-$  ( $0 < \phi < 45$ ;  $0.23 < -t < 0.46$ )

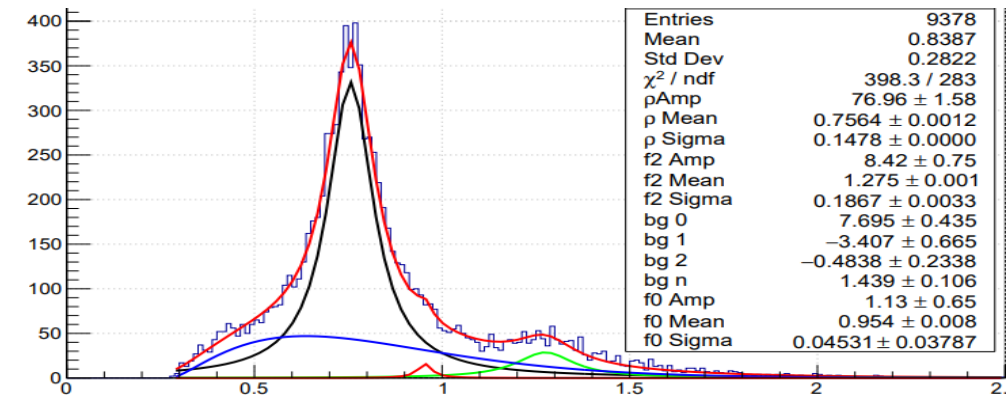

# Cross section for $J/\psi$ photoproduction

Pierre Chatagnon (Jefferson Lab) & Richard Tyson (Glasgow)

## Analysis status

- Event selection and particle identification
- Additional use of AI to identify leptons above 4 GeV
- Irreducible backgrounds (from photon conversion and pion decays) are subtracted using same-charge lepton events
- Overall normalization factors obtained from Bethe-Heitler events
- Cross-section extracted for proton (both electron-positron and di-muon channel), bound neutrons and bound protons

Figure 1: Output spectrum of the BDT used to distinguish leptons from pions at momenta larger than 4 GeV. The BDT uses all information from the electromagnetic showers provided by the CLAS12 calorimeter.

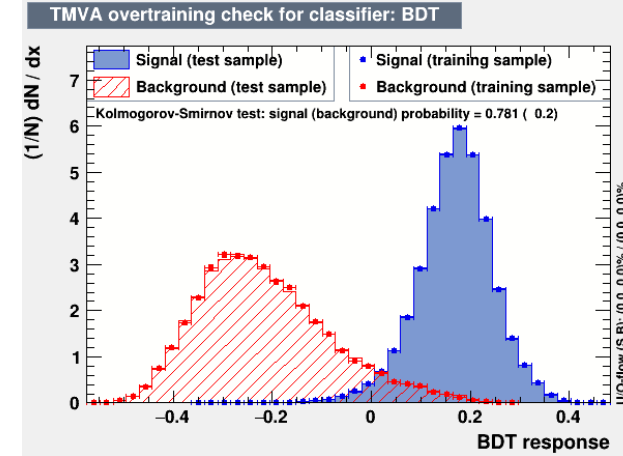

## Path forward

- Ongoing studies to better understand the overall normalization, especially understand the particle detection efficiencies in both data and Monte-Carlo
- Upcoming pass 2 data will provide greatly improved tracking efficiency, providing significantly more statistics
- Systematic uncertainties remain to be studied

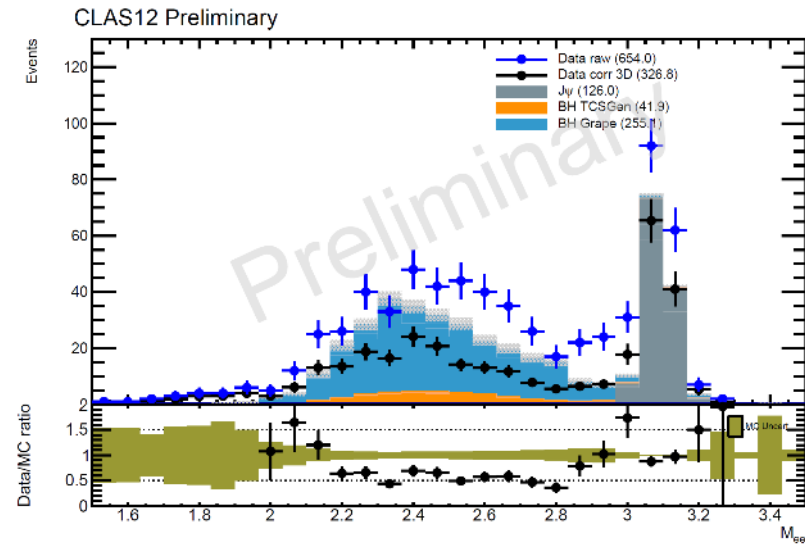

Figure 2: Invariant mass spectrum of the lepton pair after irreducible background subtraction, compared the normalized yields from Monte-Carlo simulation

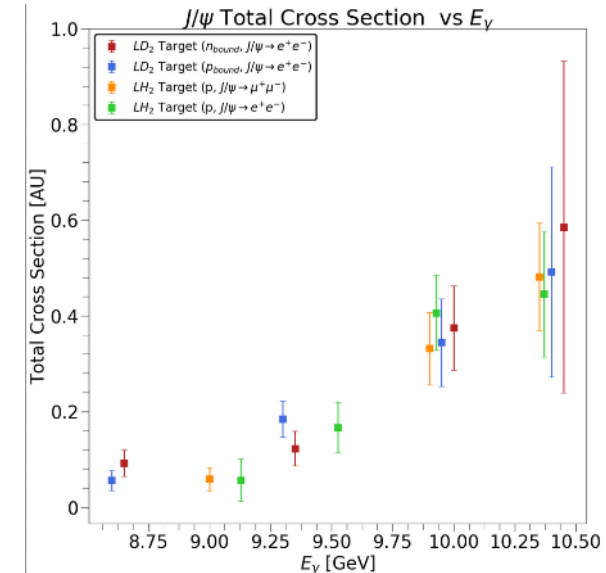

Figure 3: Unnormalized cross-section extracted from proton, bound neutron and bound proton in both final state of interest

# Beam Spin Asymmetries for $\pi^\pm \pi^0$ Dihadron Production

Gregory Matousek (Duke University)

Beam spin asymmetries of dihadron SIDIS allow for **targeted extraction** of the twist-3 PDF  $e(x)$  and twist-2 DiFF  $G_1^\perp$

$$ep \rightarrow e' \pi^\pm \pi^0 X \text{ channel supplements published } \pi^+ \pi^- \text{ results}$$

**Main Challenge:**  $\pi^0 \rightarrow \gamma\gamma$  has large combinatorial background

- Requires sideband (or *sWeighting*) procedure for projecting out background asymmetries
- Strict event cuts, *increasing purity yet decreasing statistics*

**Solution:** Train a GBTs model to classify SIDIS photons from bkg.

**Inputs:** Train on 3 feature types:

- Event-wide information
- Photon intrinsic ( $E, \theta, \dots$ )
- Intrinsic to photon's Nearest Neighbors (N-N)

**Outputs:**  $0 < p < 1$  prediction score for each photon

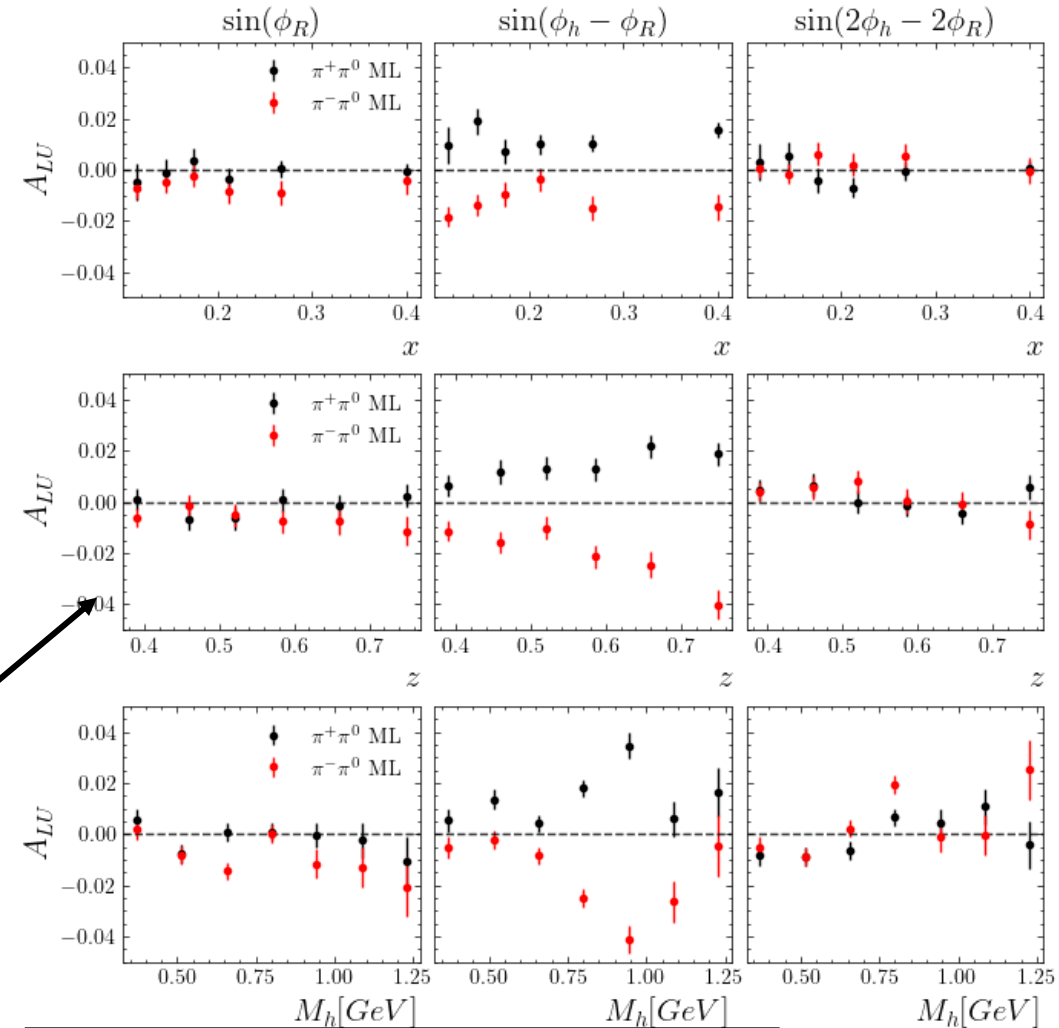
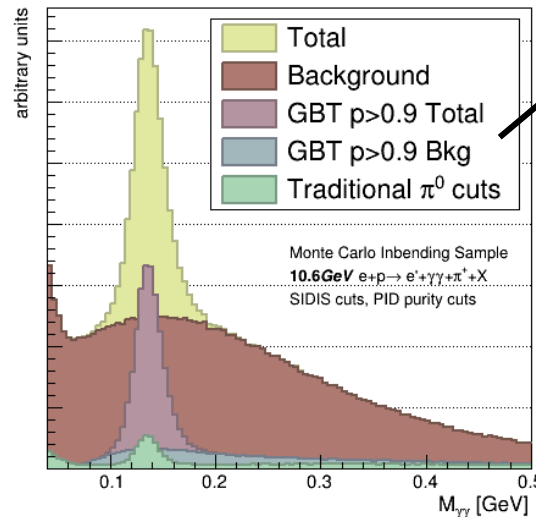

- New N-N approach rejects photons created by secondary interactions

- GBT asymmetries consistent with old approach
- Factor of 4 error reduction for asymmetries
- Statistics are large enough for 2d binning
- Potential for  $\pi^0 \pi^0$  dihadrons

# Studies of Proton Fracture Functions in $ep \rightarrow epX$

Fatiha Benmokhtar and Students, Harut Avakian and Timothy Hayward

$$\frac{d\sigma}{dx dy d\zeta dP_T^2 d\phi_h} = \hat{\sigma}_U \left\{ F_{UU,T} + \varepsilon F_{UU,L} + \sqrt{2\varepsilon(1+\varepsilon)} F_{UU}^{\cos\phi_h} \cos\phi_h \right. \\ \left. + \varepsilon F_{UU}^{\cos 2\phi_h} \cos 2\phi_h + \lambda_\ell \sqrt{2\varepsilon(1-\varepsilon)} F_{LU}^{\sin\phi_h} \sin\phi_h \right\}$$

A. Kotzinian, Nucl. Phys., vol. B441, pp. 234-248, 1995.

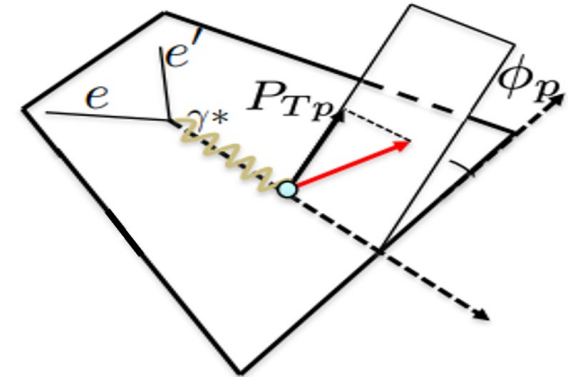

$x_F$  — frac. Momentum in the CM frame

Current fragmentation,  $x_F > 0$

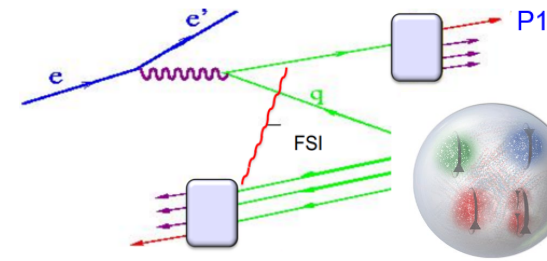

Target fragmentation,  $x_F < 0$

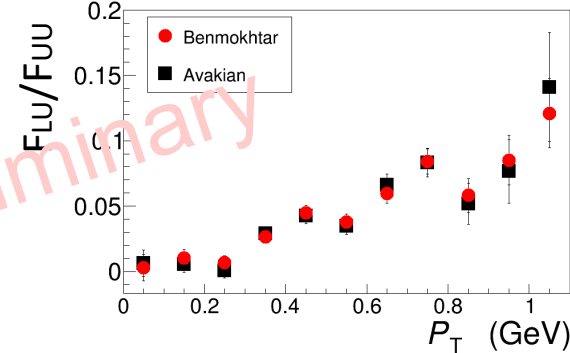
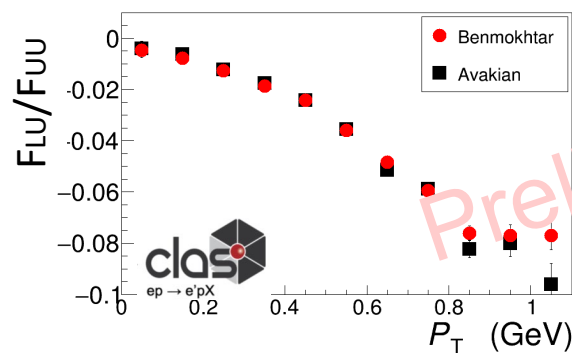
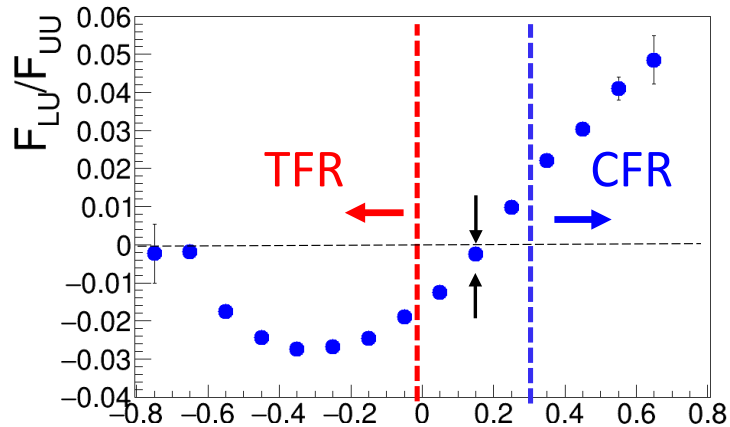

## Analysis status:

- Both 2018 fall and spring 2019 RGA inbending  $ep \rightarrow epX$
- Energy loss correction to the asymmetry, done
- Multi-Dim analysis on asymmetry done on  $x_F$ ,  $M_X$ ,  $Q^2$ ,  $P_T$  etc...
- Fracture functions for some variables are extracted
- Next steps: systematic corrections
- Target goal for submitting to PRL, summer 2023

# Neutral Pion Multiplicity in SIDIS

Marshall B. C. Scott (ANL)

- Number of neutral pions generated in the five-dimensional SIDIS phase space  $(x, Q^2, z, p_T^2, \varphi_h)$  divided by the DIS phase space  $(x, Q^2)$ .
- Related to the  $D^0(z)$  fragmentation function describing the probability of quarks fragmenting into neutral pions, and further serve as a test on the isospin symmetry between  $D^0(z)$  and the charged pion fragmentation functions.
- Extraction of cosine moments from  $\varphi_h$  dependence and studying the acceptances utilizing bin-by-bin and multidimensional unfolding methods.
- Preliminary results will be presented at upcoming April APS meeting.

Example Multiplicities for one  $x$ - $Q^2$  Bin

**$x$ - $Q^2$  Bin 1 :  $M_H(z)$**

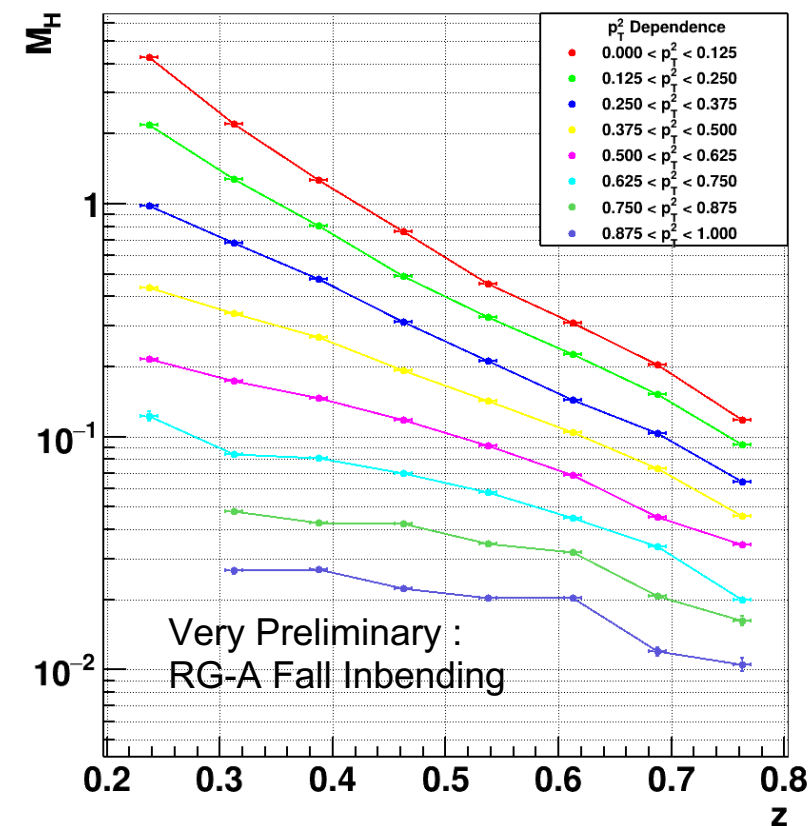

$(x, Q^2)$  phase space : triangular bin from point  $(0.15, 2.28)$  to  $(0.24, 2.75)$  to  $(0.24, 3.63)$

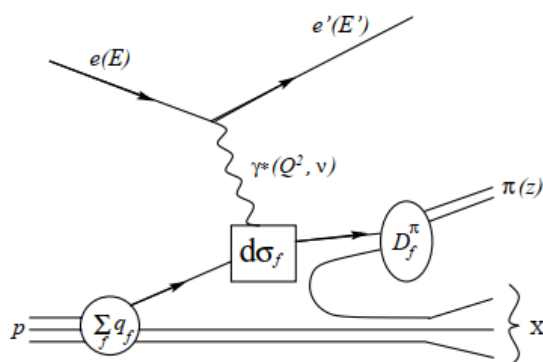
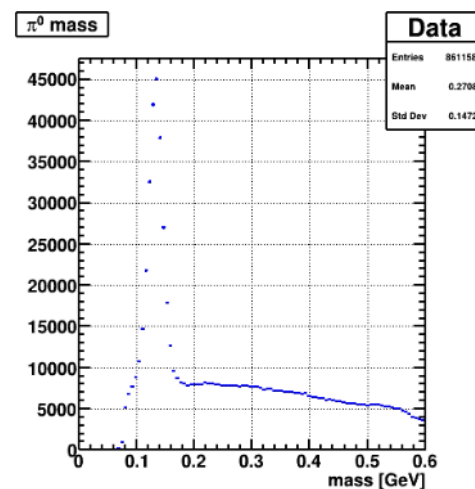

Fig. 1. Semi-inclusive pion electroproduction diagram



# Measurements of the $\cos\phi_h$ and $\cos 2\phi_h$ Moments of the Unpolarized SIDIS $\pi^+$ Cross-section at CLAS12

Richard Capobianco  
(UCONN/Argonne)

- Working towards the extraction of the  $\cos(\phi_h)$  and  $\cos(2\phi_h)$  moments of unpolarized SIDIS cross-section for charged pions using RG-A data
- The collected statistics enable a high-precision study of these azimuthal moments which probe the Boer-Mulders function and Cahn effect
- The high statistics data will, for the first time, enable a multidimensional analysis of both moments over a large kinematic range of  $Q^2$ ,  $x_B$ ,  $z$ , and  $P_T$ .

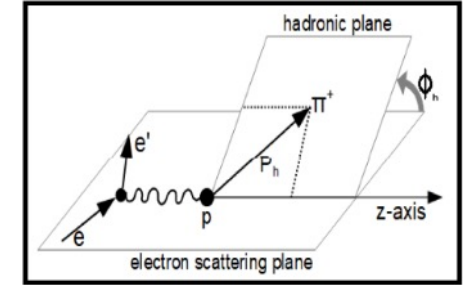

## The lepton-hadron Unpolarized SIDIS Cross-Section:

$$\frac{d^5\sigma}{dx dQ^2 dz d\phi_h dP_{h\perp}^2} = \underbrace{\frac{2\pi\alpha^2 y^2}{xyQ^2 2(1-\epsilon)} \left(1 + \frac{\gamma^2}{2x}\right)}_{A_0} (F_{UU,T} + \epsilon F_{UU,L}) \left\{ 1 + \underbrace{\frac{\sqrt{2\epsilon(1+\epsilon)} F_{UU}^{\cos\phi_h}}{(F_{UU,T} + \epsilon F_{UU,L})}}_{A_{UU}^{\cos\phi_h}} \cos\phi_h + \underbrace{\frac{\epsilon F_{UU}^{\cos 2\phi_h}}{(F_{UU,T} + \epsilon F_{UU,L})}}_{A_{UU}^{\cos 2\phi_h}} \cos 2\phi_h \right\}$$

## The Boer-Mulders and Cahn effects are present in the Structure Functions:

$$\begin{aligned} \text{leading twist } F_{UU}^{\cos 2\phi_h} &\propto C \left[ \frac{2(\hat{P}_{h\perp} \cdot \vec{k}_T)(\hat{P}_{h\perp} \cdot \vec{p}_T) - \vec{k}_T \cdot \vec{p}_T}{MM_h} h_1^\perp H_1^\perp + \dots \right] \text{ BOER-MULDERS EFFECT} \\ \text{next to leading twist } F_{UU}^{\cos\phi_h} &\propto \frac{2M}{M_h} C \left[ \frac{\hat{P}_{h\perp} \cdot \vec{k}_T}{M_h} x h H_1^\perp - \frac{\hat{P}_{h\perp} \cdot \vec{p}_T}{M} f_1 D_1 + \dots \right] \text{ CAHN EFFECT} \end{aligned}$$

Interaction dependent terms neglected

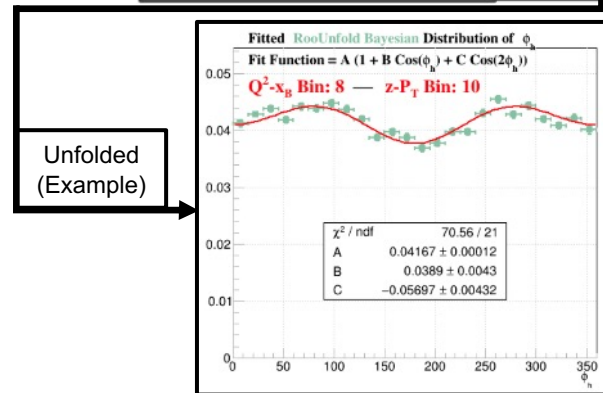
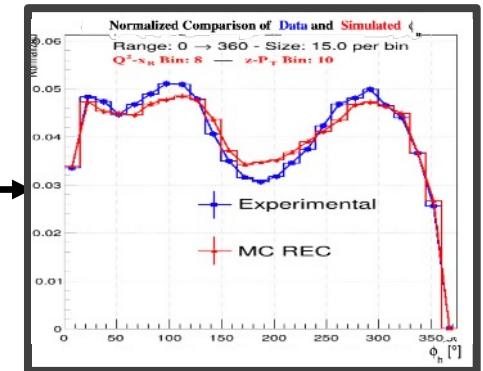
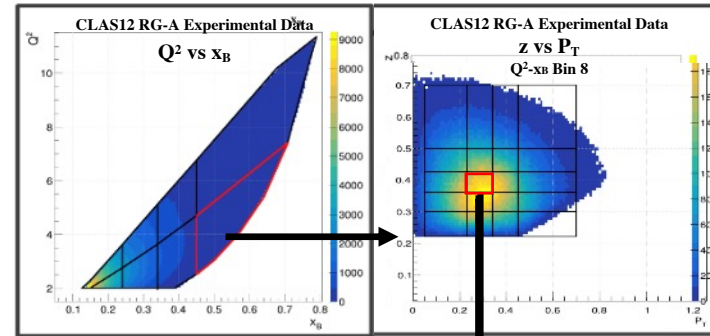

Reconstructed

Unfold the data using Simulated and Experimental data and fit the new distribution with the function:  
 $A + B \cos \phi_h + C \cos 2\phi_h$   
 Where A, B, and C will then be used to calculate the azimuthal moments from the cross-section equation

Do for every  $Q^2$ - $x_B$  and  $z$ - $P_T$  bin to get A, B, and C as functions of all 4 variables



# Summary of CLAS Physics Publications

## 2023 Publications

7. S. Diehl *et al.* (CLAS Collaboration), "First Measurement of Hard Exclusive  $\pi^- \Delta^{++}$  Electroproduction Beam Spin Asymmetries off the Proton", arXiv:2303.11762, submitted to Phys. Rev. Lett. (2023).
6. G. Christiaens *et al.* (CLAS Collaboration), "First CLAS12 Measurement of DVCS Beam-Spin Asymmetries in the Extended Valence Region", arXiv:2211.11274, submitted to Phys. Rev. Lett. (2022).
5. T. Chetry *et al.* (CLAS Collaboration), "First Measurement of  $\Lambda$  Electroproduction off Nuclei in the Current and Target Fragmentation Regions", Phys. Rev. Lett. 130, 14 (2023). ([Paper](#))
4. S. Diehl *et al.* (CLAS Collaboration), "A Multidimensional Study of the Structure Function Ratio  $\sigma_{LT'}/\sigma_0$  from Hard Exclusive  $\pi^+$  Electroproduction off Protons in the GPD Regime", Phys. Lett. B 839, 137761 (2023). ([Paper](#))
3. S. Paul *et al.* (CLAS Collaboration), "Alignment of the CLAS12 Central Hybrid Tracker with a Kalman Filter", Nucl. Inst. and Meth. A 1049, 168032 (2023). ([Paper](#))
2. H. Avakian *et al.* (CLAS Collaboration), "Observation of Correlations Between Spin and Transverse Momenta in Back-to-Back Dihadron Production at CLAS12", Phys. Rev. Lett. 130, 022501 (2023). ([Paper](#))
1. Y. Tian *et al.* (CLAS Collaboration), "Exclusive  $\pi^-$  Electroproduction off the Neutron in Deuterium in the Resonance Region", Phys. Rev. C 107, 015201 (2023). ([Paper](#))

## 2022 Publications

7. T. Hu *et al.* (CLAS Collaboration), "First Comprehensive Measurement of Spin Observables and Differential Cross Sections  $d\sigma/dt$  in  $\omega$  Photoproduction off the Proton for  $2.7 < E_\gamma < 5.2$  GeV Using CLAS", submitted to Phys. Rev. Lett. (2022).
6. S. Paul *et al.* (CLAS Collaboration), "Observation of Azimuth-Dependent Suppression of Hadron Pairs in Electron Scattering off Nuclei", Phys. Rev. Lett. 129, 182501 (2022). ([Paper](#))
5. D.S. Carman *et al.* (CLAS Collaboration), "Beam-Recoil Transferred Polarization in  $K^+Y$  Electroproduction in the Nucleon Resonance Region with CLAS12", Phys. Rev. C 105, 065201 (2022). (Summary: [1-page write-up](#)), ([Paper](#))
4. N. Zachariou *et al.* (CLAS Collaboration), "Beam-Spin Asymmetry  $\Sigma$  for  $\Sigma^-$  Hyperon Photoproduction off the Neutron", Phys. Lett. B 827, 136985 (2022). ([Paper](#))
3. E.L. Isupov *et al.* (CLAS Collaboration), "Polarized Structure Function  $\sigma_{LT'}$  from  $\pi^0 p$  Electroproduction Data in the Resonance Region at  $0.4 < Q^2 < 1.0$  GeV<sup>2</sup>", Phys. Rev. C 105, L022201 (2022). ([Paper](#))
2. S. Diehl *et al.* (CLAS Collaboration), "Multidimensional, High Precision Measurements of Beam Single Spin Asymmetries in Semi-Inclusive  $\pi^+$  Electroproduction off Protons in the Valence Region", Phys. Rev. Lett. 128, 062005 (2022). ([Paper](#))
1. S. Moran *et al.* (CLAS Collaboration), "Measurement of Charged Pion Production in Deep-Inelastic Scattering off Nuclei with the CLAS Detector", Phys. Rev. C 105, 015201 (2022). ([Paper](#))