

November 15, 2022

Imaging Calorimetry for the Electron-Ion Collider

EICGENR&D2022_25

PIs: Maria Żurek, Zisis Papandreou

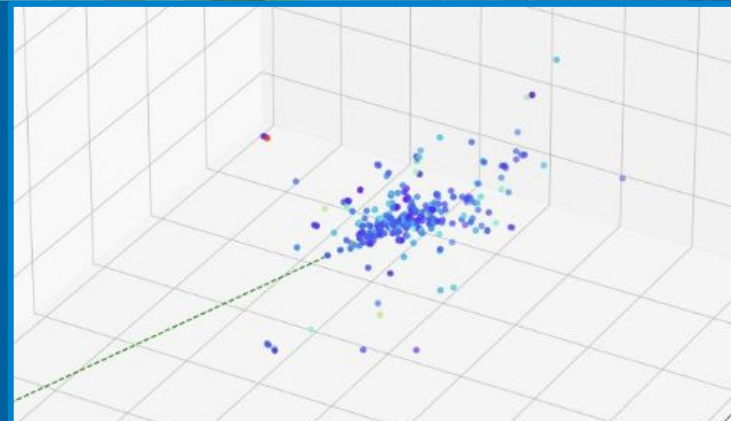

Maria Żurek, Argonne National Laboratory
for the EICGENR&D2022_25 Proposal Authors



UNIVERSITY OF CALIFORNIA
SANTA CRUZ



**University
of Manitoba**



**University
of Regina**

Argonne
NATIONAL LABORATORY

75
1946-2021

EIC Calorimetry Requirements

Barrel ECAL in EIC Yellow Report

EIC Community outlined physics, detector requirements, and evolving detector concepts in the [EIC Yellow Report](#).

EIC Yellow Report requirements for barrel ECal

- Detection of electrons/photons to measure **energy and position**
- Require **moderate energy resolution** $(10 - 12) \% \sqrt{E} \oplus (1 - 3) \%$
- Require **electron-pion separation up to 10^4** at low particle momenta
- Discriminate between **π^0 decays and single photons** from DVCS
- **Low energy photon** reconstruction ~ 100 MeV

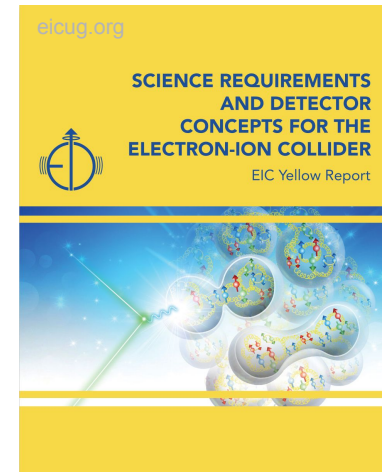

Challenges: e/π PID, γ/π^0 discrimination, dynamic range of sensors, available space

Imaging Calorimeter Concept for EIC

- **Hybrid concept**
 - Imaging calorimetry based on monolithic silicon sensors **AstroPix** (NASA's AMEGO-X mission) - 500 μm x 500 μm pixels NIM, A 1019 (2021) 165795
 - Scintillating fibers in Pb (Similar to **GlueX Barrel ECal**, 2-side readout w/ SiPMs) NIM, A 896 (2018) 24-42
- **6 layers of imaging Si sensors interleaved with 5 Pb/SciFi layers**
- Followed by a **large chunk of Pb/SciFi section** (can be "extended" to inner HCAL)
- Total radiation thickness for EMCAL of $\sim 21 X_0$ (**only ~ 38 cm! deep**)

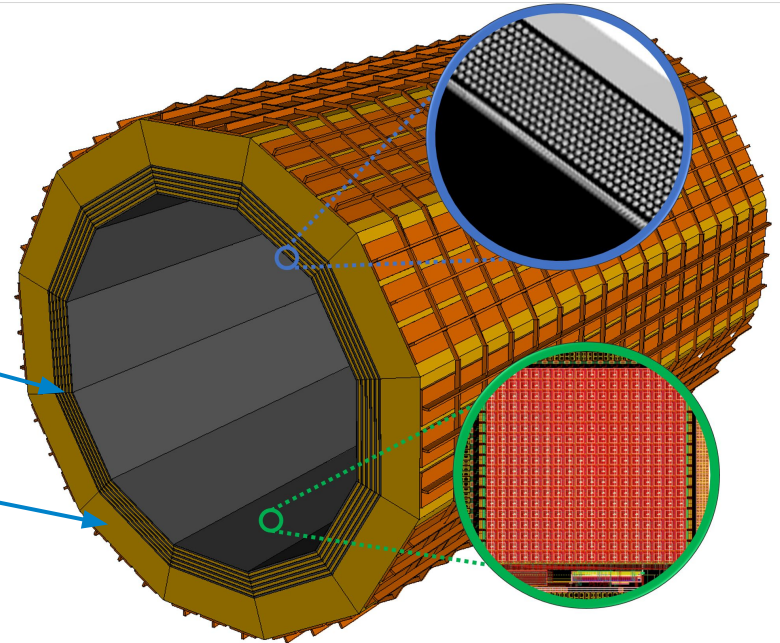

The generic R&D: investigate Pb/ScFi and Astropix technologies & their integration in the EIC environment

This proposal: assess Pb/ScFi technology utilizing a **GlueX barrel ECal** prototype

Imaging Calorimeter Concept

- **Combination of Pb/SciFi calorimeter with a silicon tracker** to precisely measure the energy profile and exact position of each particle inside electromagnetic showers - **3D shower imaging**
- Provides considerably **more information compared to traditional 2D calorimeters** which synergizes particularly well with event reconstruction approaches based on **ML/AI**

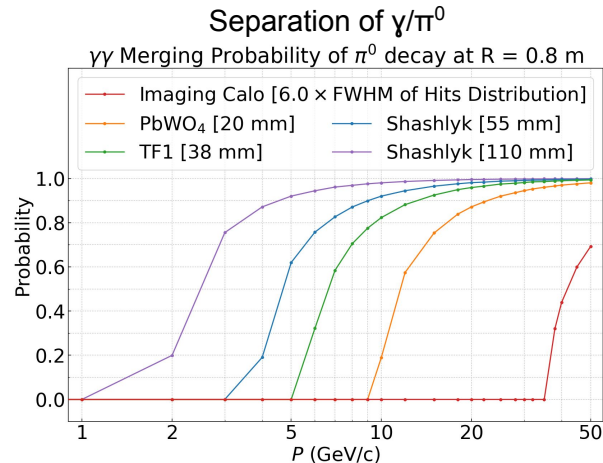
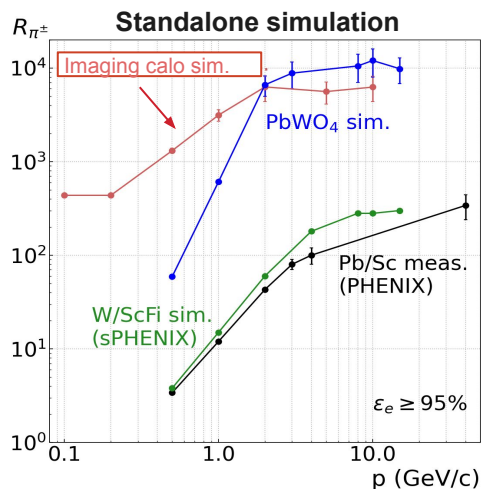

Energy resolution - SciFi/Pb Layers: $5.2\% / \sqrt{E} \oplus 1.0\%$

Position resolution - Imaging Layers (+ 2-side SciFi readout): with 1st layer hit information \sim pixel size

Goals of the project

- **Pb/ScFi tested** extensively in the energy range $E_\gamma < 2.5 \text{ GeV}$
 - At EIC energies up to $\sim 10 \text{ GeV}$ for γ and $\sim 40 \text{ GeV}$ for e
 - Higher-energy data important to constrain the constant term of energy resolution (Hall D, up to $\sim 6.2 \text{ GeV}$, FY23)
GlueX: $5.2\% \sqrt{E} \oplus 3.6\%$
- **Goals:**
 - Obtain responses to electromagnetic and hadronic showers to benchmark simulations and provide input to realistic waveform analysis
 - Primary tests with the SiMP readout, exploratory tests with the MCP-PMT readout
- This will be further used to optimize the detector design

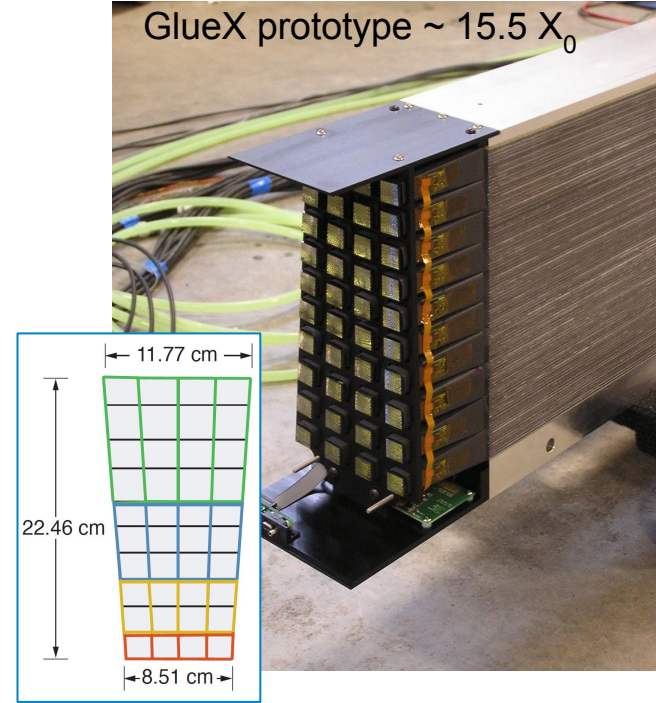

- 60-cm long prototype
- 40 light guides on either end
- 40 SiPMs per side

Goals of the project

Energy consideration

- **Higher-energy data** to constrain the **constant term of energy resolution (FY23)**
- Measurements **closer to the lower energy limits** input on the **linearity** of the detector responses and **achievable energy resolution (FY24+)**
- *Important for:* simulations of pion-electron separation based on **E/p method** and calorimeter performance for **reconstructing photons**

Beam-particles consideration

- Pion/proton data for realistic hadronic showers in simulations (**FY24**)
- *Important for:* simulations of pion-electron separation based on **E/p method** and performance as **inner hadronic calorimeter**

Readout consideration

- Natural cost-effective choice of SiPMs (**FY23**)
- Exploratory investigations with MCP-PMT readout (FY23+)
- *Important for:* realistic waveform analysis and simulations, readout design optimization

Committee Questions



Argonne National Laboratory is a
U.S. Department of Energy laboratory
managed by UChicago Argonne, LLC.

MCP-PMT and LAPPD

1. Please discuss considerations of lifetime and magnetic field resistance for the alternative photosensors. For example:
 - a. How many Coulombs of charge are expected annually?
 - b. What will be the maximum transverse magnetic field this option can handle?

1 a) Yearly charge expected annually $< 1.38 \text{ C/cm}^2$

- signal and beam-gas background
see estimate in backup slides
- MCP PMT with Atomic Layer Deposition (ALD) coating show lifetime exceeding 10 C/cm^2 (even 26 C/cm^2)

1 b) Expected max fields for 1.7 T magnet map (EPIC)

- $B_r = -0.577 \text{ T}$, $B_z = -0.843 \text{ T}$
at $r = 118.00 \text{ cm}$, $z = 178.00 \text{ cm}$
- Small fields. The angle between the B field and the face of the sensor may be addressed in the barrel design

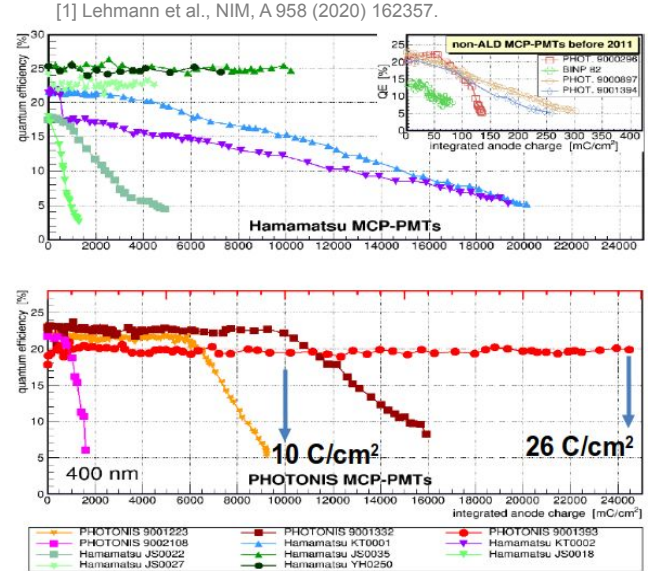

Fig. 1 . Results from the Lifetime testing conducted by Lehmann et al., NIMA (2020) [1]. The Quantum efficiency as a function of integrated anode charge for ALD coated MCP-PMTs. The inset in top panel for non-ALD MCP-PMTs.

Source: V. A. Chirayath, A. Brandt, LAPPD Workshop, 10/22

SciFi/Pb

2. In the scintillation fiber layers, to what extent would multi-cluster separation in the same azimuthal sector be possible, e.g. by using timing and digital layer matching? Does this complicate reconstruction of high local density measurements, such as in jet substructure?

- **Proposed Project Goal: collect realistic waveforms and including them in realistic simulations.**
- Currently considered granularity with $r = 80$ cm and lightguide width of 2 cm: **one sector covers $\Delta\phi = \sim 1.5$ deg**

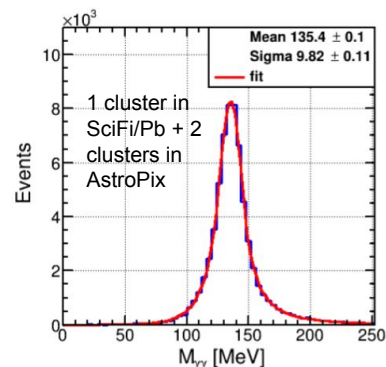
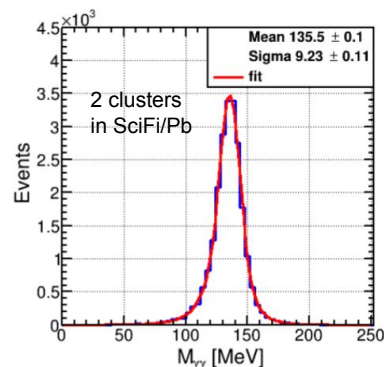
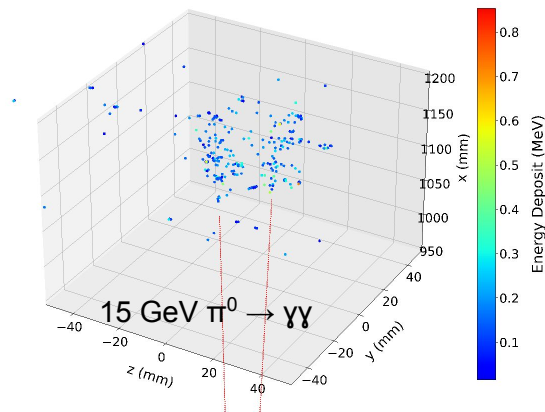

Example: 2 GeV π^0 invariant mass reconstruction

- **Position separation from AstroPix Layers** (~ 0.5 mm of impact point, precise shower profile imaging) and **SciFi timing information** ($\sim 1 \text{ cm}/\sqrt{E}$) even if 2 particles hit exactly the same $\Delta\phi = 1.5$ deg sector.
- **Energy separation** can be made to some extent with AstroPix layers (they are NOT digital, we have energy losses of every pixel). Energy resolution $\sim 30\%$

SciFi/Pb

2. In the scintillation fiber layers, to what extent would multi-cluster separation in the same azimuthal sector be possible, e.g. by using timing and digital layer matching? Does this complicate reconstruction of high local density measurements, such as in jet substructure?

- **Probability of 2 particles hit exactly the same $\Delta\phi = 1.5$ deg sector quite low.** For example:
 - 3% of all gamma pairs from SIDIS π^0 decays
 - For jets (anti-kT, R=1.0) >60% has more than 1 gamma, out of them ~ 17% fall within **3 sectors $\Delta\phi = 4.5$ deg**
- For the small fraction of events that end up in the same (or close) $\Delta\phi = 1.5$ deg sector, the rough separation based on the example waveforms seems to allow for separation ~50 cm
- Detailed analysis of specific physics aspects requires stimulation with realistic waveform analysis

SciFi/Pb

3. What is the light collection uniformity in the scintillation fiber layers? Does it lead to any position dependent energy uniformity and extra constant term in this proposed calorimeter?

Experience from GlueX: detailed studies performed in testing the light collection uniformity in the scintillating fibers.

- Naked fibres tested (random 0.5-1.0% sampling from each fiber shipment); **agreed** with Kuraray checks:
 - **Attenuation length** average **385 cm** (RMS = 7%)
 - **Npe** average **7.5** (RMS 8-10%) per fiber using 90Sr source
- Cosmics in prototype module (Pb/SciFi matrix) viewing 2x2cm² window (Winston Cone, calibrated PMT):
 - **Attenuation length** **320 cm** for PMTs, **436 cm** for SiPMs, **Npe** consistent with naked fiber tests

Up to 40% light loss due to the 0.5 mm air gap (versus silicon cookies or optical grease); tapered square profile light guides

Bootstrap π^0 gain calibration: E non-linearity correction works well, position dependence ~few % non-uniform due to bkgd under π^0

But! GlueX experience shows that nonuniformities are calibrated out - the system is forgiving. Dependencies of constant term will be investigated.

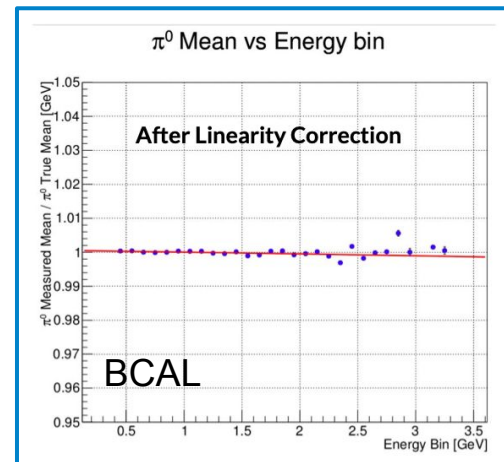

SciFi/Pb

4. How confident is the collaboration in the hadron rejection simulation? Is it possible to verify it with test beam data in FY23?

- **Simulations:**

- Realistic Pb/SciFi matrix implementation (SciFi, glue, cladding), digitization and reconstruction included
- FTFP_BERT physics list and 0.126 mm/MeV Birk's constant

- **The response to pions** in Barrel ECal changes slightly while changing the Birk's constant $\sim 38\%$.

- The e/π separation **bases heavily on imaging layers** response (topology of the shower)

- AstroPix beamtime starting Feb and May, 2023 at FNAL

Priority to run in Hall D before March 2023 (shutdown)

- Hall D support (prototype and DAQ/triggering exist)
- Test with existing prototype was done in Hall B (2012)

Challenges: Full independent setup required at FNAL + beamtime schedule very busy for FY23

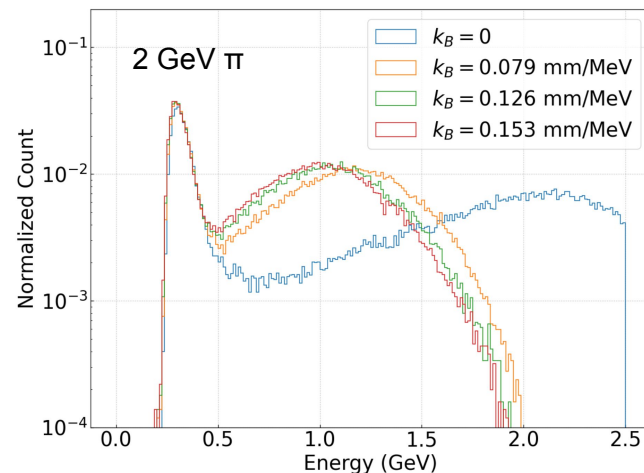

SciFi/Pb

8. Update the availability of VME readout boards.

Working with Hall D mechanical and electrical group leaders for tests in JLAB in FY23:

- VME boards and crate should be available for a test in Hall D
- Looking into whether SiPM HV and LV supplies are available; some procurement needed

AstroPix

5. Can you provide an update on NASA's plan to make AstroPix sensors commercially available?

AstroPix: a monolithic CMOS sensor and ASIC

- Developed by NASA Goddard, Argonne, and Karlsruhe after the ATLASPix chip designed at Karlsruhe.

R&D: ~2017-2020 (ATLASPix, MuPix, etc.)

Conceptual design: 2019-2020

First engineering run: AstroPix-v1 submitted in March 2020

Second version: AstroPix v2 submitted June 2021, characterization and testing, heavy-ion irradiation studies

Flight prototype: v3a submitted in June 2022, Fully functional chip

Integration with detector: start 2023 w/ v2/v3a, tracking implementation, test beams, irradiation studies

Integration with detector: v3b AstroPix late 2023, Sounding Rocket Payload (late 2024).

AMEGO-X prototype: 2025 onward

Version v3b available in 2024

AstroPix

6. Please summarize the prototyping and beam test plan with the Astropix sensor layers.

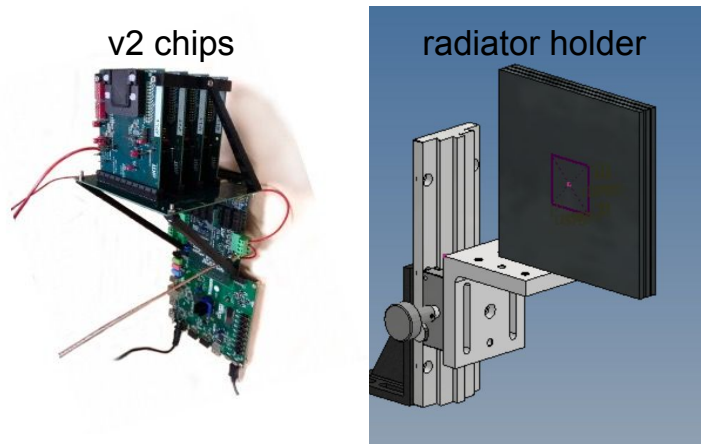

- Beam tests in February and May 2023
- 4 AstroPix chips will be read simultaneously in a tracker mode and calorimeter mode with W radiator

R&D program towards prototyping the generic imaging calorimetry for EIC in FY23

- Tests of **AstroPix v2/v3a sensor** in the EM calorimetry environment
 - **multilayer chip tests** in FNAL with protons, pions and electrons, tests with tungsten radiator, readout aspects (LDRD grant)
 - **irradiation test** in the FNAL ITA Facility (LDRD grant)
 - readout of multilayer chips with the FLX board (activities within the HEP/NASA community)

FY24 Plan

- Response to electromagnetic/hadronic shower with multilayer AstroPix v3b prototype

AstroPix

7. Please provide an outline of the readout for the Astropix sensor layers.

What is the expected zero-suppression energy threshold applied to the pixels:

- $4\sigma = 4 \times 5 \text{ keV}$ (noise of $\sim 225 \text{ e}^-$ with estimated 1pF pixel capacitance for v3a AstroPix)
- Tested both 4 and 6 sigma threshold in simulation and we haven't seen any significant impact on, for example, e/pi separation

What is the dark noise rate using that threshold?

- Dark noise on the level of 10^{-9}

What is the ADC bit precision and sampling speed? What is the timing precision?

- Sampling 200 MHz (v3)
- Timing $\sim 25 \text{ ns}$

AstroPix

7. Please provide an outline of the readout for the Astropix sensor layers.

What is the path for the signals from the Astropix chip to the DAQ?

- The single readout unit will be a $2 \times 2 \text{ cm}^2$ quad-chip with the pixel size of $500 \mu\text{m} \times 500 \mu\text{m}$
- The signals from each pixel will be digitized and passed through the daisy chain
- A threshold of about 4σ of the noise level will be set to suppress false signals
- The hit packet from each pixel: 5 bytes data (chip ID, pixel location, timing information, and two bytes for the ToT)
- Expected total power usage $< 4 \text{ kW}$ (without digital conversions) for the 6 AstroPix layers in the proposed calorimeter

The readout system will utilize a design of two-level aggregators.

- Each stage of the detector will be covered by **8 first-level aggregators**
 - Collect the signals from the covered area and send the data to the second-level aggregators.
- 2nd level aggregator: inject the AstroPix data into the main data stream.

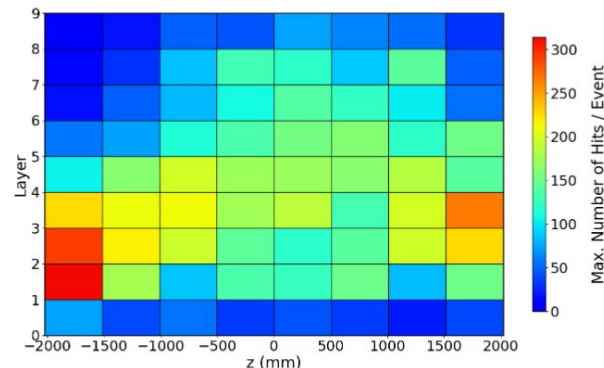

Backup



Argonne National Laboratory is a
U.S. Department of Energy laboratory
managed by UChicago Argonne, LLC.

Budget

Item	Units	Price per unit (USD)	Total price (USD)	Source of price estimate
VME crate	1	\$16,500	\$16,500	Old quote (2019)
Single board computer (SBC)	1	\$8,000	\$8,000	Old quote (2019)
PC	1	\$2,000	\$2,000	Current market prices (ANL provider website)
Rack-mountable server with fast hard drives	1	\$7,000	\$7,000	Current market prices (provider website)
FADC board (16 ch)	1	\$6,500	\$6,500	Old quote (2019)
TDC board (32 ch)	2	\$5,500	\$11,000	Old quote (2013) adjusted to 2022 USD
MPOD HV Module	1	\$9,000	\$9,000	Current Wiener quote
TI boards	1	\$6,000	\$6,000	Old quote (2019)
MCP-PMT readout PCB board	2	\$5,000	\$10,000	Expert opinion
Travel - ANL	5	\$2,000	\$10,000	Typical travel prices from ANL
Travel - Regina	2	\$4,500	\$9,000	Typical travel prices from Regina
Travel - Regina (from Pennsylvania)	1	\$2,000	\$2,000	Typical travel prices from Pennsylvania
TOTAL:			\$97,000	

	Argonne National Laboratory	University of Regina
Personnel	0	0
Hardware	\$76K	0
Expenses including travel	\$10K	\$11K
Sum:	\$86K	\$11K

- Nominal budget -20%: resign from the purchases related to the MCP-PMT program by about \$8K (hard drives (-\$7K), or SBC (-\$8K))
- Nominal budget -40%: PC (-\$2K) and VME Crate (-\$16.5K) (or TDCs and ADCs)

Total charge estimate

Detector occupancy studied with ATHENA geometry: https://wiki.bnl.gov/athena/index.php?title=Beam_backgrounds

- Signal (Pythia6) $Q^2 > 10^{-9}$ GeV²
- e-beam and p-beam gas effects

Total number of hits (hit fibers) per sec in the SciFi/Pb barrel estimated for ATHENA and weighted by the hit energy spectrum from the signal and background

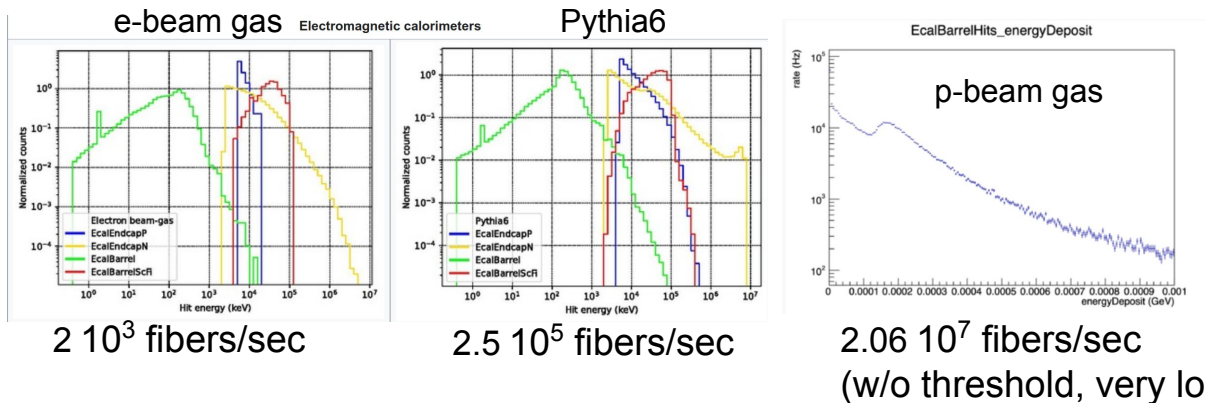

Energy weighted hits in the barrel scaled to hits/cm² by the area of SciFi/Pb one-side readout (26.24 10^3 cm²)

Total charge estimate

- Number of photoelectrons: ~ 7 Npe per naked fiber (measured with ^{90}Sr source, $E = 0.186$ MeV, GlueX)
- Assumed q.e.: $\sim 20\%$ (same for MCP-PMT and PMT from GlueX measurement)
- Gain for MCP-PMT = 10^6
- Assumed charge collection for every second in the year ($3.154 \cdot 10^7$ sec, conservative)
- Assumed 100% light collection efficiency (conservative)

Source	C/cm ² per year of constant running
Signal (Pythia6)	1.11E+00
e-beam gas	7.92E-03
p-beam gas	2.56E-01
	1.38E+00

Magnetic Field

1.7-T-Magnet field map at the edges of the calorimeter

$r = 80.00$ cm, $z = -258.00$ cm: $B_r = 0.193$ T, $B_z = -0.404$ T

$r = 80.00$ cm, $z = 178.00$ cm: $B_r = -0.323$ T, $B_z = -0.897$ T

$r = 118.00$ cm, $z = -258.00$ cm: $B_r = 0.269$ T, $B_z = -0.297$ T

$r = 118.00$ cm, $z = 178.00$ cm: $B_r = -0.577$ T, $B_z = -0.843$ T

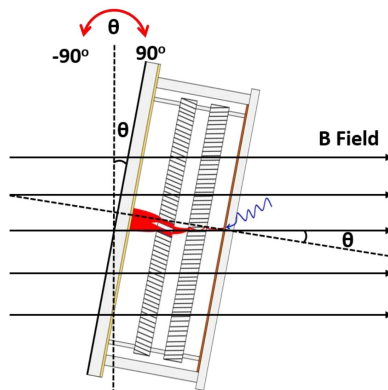
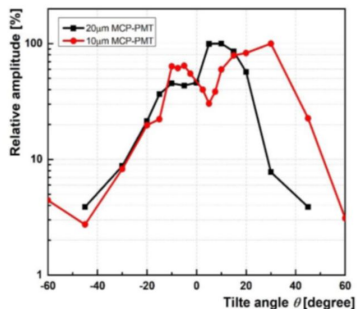
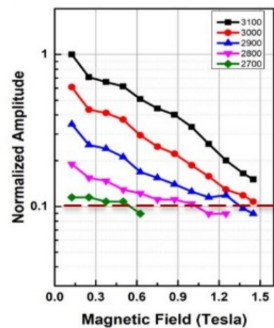
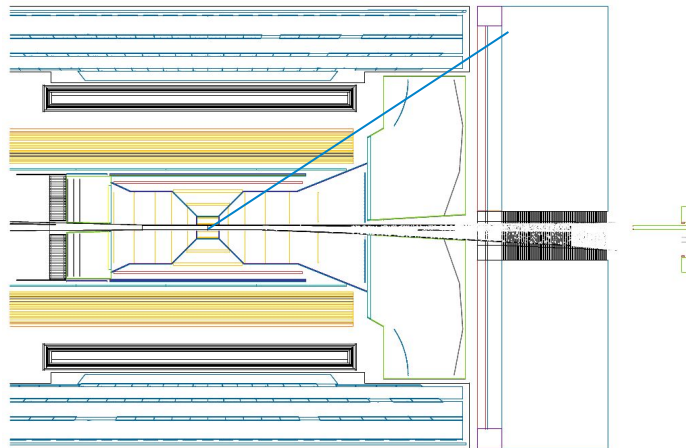

$0 < B < \text{at least } 1.5$ T

SciFi/Pb Calorimeter

Pb/ScFi layers follow the **GlueX Barrel Calorimeter** geometry

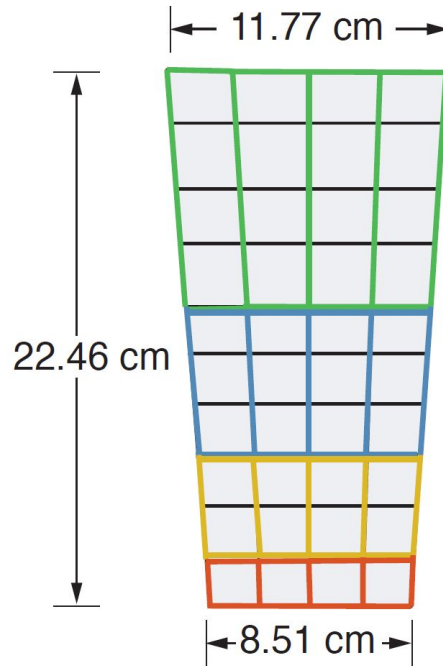
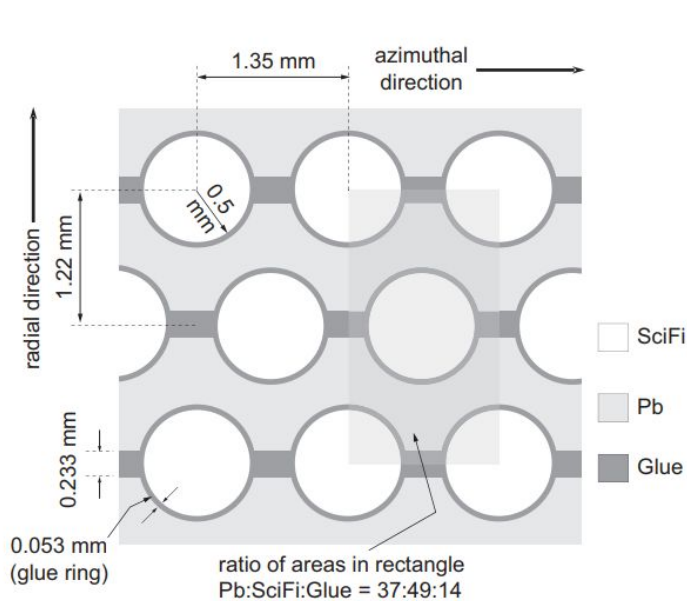

Simulation conditions

- Digitization in simulations on the level of SiPM grid
- Assumed ~ 2 cm x 2 cm grid size
- Possibility of 2-side readout (spatial resolution $\sim 1\text{cm}/\sqrt{E}$). In simulations only one side readout for island clustering
- Birks constant for ScFi $k_B = 0.126$ MeV/mm

In simulations ScFi and mixture of Pb and Glue

Imaging layers

Imaging layers based on AstroPix sensors - Developed for AmegoX NASA mission; successor of ATLASpix.

Simulation conditions:

- Digitization on the level of AstroPix pixel
- 4σ threshold cut applied
- No cracks/non-sensitive regions in the sensor coverage assumed in simulations
- Layer thickness 0.155 cm + 1 cm of air (cooling)

Layer material	Thickness (cm)
Silicon (sensors)	0.05
Silicon (electronics)	0.015
Copper (cables)	0.01
Kapton (insulation)	0.02
Epoxy (glue)	0.01
Carbon (support structure)	0.05

Advantages of AstroPix with respect to pixels used in e.g. ATLAS

- AstroPix has very low power consumption (used in space) - 1000 times smaller power consumption per cm^2 than ITk pixel
- AstroPix is a monolithic sensor - less complicated structure
- No bump bonding - less risk of damaging sensors

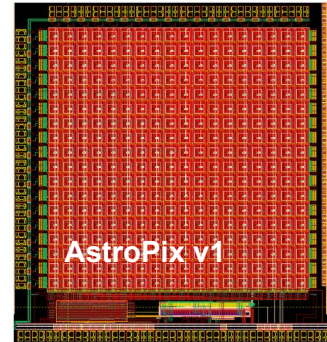

Pixel size	$0.5 \times 0.5 \text{ mm}^2$
Chip size	$1 \times 1 \text{ cm}^2$
Pixel matrix per chip	20×18
Power usage	1.44 mW/cm^2 + digital
Dynamic range	700 keV
Energy resolution	2% @ 662 keV
Time resolution	50 ns
Signal threshold	20 keV
Noise level	5 keV
Hit packet size	5 bytes

I. Brewer, et al., [arXiv:2101.02665](https://arxiv.org/abs/2101.02665) [astro-ph.IM]

Imaging Layers in Barrel ECAL

Excellent position resolution allowing precise 3D shower imaging

Significantly improved **electron/pion separation** with respect to E/p method

- Impact on DIS cross section and asymmetries

Separation of γ s from π^0 decays at high momenta up to ~ 40 GeV/c.

Precise position reconstruction of **γ s** (below 1 mm at 5 GeV).

- Impact on DVCS and photon physics

Provides a **space coordinate for DIRC** reconstruction (no need for additional large-radius tracking detector)

- Improving PID for SIDIS and beyond

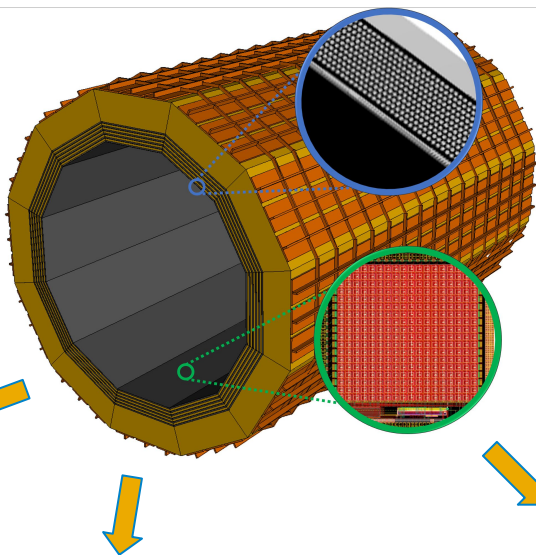

Precise measurement of **photon coordinates** and the **angle between electron and photon**

- Tagging **final state radiative photons** from nuclear/nucleon elastic scattering at low x to **benchmark QED internal corrections**

Allowing PID of **low energy muons** that curl inside the barrel ECAL

- $< \sim 1.5$ GeV/c with 3T field
- $< \sim 0.8$ GeV/c for 1.5T field
- Impact on J/psi reconstruction, TCS

Performance Study

Energy resolution from SciFi/Pb layers

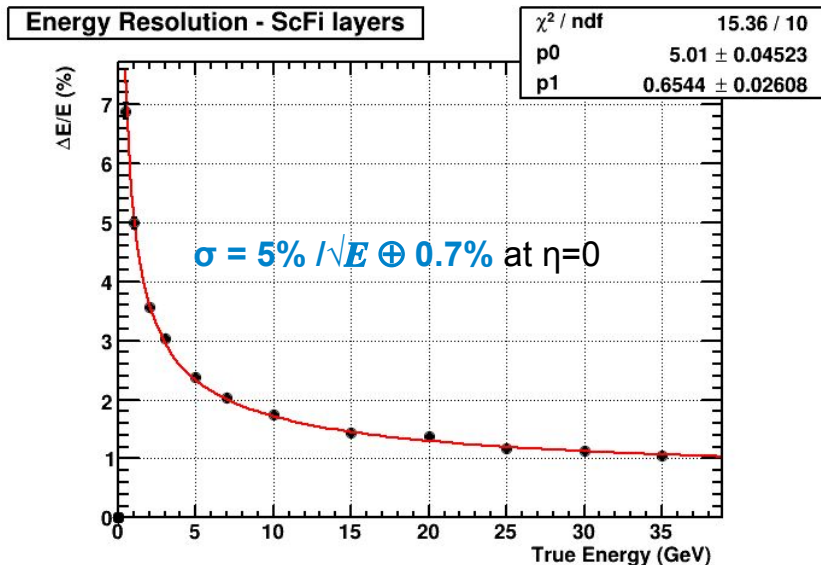

GlueX SciFi/Pb ECal

(15.5 X_0 , extracted for low energy photons $< \sim 1$ GeV)

$\sigma = 5.2\% / \sqrt{E} \oplus 3.6\%$ (NIM, A 896 (2018) 24-42)

Simulations of **single photons** at $\eta=0$ ($\sim 21 X_0$)

- **Realistic implementation of SciFi/Pb matrix** with glue and 4-mm double-cladding (like in GlueX)
- Energy resolution takes into account **realistic signal digitization and reconstruction**

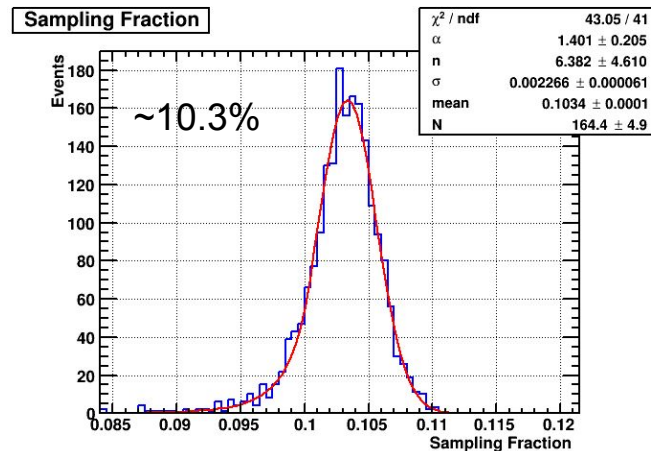

$$\text{Sampling fraction} = \frac{\sum E_{\text{fibers}}}{E_{\text{thrown}}}$$

GlueX Energy Resolution

The resolution $5.2\%/\sqrt{E} \oplus 3.6\%$ in GlueX: Integrated over typical angular distributions for π^0 and η production. Energies: 0.5-2.5 GeV.

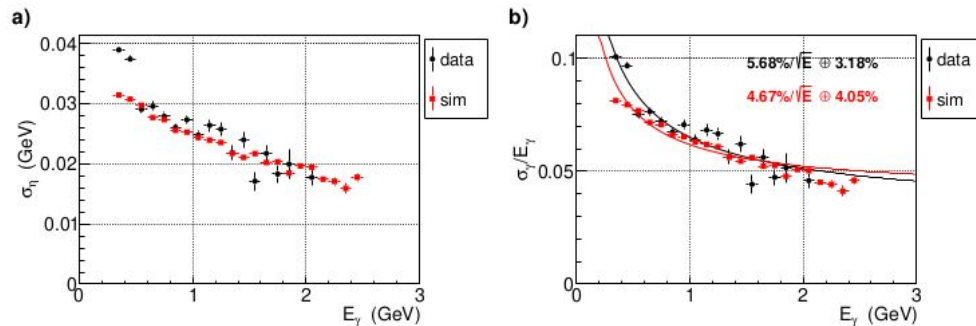

We note that the response of the calorimeter averaged over its length, as done for the η sample in Fig. 32, is not described well with Eq. 4 and **has a large correlation between the two parameters (-0.89)**. Nevertheless, in order to characterize the performance of the BCAL between 0.5 and 2.5 GeV, we take the fitted energy-resolution parameters integrated over the angular distributions for π^0 and η production to obtain a typical energy resolution for our detector of $5.2\%/\sqrt{E} \oplus 3.6\%$. In order to estimate the resolution at high energy, we use the MC that describes our data at low energy (Fig. 33) and results in a constant term of **less than 1.7%**. However, to verify this expectation, we would need additional data reaching to higher energy.

GlueX Energy resolution

GlueX Calorimeter is $15.5 X_0$ thick at normal angle

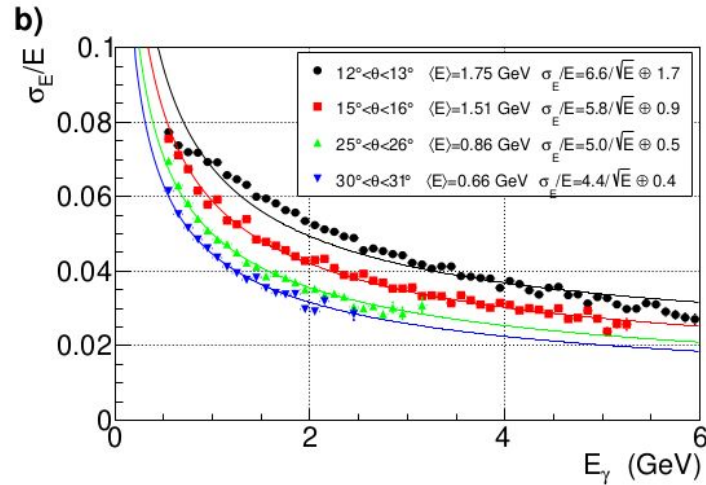

Performance Study

Position resolution from imaging layers

Example of $\theta - \phi$ resolution for 5 GeV photons

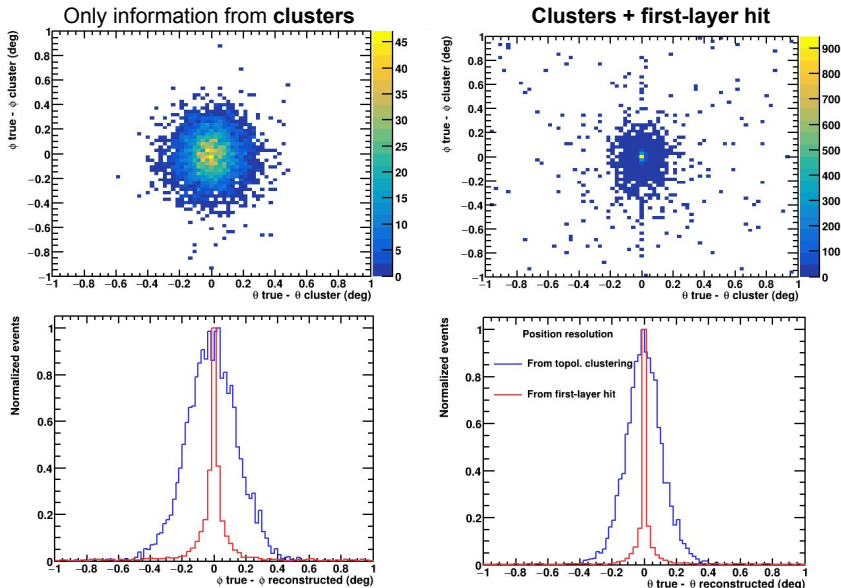

Position resolution for photons

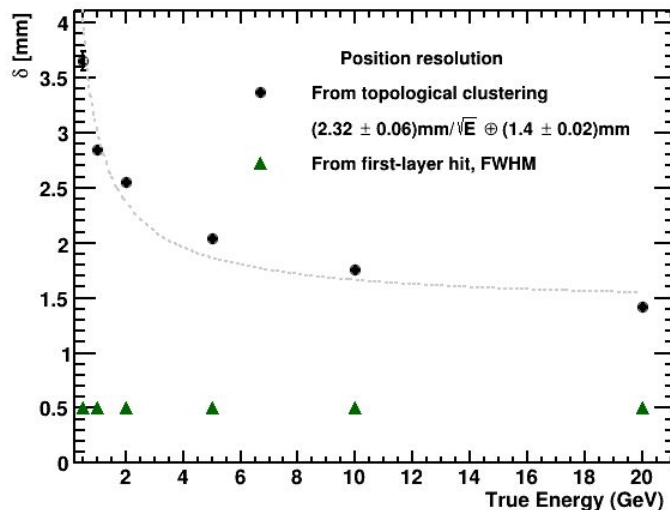

- Clusters from Imaging Si layers reconstructed with 3D topological algorithm
- **Cluster level information:** $\sigma_{\text{position}} = (2.32 \pm 0.06)\text{mm}/\sqrt{E} \oplus (1.4 \pm 0.02)\text{mm}$ at $\eta=0$
- **First-layer hit information added:** $\sigma_{\text{position}} = \sim 0.5\text{mm}$ (pixel size)

Performance Study

Electron Identification

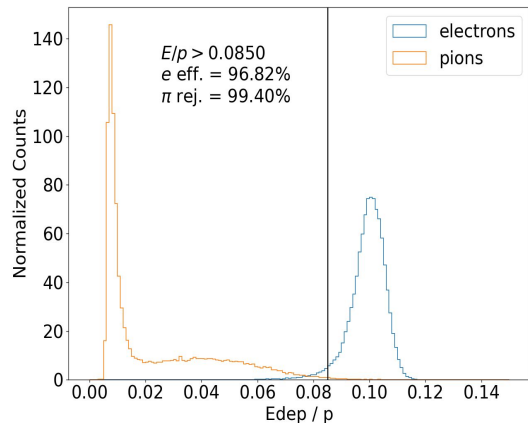

Initial cut on E/p from SciFi/Pb layers for e - π separation

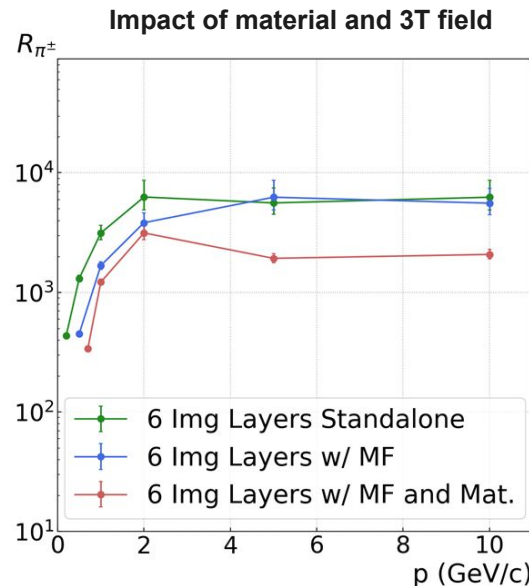
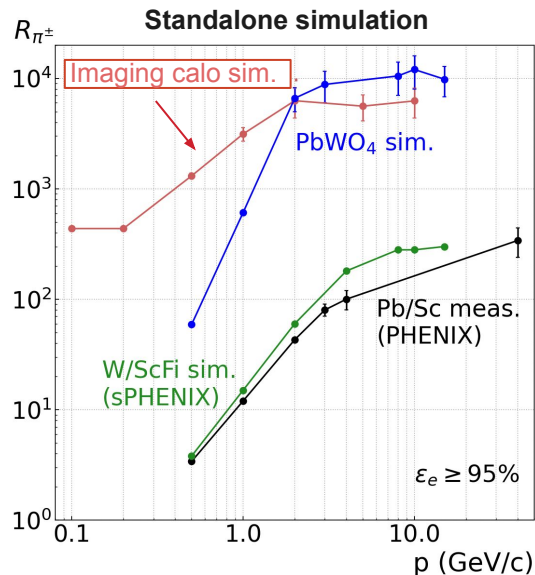

- **Goal:** Separation of electrons from background in Deep Inelastic Scattering (DIS) processes
- Method: E/p cut (SciFi) + Neural Network using 3D position and energy information from imaging layers

Electron-pion separation up to 10^4 in pion suppression at low particle-momenta

Performance Study

Neutral pion identification

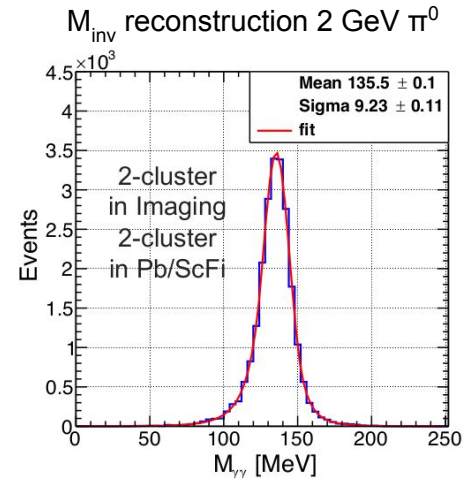
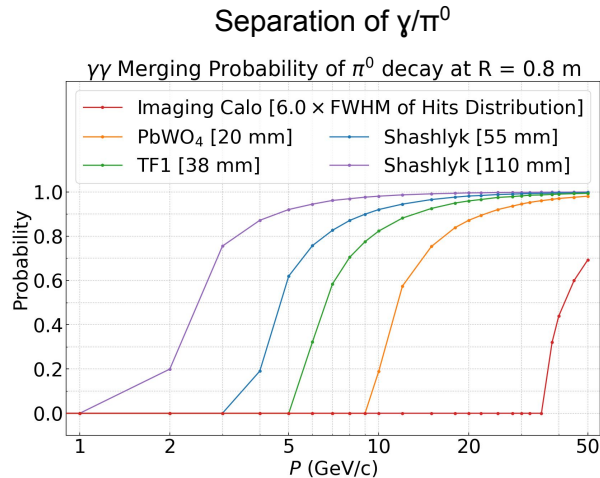
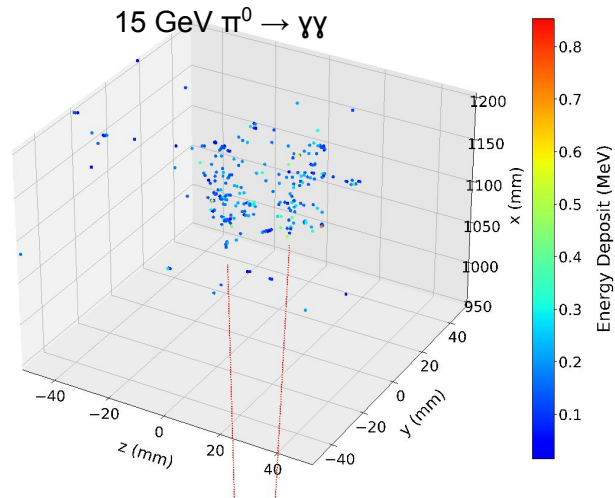

- **Goal:** Discriminate between π^0 decays and single γ from Deeply Virtual Compton Scattering (DVCS)
- Precise position resolution allow for excellent separation of γ/π^0 based on the 3D shower profile

Separation of two gammas from neutral pion well above 30 GeV

Performance Study

Muon identification

Muon-pion separation in **central region** uses information from the **electromagnetic (ECal) and hadronic (HCal) calorimeters**

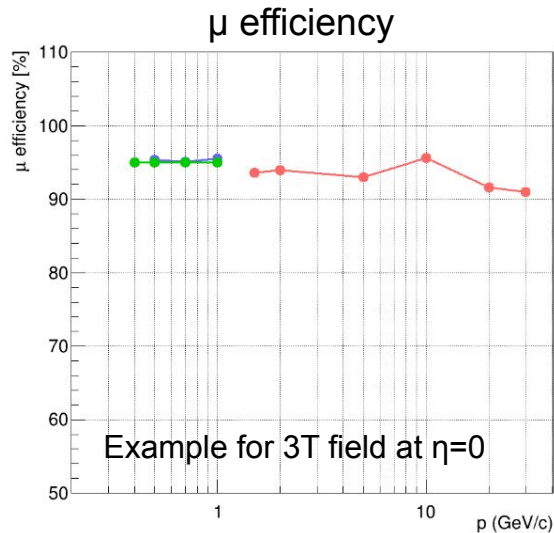
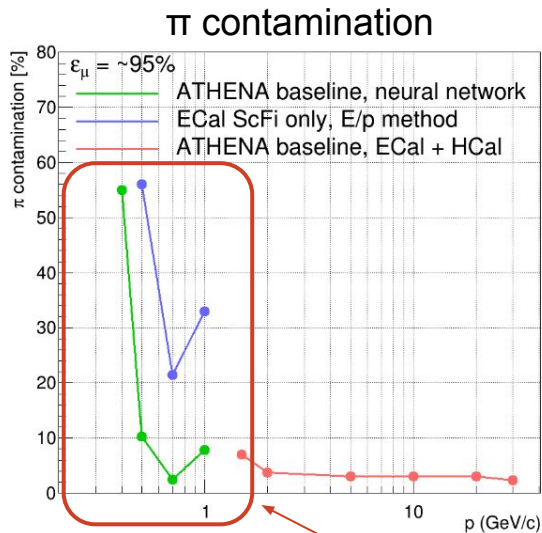

Low energy muons curl inside the barrel EM calorimeter

- $< \sim 1.5$ GeV/c with 3T field (shown in the plots)
- $< \sim 0.8$ GeV/c for 1.5T field

The discontinuity in reaching HCal is rapidity dependent

- Incorporating imaging layer information into **Neural Network** studies significantly improved the μ - π separation at low energies wrt **E/p studies from ECal only**
- Pion contamination for particles that reach HCal - **ECal+HCal studies**: below 5%

Pion Contamination in Inclusive DIS Physics

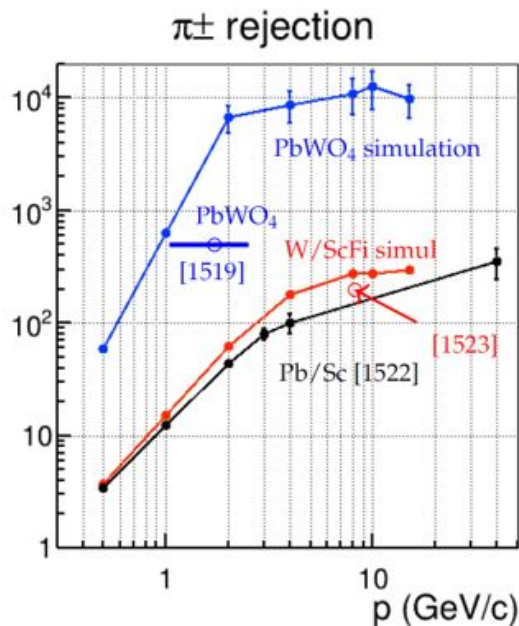

pion:electron > $10^3:1$ for $p < 2$ GeV/c in barrel
 No existing calorimetry fully satisfy the requirement

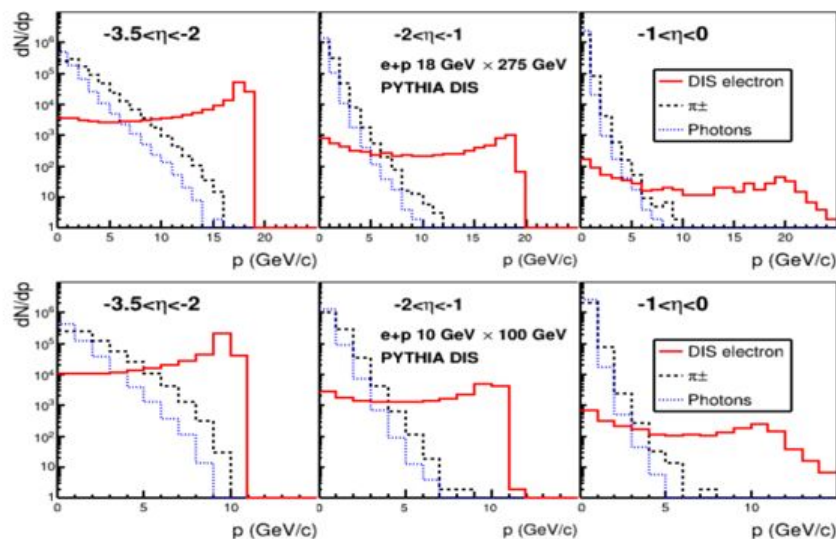

EIC Yellow Report, arXiv:2103.05419 [physics.ins-det]