

CNN-GAN for Physical Event Generation

Y. Alanazi

Advisor: Y. Li

Old Dominion University

Collaborators:

Jefferson Lab: N. Sato, T. Liu, W. Melnitchouk, E. McClellan

Davidson College: R. Ramanujan, M. Kuchera, E. Pritchard

University of Dallas: L. Velasco

➤ Outline

- Extended Features in FAT-GAN
- Can we leave it all up to the model to figure it out?
- Convolutional Neural Networks (CNN)
- Features Permutations
- Results

➤ Extended Features in FAT-GAN

- Feature engineering for our current **FAT-GAN**
- For example, pxy, pxz, pyz, pt, pzt
- Can the model detect these and other hidden features?
- CNN

➤ CNN

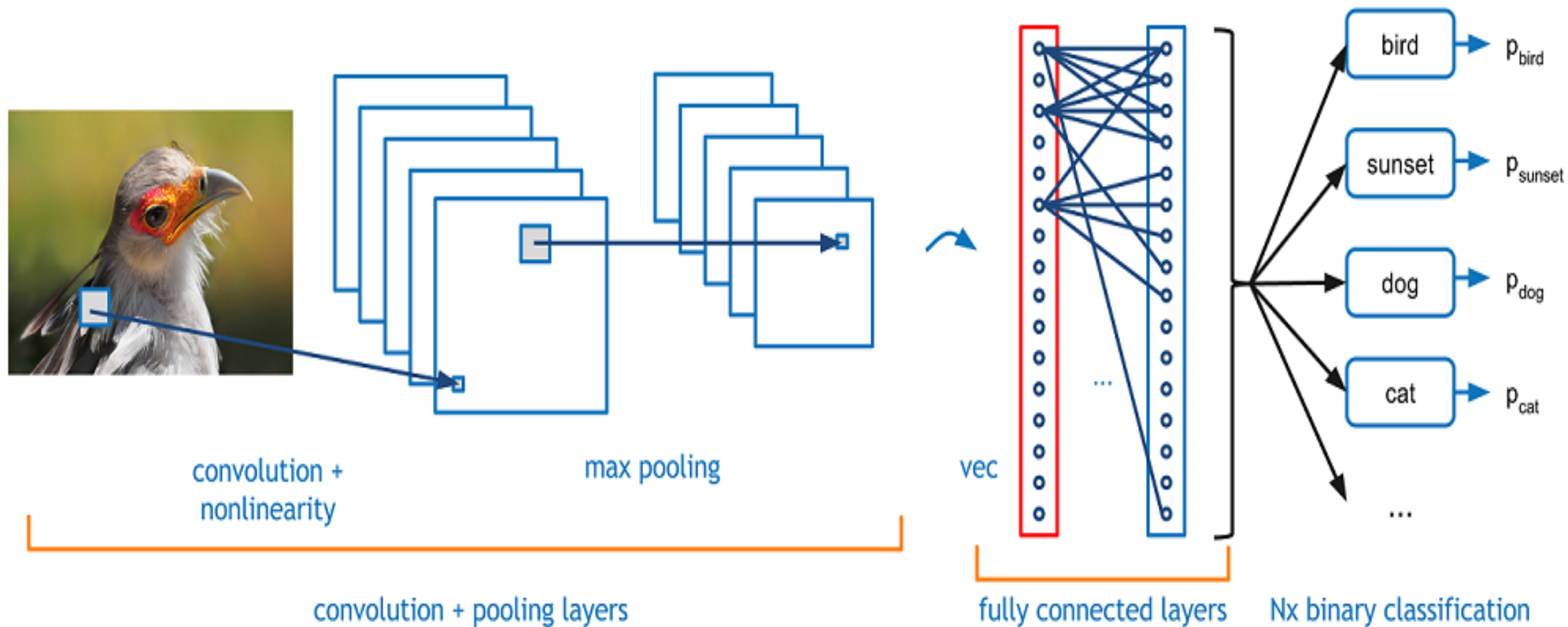

➤ Convolutional operation

4	9	8	7	5	2
2	6	7	7	6	1
1	3	5	2	2	6
1	2	1	3	4	3
3	3	2	8	7	6
4	1	6	7	8	8

Input data, 6x6

*

1	0	1
0	1	0
1	0	1

Filter

=

Feature map

➤ Convolutional operation

4	9	8	7	5	2
2	6	7	7	6	1
1	3	5	2	2	6
1	2	1	3	4	3
3	3	2	8	7	6
4	1	6	7	8	8

Input data, 6x6

*

1	0	1
0	1	0
1	0	1

Filter

=

24			

Feature map

➤ Convolutional operation

4	9	8	7	5	2
2	6	7	7	6	1
1	3	5	2	2	6
1	2	1	3	4	3
3	3	2	8	7	6
4	1	6	7	8	8

Input data, 6x6

*

1	0	1
0	1	0
1	0	1

Filter

=

24	28		

Feature map

➤ Convolutional operation

4	9	8	7	5	2
2	6	7	7	6	1
1	3	5	2	2	6
1	2	1	3	4	3
3	3	2	8	7	6
4	1	6	7	8	8

Input data, 6x6

*

1	0	1
0	1	0
1	0	1

Filter

=

24	28	27	

Feature map

➤ Convolutional operation

4	9	8	7	5	2
2	6	7	7	6	1
1	3	5	2	2	6
1	2	1	3	4	3
3	3	2	8	7	6
4	1	6	7	8	8

Input data, 6x6

*

1	0	1
0	1	0
1	0	1

Filter

=

24	28	27	23

Feature map

➤ Convolutional operation

4	9	8	7	5	2
2	6	7	7	6	1
1	3	5	2	2	6
1	2	1	3	4	3
3	3	2	8	7	6
4	1	6	7	8	8

Input data, 6x6

*

1	0	1
0	1	0
1	0	1

Filter

=

24	28	27	23
14			

Feature map

➤ Convolutional operation

4	9	8	7	5	2
2	6	7	7	6	1
1	3	5	2	2	6
1	2	1	3	4	3
3	3	2	8	7	6
4	1	6	7	8	8

Input data, 6x6

*

1	0	1
0	1	0
1	0	1

Filter

=

24	28	27	23
14	22	20	16
13	17	19	26
15	15	27	28

Feature map

➤ 1D CNN on the input vector

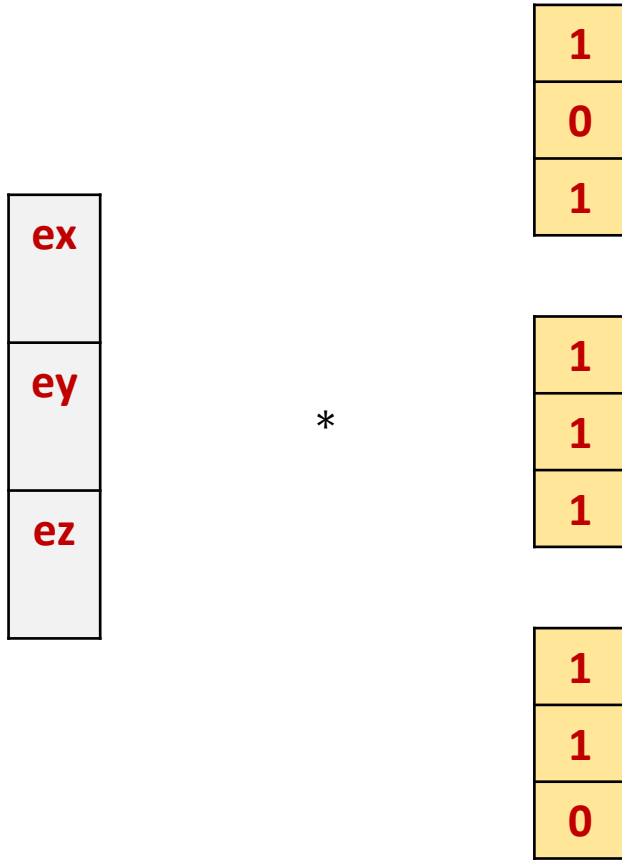

Input vector 3-momentum

Filter size = 3
of filters = 3

➤ 1D CNN on the input vector

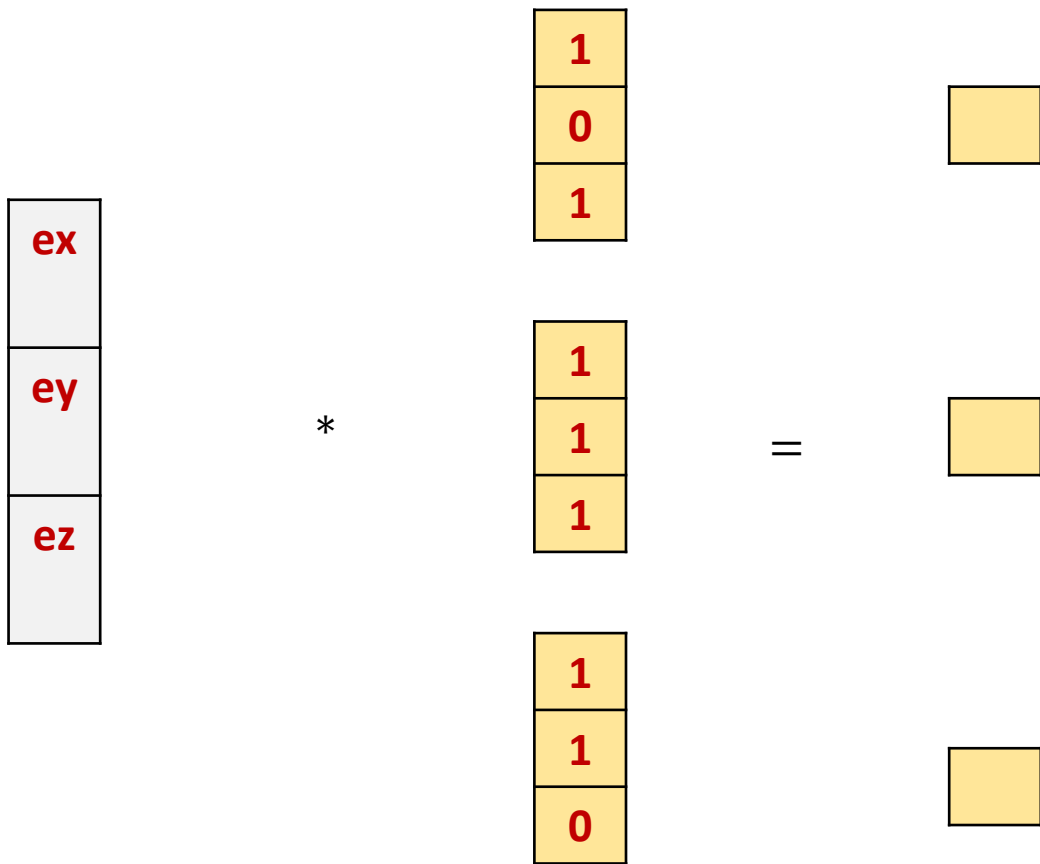

Input vector 3-momentum

Filter size = 3
of filters = 3

➤ 1D CNN on the input vector

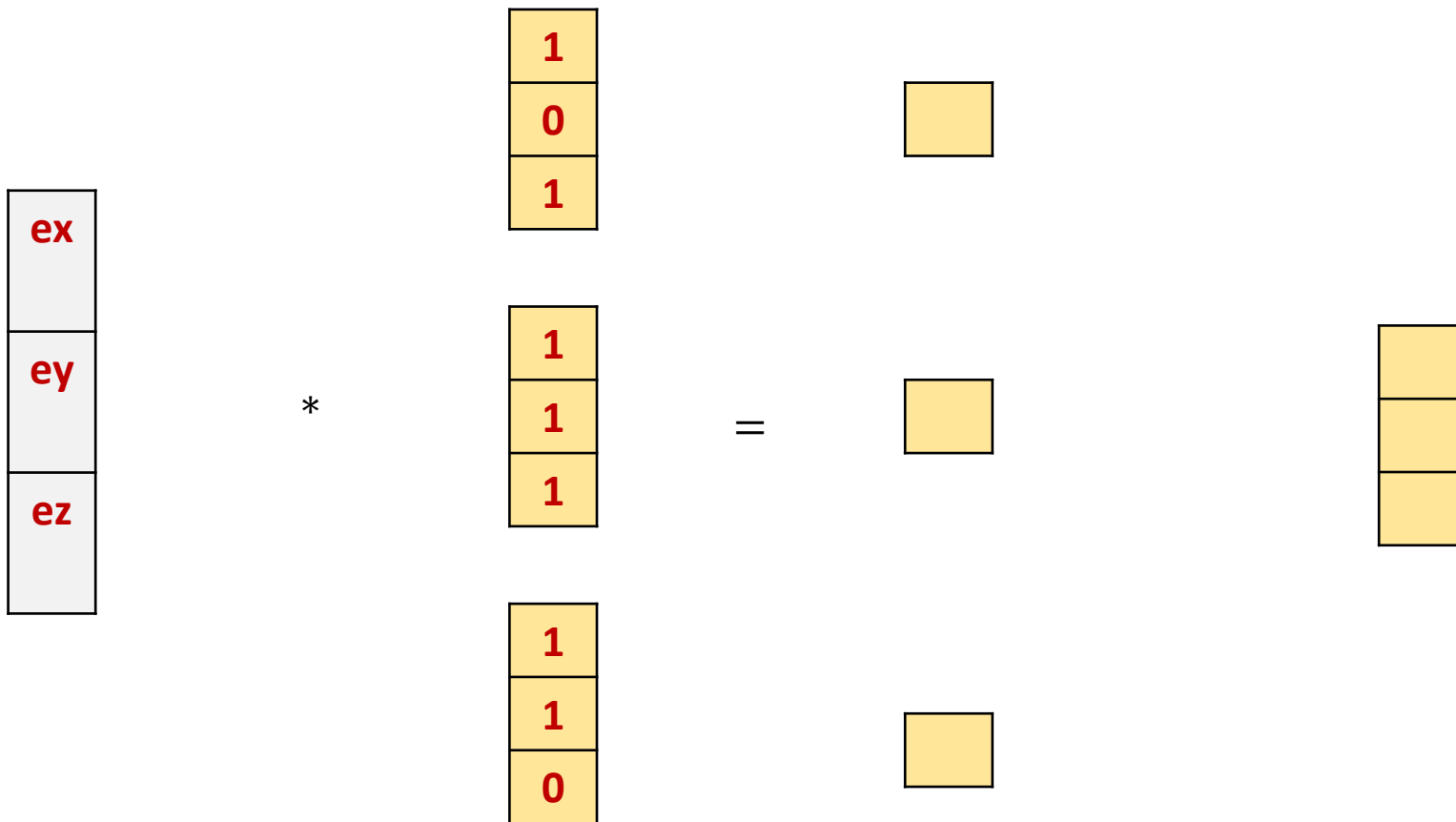

Input vector 3-momentum

Filter size = 3
of filters = 3

Results

Feature map

Feature permutations:

ex
ey
ez

*

1
0
1

Feature permutations:

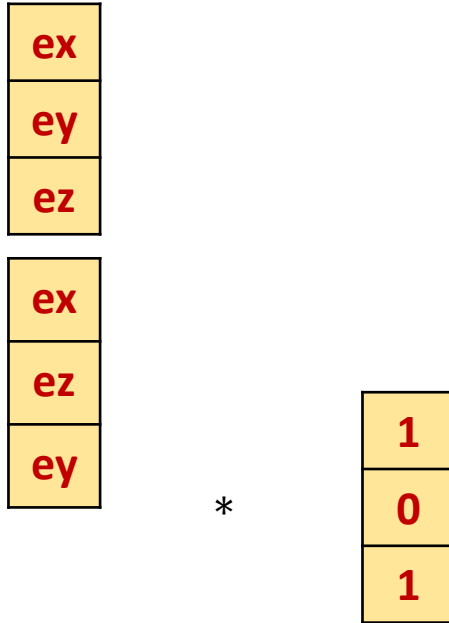

Feature permutations:

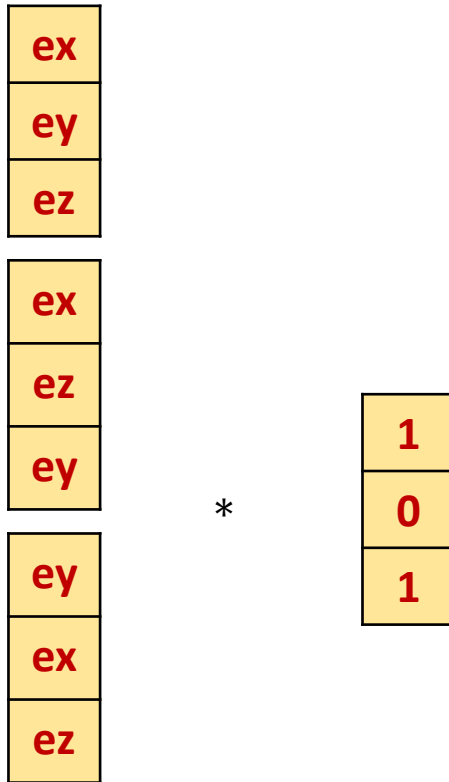

Feature permutations:

ex
ey
ez

ex
ez
ey

ey
ex
ez

ey
ez
ey

*

1
0
1

Feature permutations:

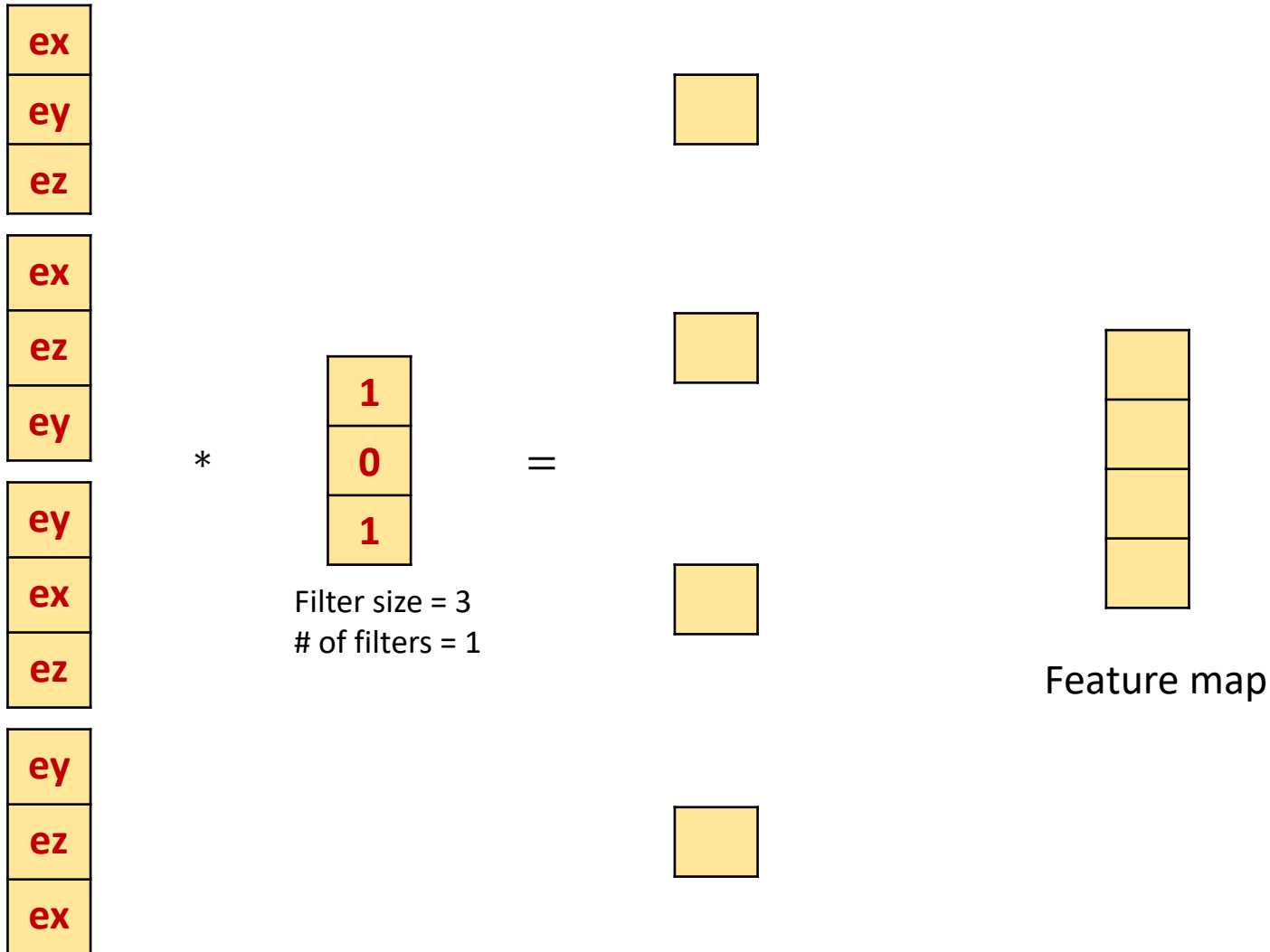

➤ Electron

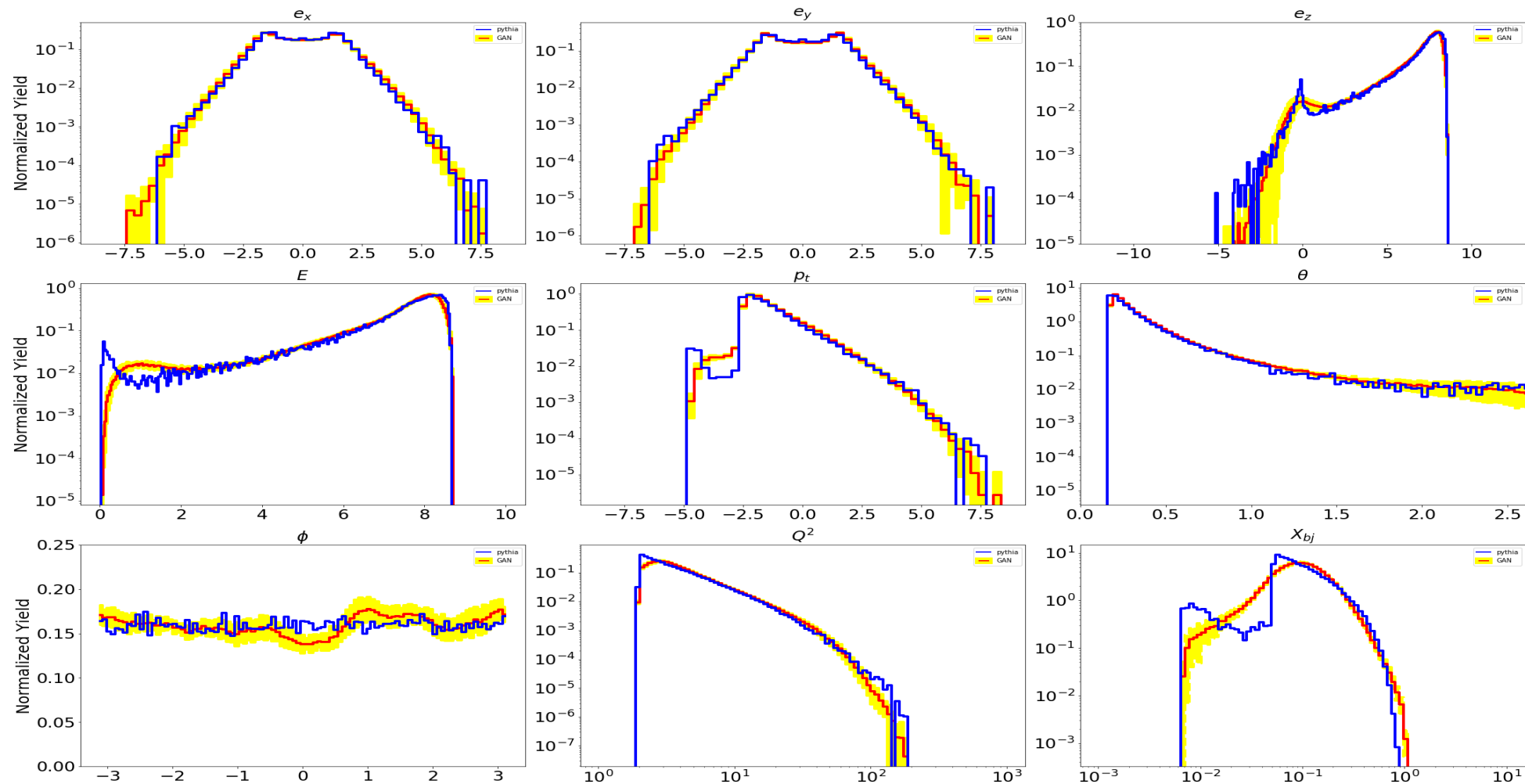

➤ Pion

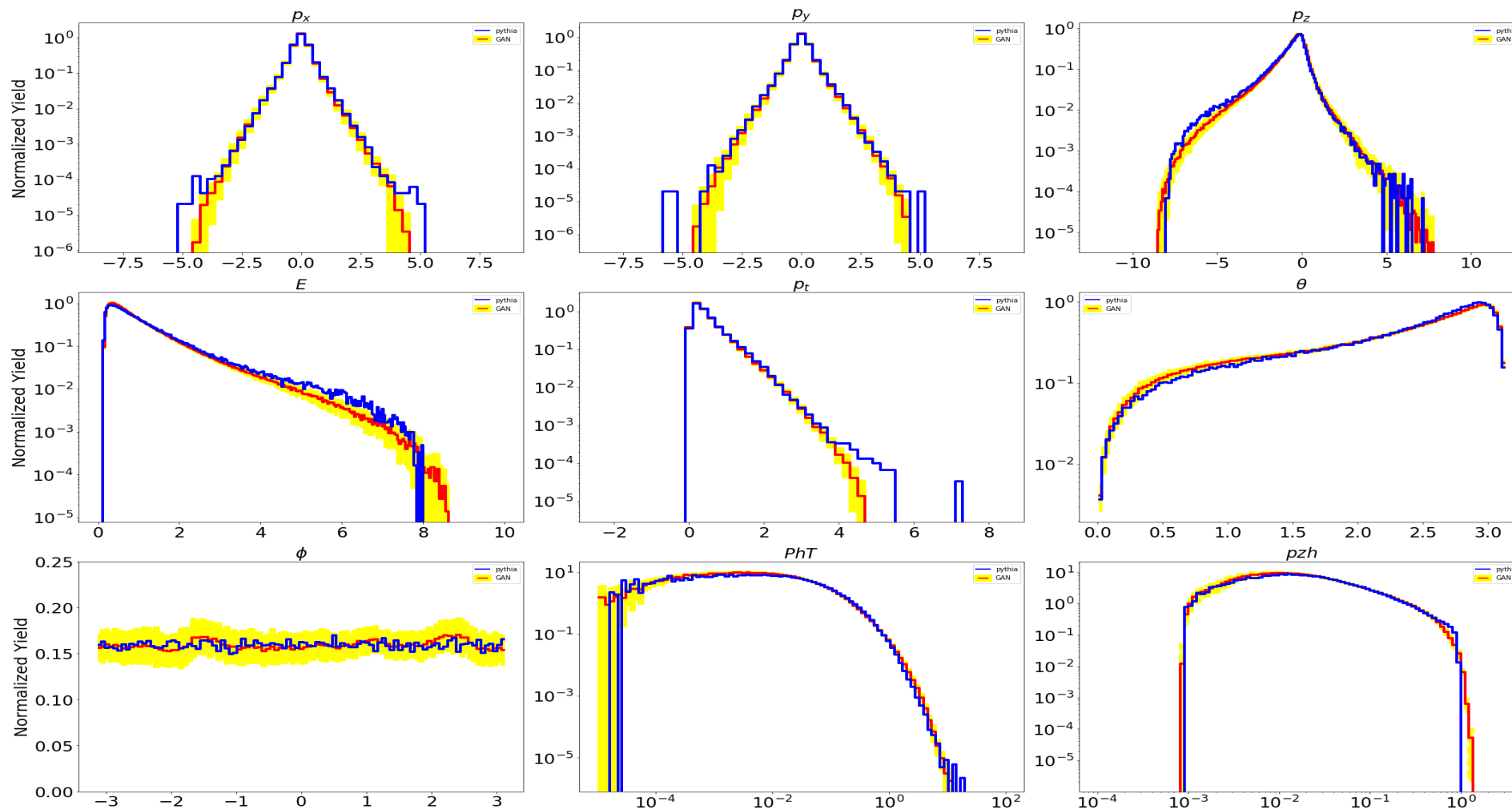

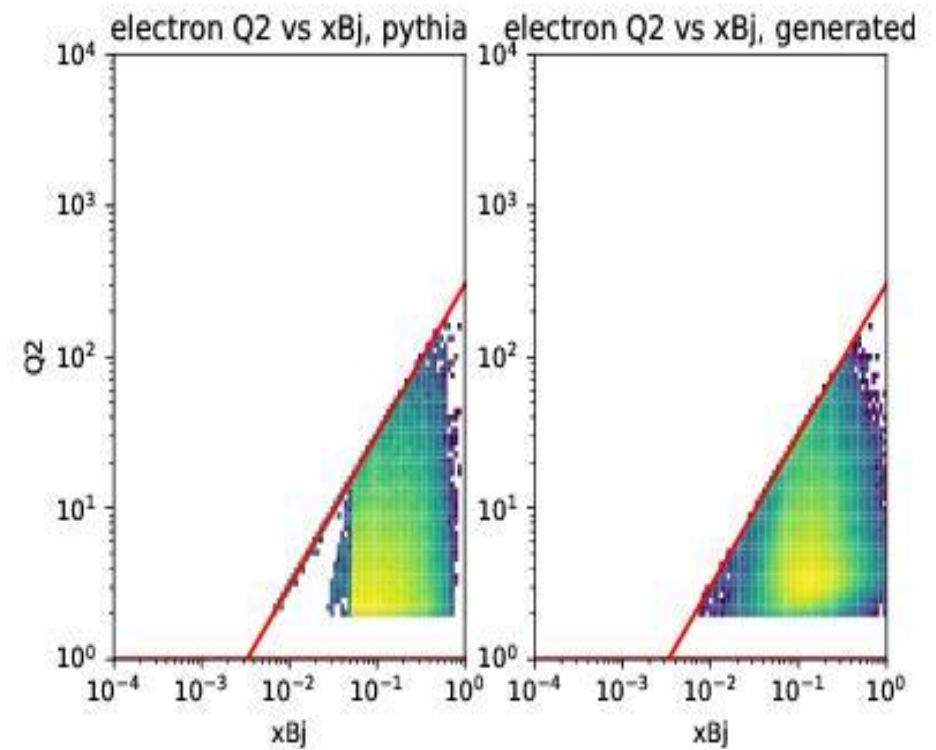
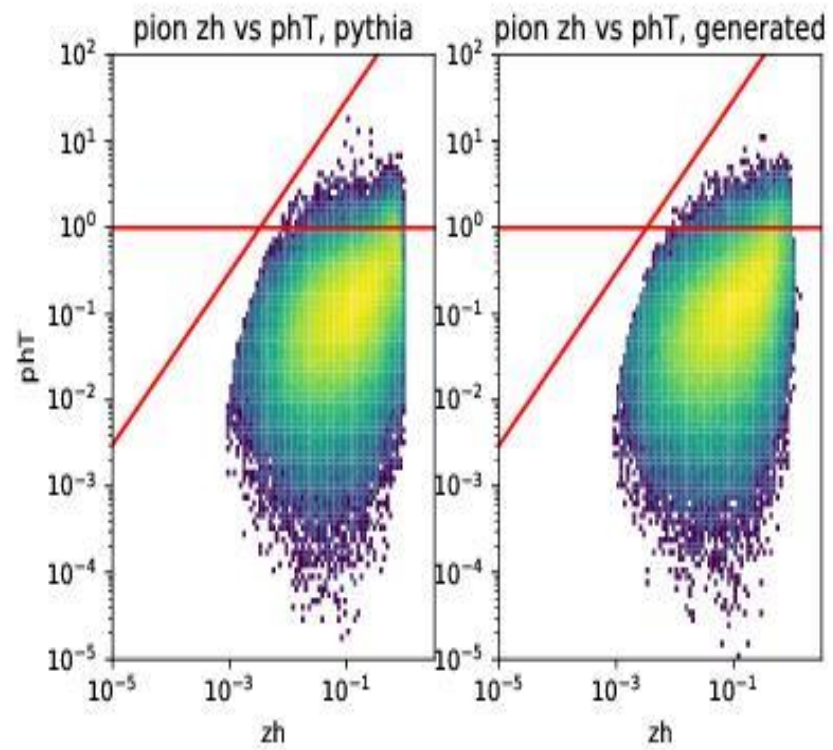

Thank you

CNN