

4

3

2

1

TOP VIEW

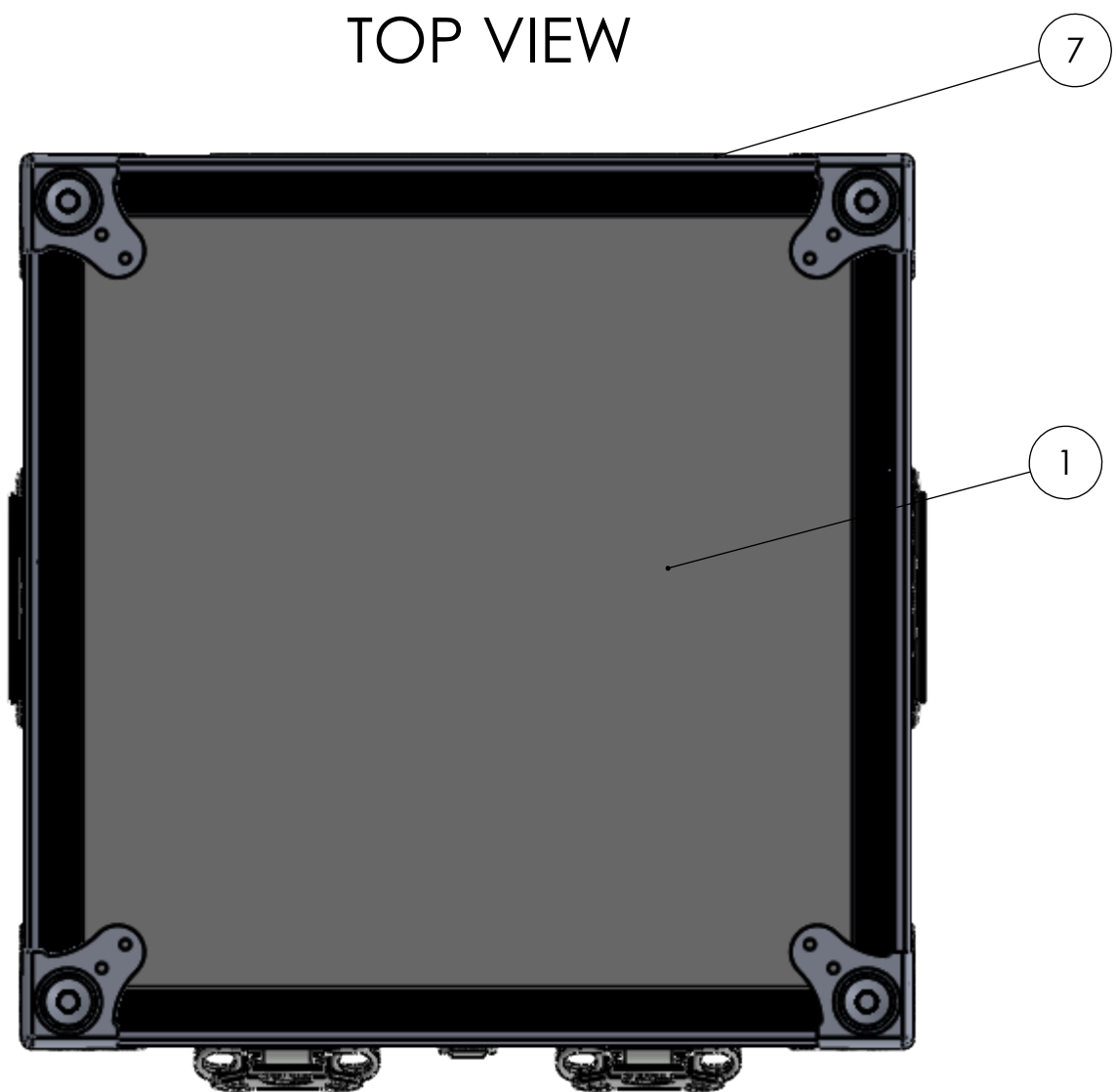

FRONT VIEW

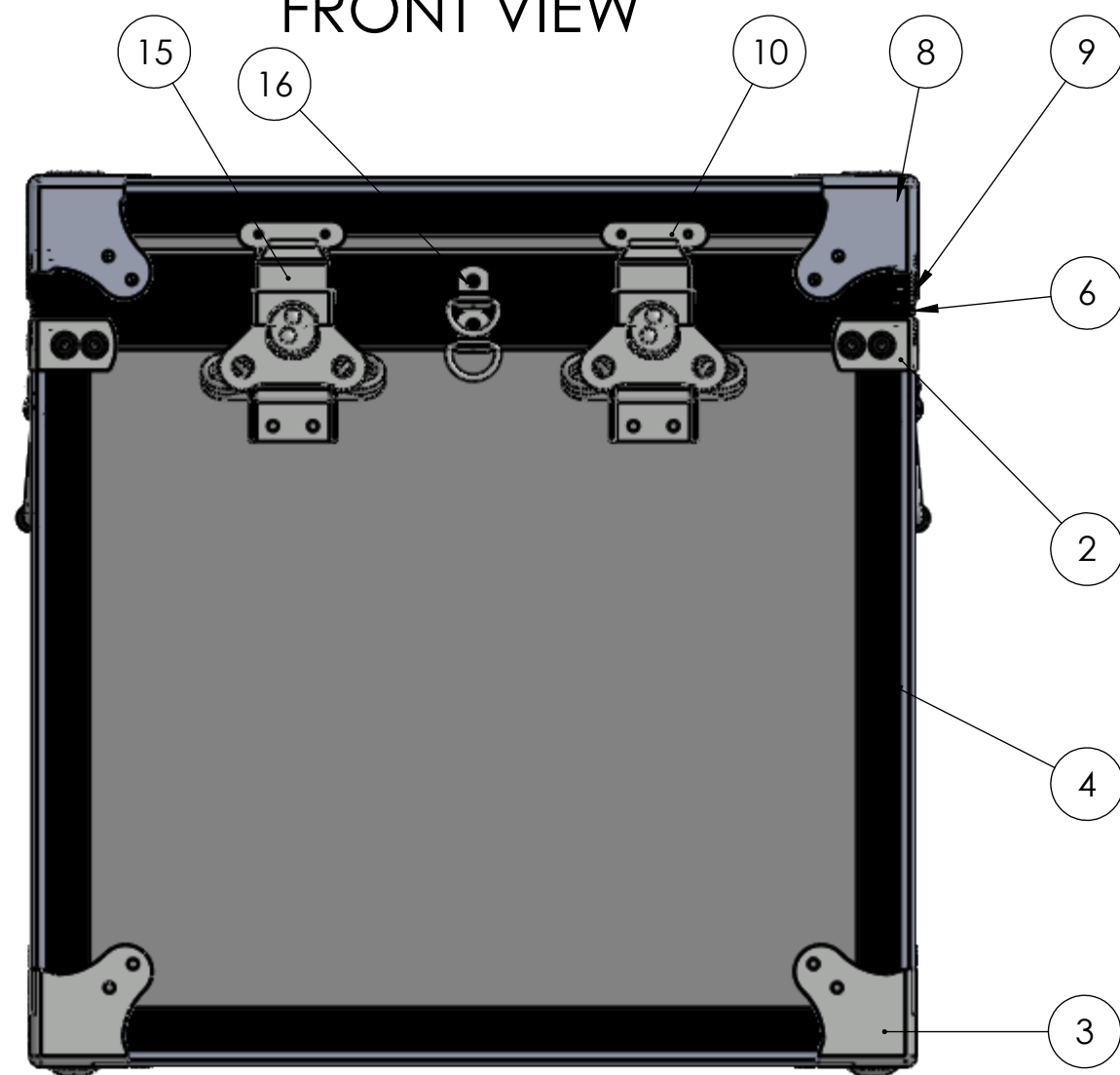

RIGHT VIEW

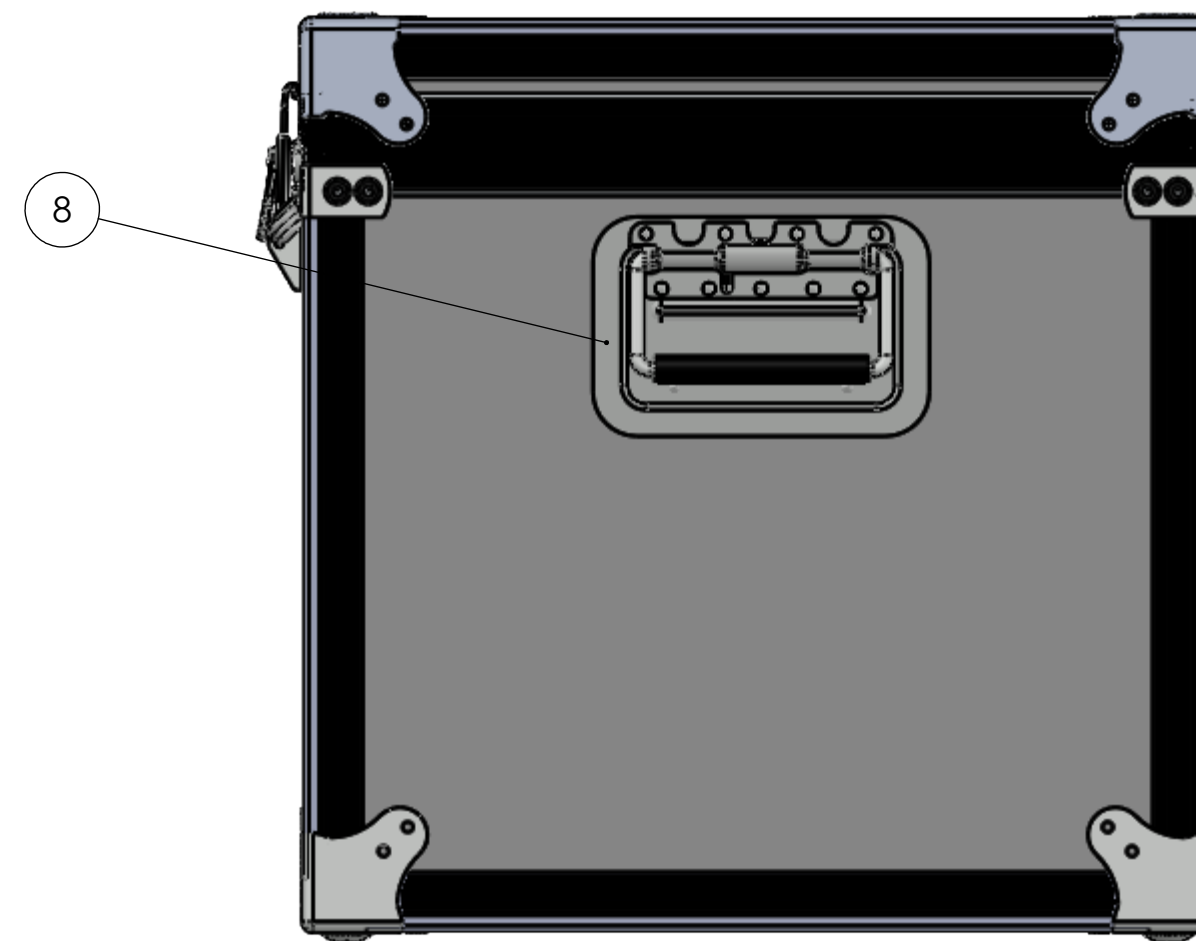

ITEM NO.	PART NUMBER	DESCRIPTION	QTY.
1	CASE PLASTIC/ MFG. FORMFLEX	3/16" HDPE PLASTIC	2
2	CORNER CLAMP/ MFG. PENN ELCOM P/N: 1703	STEEL CORNERS	4
3	BOTTOM BALL CORNER MFG. PENN ELCOM P/N: C1384Z	STEEL BOTTOM CORNER WITH DIMPLES FOR STACKING	4
4	ALUMINUM ANGLE/ MFG. EXTRUSION INC. P/N 7136	6063-T5 OR BETTER	4
5	RECESSED HANDLE WITH 3/4" RUBBER GRIP / MFG. PENN ELCOM P/N: 1818PBVPS UNM	SPRING LOADED HANDLES WITH 3/4" RUBBER GRIP	2
6	TONGUE EXTRUSION/ MFG EXTRUSION INC. P/N 7134	3/16" ALUMINUM EDGING	4
7	PIANO HINGE BOTTOM/ MFG. ALL-PRO FASTENERS	STAINLESS STEEL 9 5/8" PIANO STYLE HINGE	1
8	SHORT TOP CORNER/ MFG PENN ELCOM P/N: C1384Z	STEEL TOP CORNER WITH DIMPLES FOR STACKING	4
9	3/16" GROOVE EXTRUSION/ MFG. EXTRUSION INC. P/N 7135	3/16" ALUMINUM EDGING	4
10	KEEPER/ MFG. PENN ELCOM P/N: 0334	STEEL TWIST CATCH	2
11	INSULATION BOARD/ MFG. CELLOFOAM BSP1SC1S REFERENCE NO. ASTM-C578	1/2" INSULATON BOARD	10
12	CANVAS INSERT/ MFG. TRI VANTAGE P/N: 616060	70# POLYURETHANE FOAM AND CHIP BOARD WRAPPED IN CANVAS	6
13	FOAM CAP	1.7# WHITE HDPE FOAM	2
14	5 LITER CAN/VPS-M-005	ALUMINUM 5 LITER CAN	1
15	SURFACE MOUNT TWIST LATCH/ MFG. PENN ELCOM P/N 7460	MED TWIST LATCH	2
16	D-RING	TAMPER PROOF SEAL 6063-T5 OR BETTER	2

CUSTOMER APPROVED



**PROPRIETARY AND CONFIDENTIAL**  
 THE INFORMATION CONTAINED IN THIS DRAWING IS THE SOLE PROPERTY OF VIKING PACKING. ANY REPRODUCTION IN PART OR AS A WHOLE WITHOUT THE WRITTEN PERMISSION OF VIKING PACKING IS PROHIBITED.

**UNLESS OTHERWISE SPECIFIED:**  
 DIMENSIONS ARE IN INCHES  
 TOLERANCES:  
 FRACTIONAL ± 1/8"  
 ANGULAR: MACH ± BEND ± TWO PLACE DECIMAL ± THREE PLACE DECIMAL ± .125"

DRAWN	KCS	10/19/16
CHECKED	JL	10/19/16
ENG APPR.		
MFG APPR.		
Q.A.		
COMMENTS:		

TITLE: VPSBXKT-001C		
VIKING		
SIZE C	DWG. NO. 001	REV 0
SCALE: 1:5	WEIGHT:	SHEET 1 OF 2

4

3

2

1

D

D

C

C

B

B

A

A

4

3

2

1

SECTION A-A  
SCALE 1 : 4

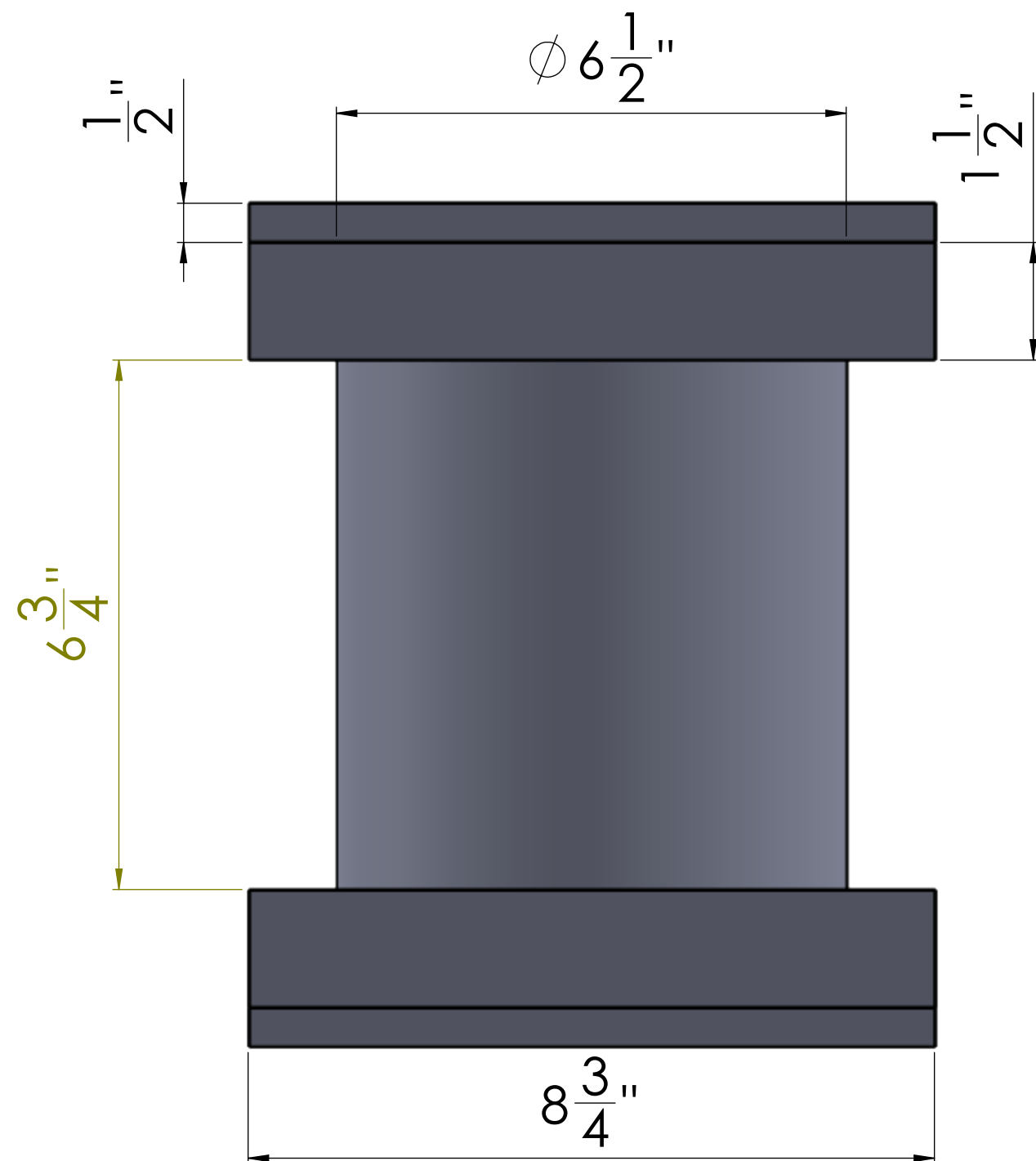
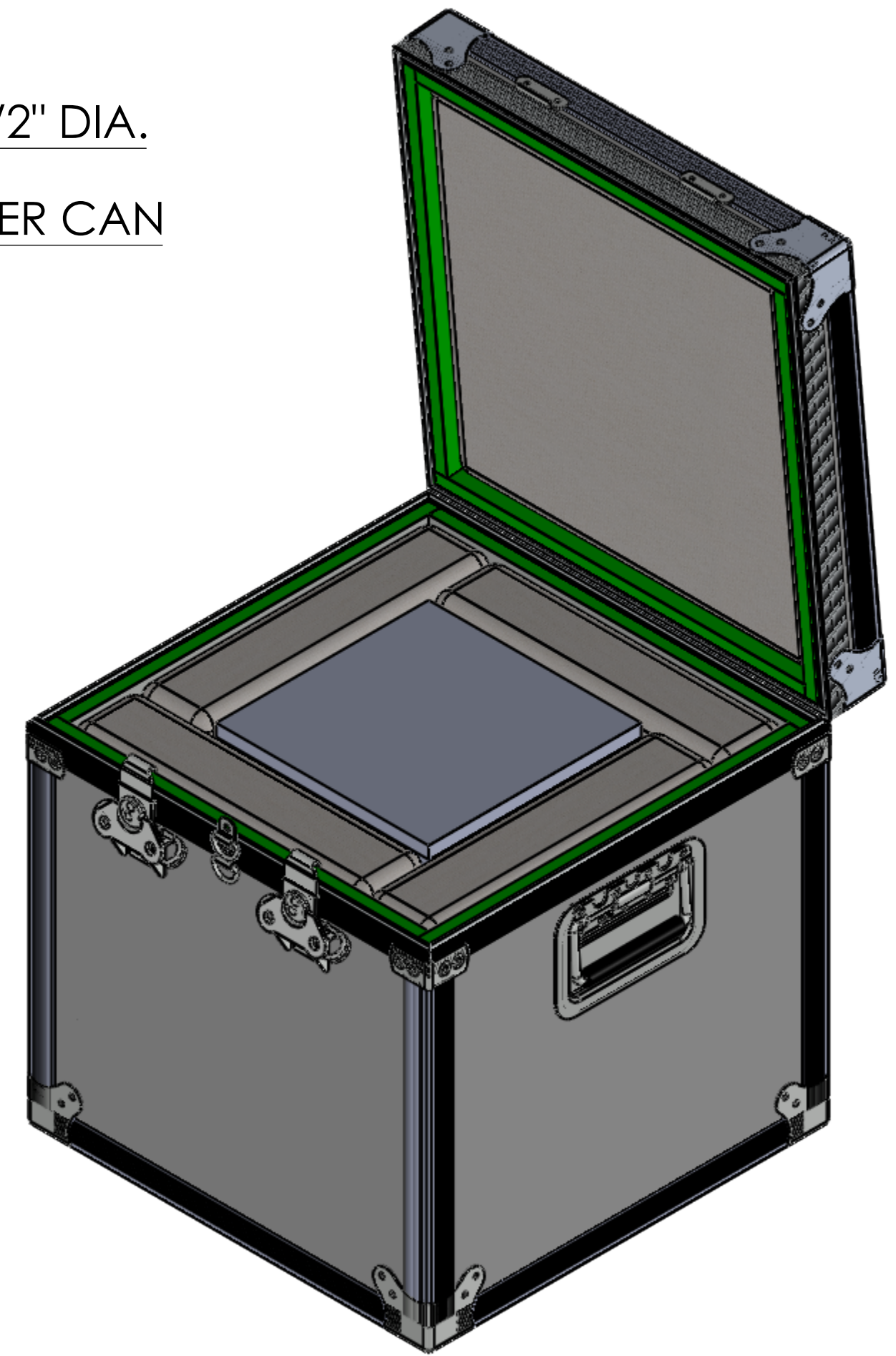
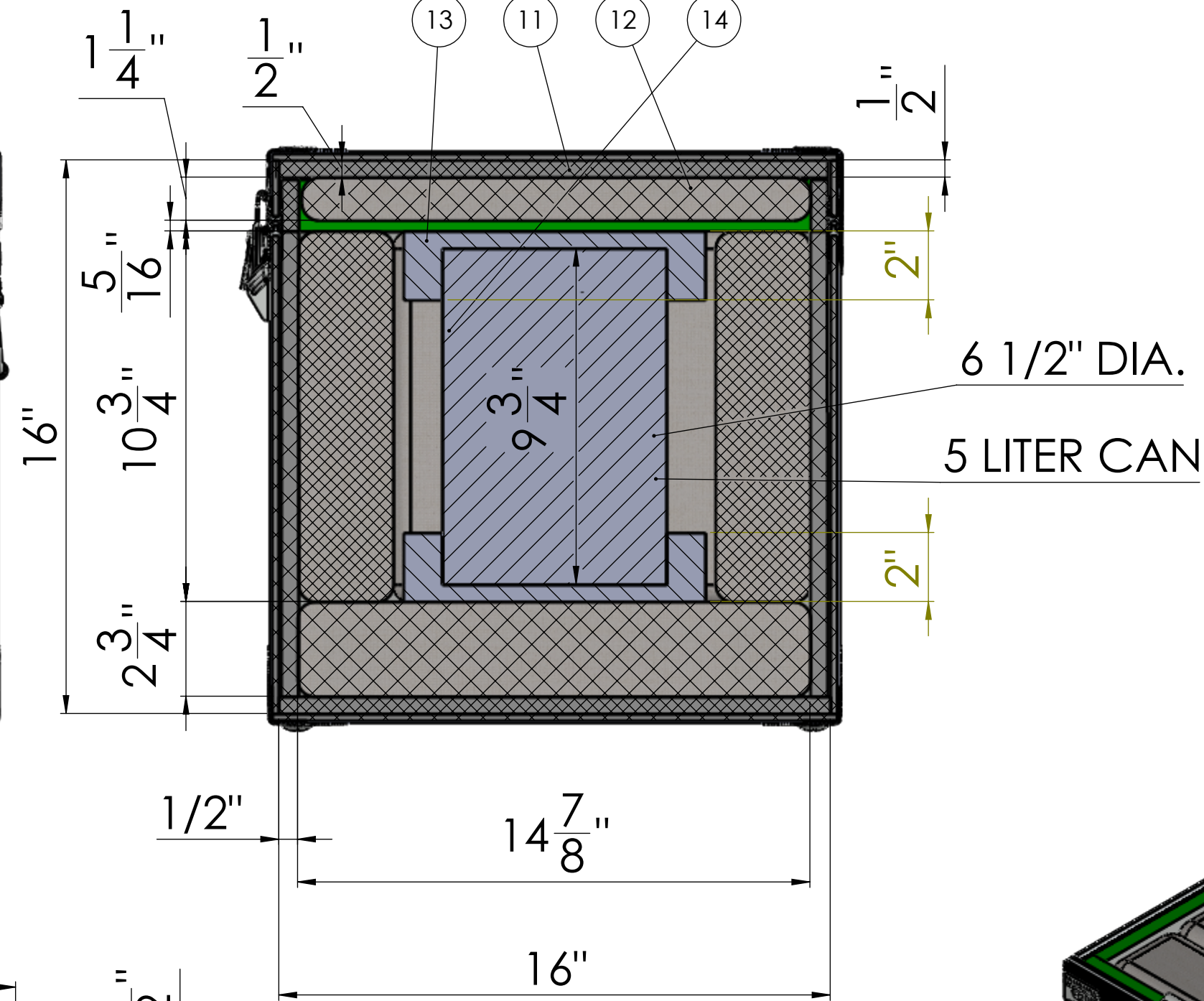
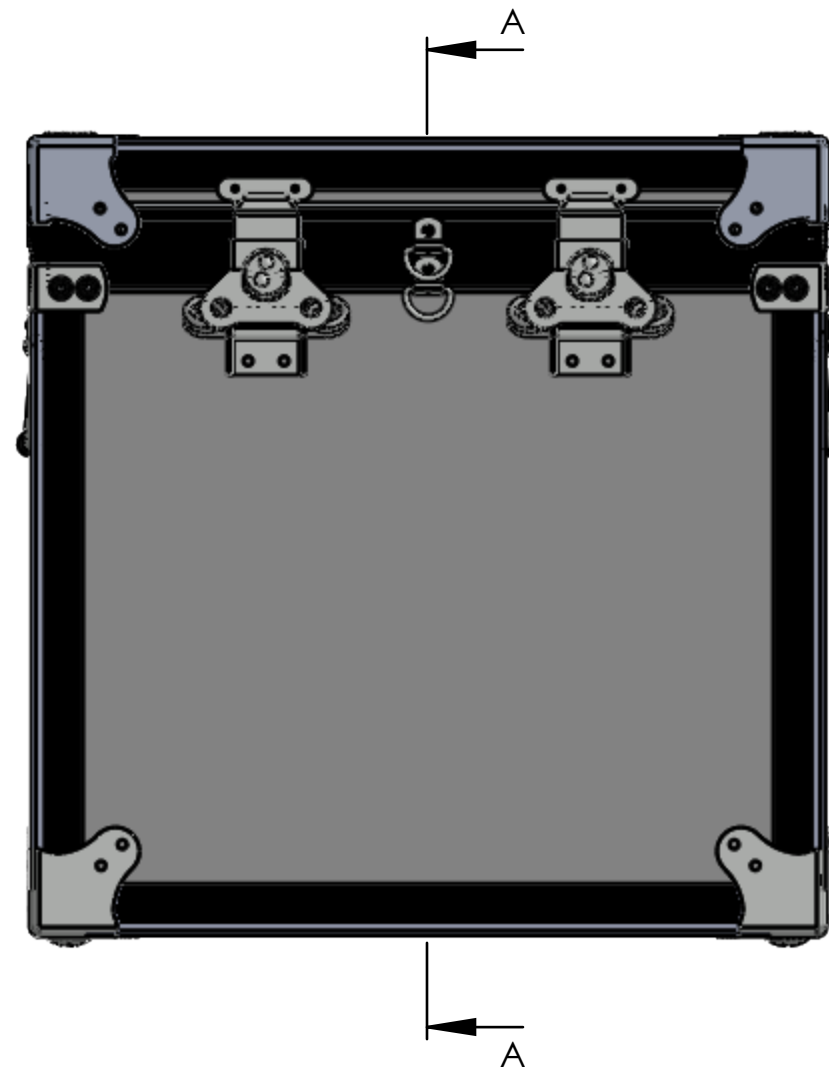

FOAM CAPS  
AND 5 LITER CAN  
SCALE 1:2

CUSTOMER APPROVED



PROPRIETARY AND CONFIDENTIAL  
THE INFORMATION CONTAINED IN THIS DRAWING IS THE SOLE PROPERTY OF VIKING PACKING. ANY REPRODUCTION IN PART OR AS A WHOLE WITHOUT THE WRITTEN PERMISSION OF VIKING PACKING IS PROHIBITED.

UNLESS OTHERWISE SPECIFIED:  
DIMENSIONS ARE IN INCHES  
TOLERANCES:  
FRACTIONAL: ± 1/8"  
ANGULAR: MACH ± BEND ±  
TWO PLACE DECIMAL ±  
THREE PLACE DECIMAL ±.125"

	NAME	DATE
DRAWN	KCS	10/20/16
CHECKED	JL	10/20/16
ENG APPR.		
MFG APPR.		

TITLE:		VPSBXKT-001C
Q.A.		
COMMENTS:		

SIZE	DWG. NO.	REV
C	001	0
SCALE: 1:4	WEIGHT:	SHEET 2 OF 2

4

3

2

1

D

C

B

A