

Delay Helicity Reporting

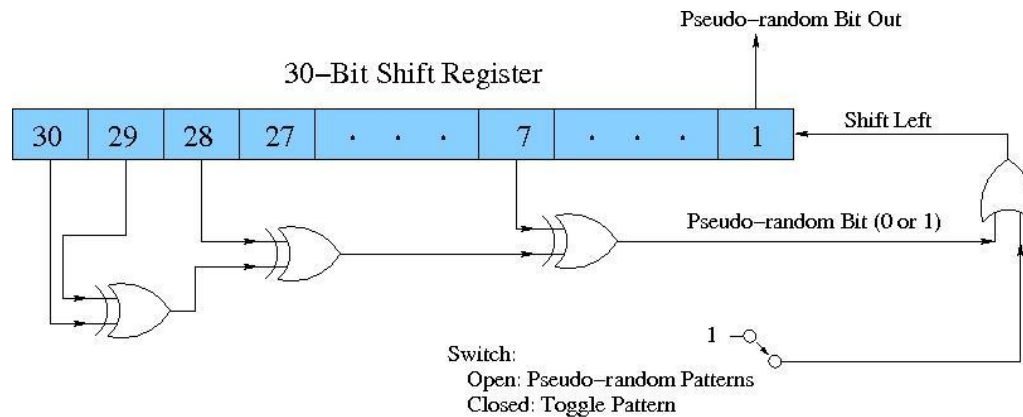

Current experiments (SIDIS, KaonLT) events tagged by delayed helicity and Tsettle status

No trigger during Tsettle – planned for A1n/d2n

Still able to decode helicity with aid of high resolution (4ns) DAQ clock.

Helicity scalers (for charge asymmetry) in DAQ, but no analysis software yet.

Beam Single Spin Asymmetry

Asymmetries fit to

$$\frac{A + B \sin \varphi}{1 + C \cos \varphi + D \cos 2\varphi}$$

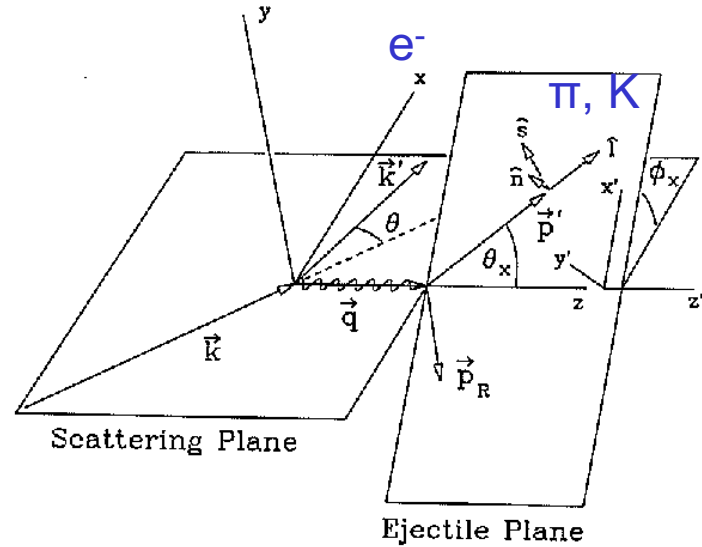

Pion Asymmetry

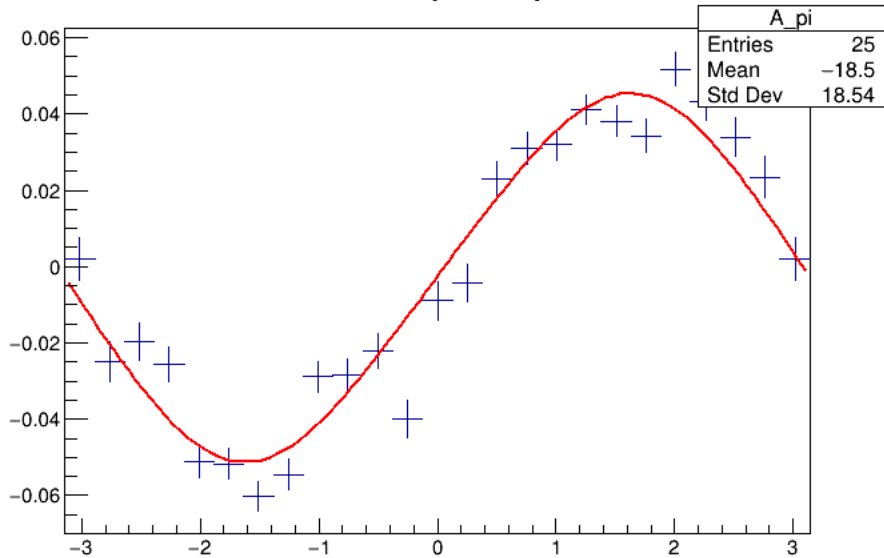

Kaon Asymmetry

