

Estimations of Collective Instabilities for JLEIC

Rui Li

JLEIC Collaboration Meeting
4-3-2016

Collective Effects in JLEIC

Electron Ring	Ion Rings	Electron Cooler
<ul style="list-style-type: none"> • Incoherent: Laslett tune shift, emittance growth • Coherent: Single-bunch Instability Coupled-bunch Instability • Scattering: IBS Touschek scattering Residual gas scattering • Heat load • Feedback 		<ul style="list-style-type: none"> • Space charge • CSR • BBU • Ion trapping
<ul style="list-style-type: none"> • Two-stream effects: Ion effects 	<ul style="list-style-type: none"> • Beam-Beam E-cloud effects 	

Wakefield/Impedance Effects on Collective Instabilities

- Harmful effects of wakefield/impedance on machine performance
 - Longitudinal and transverse tune shift
 - Heat load (local)
 - Phase space degradation: emittance growth, increase of energy spread, etc
 - Collective instabilities (global)
- Study of wakefield/impedance on collective instabilities

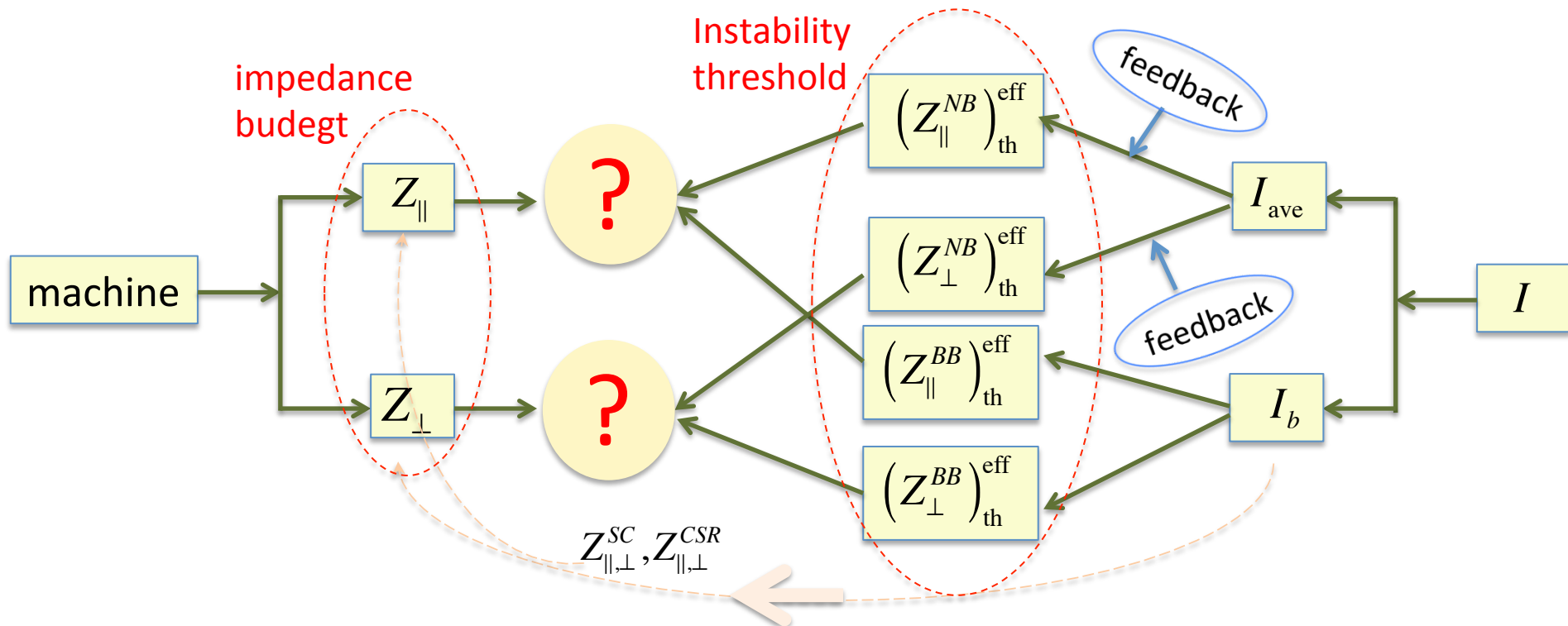

Outline

- Status of impedance estimation
- JLEIC Parameters
- Longitudinal single-bunch instability
- Transverse single-bunch instability
- Longitudinal coupled-bunch instability
- Transverse coupled-bunch instability
- Summary

Status of Impedance Estimation

Impedance Budget and Instability Assessment

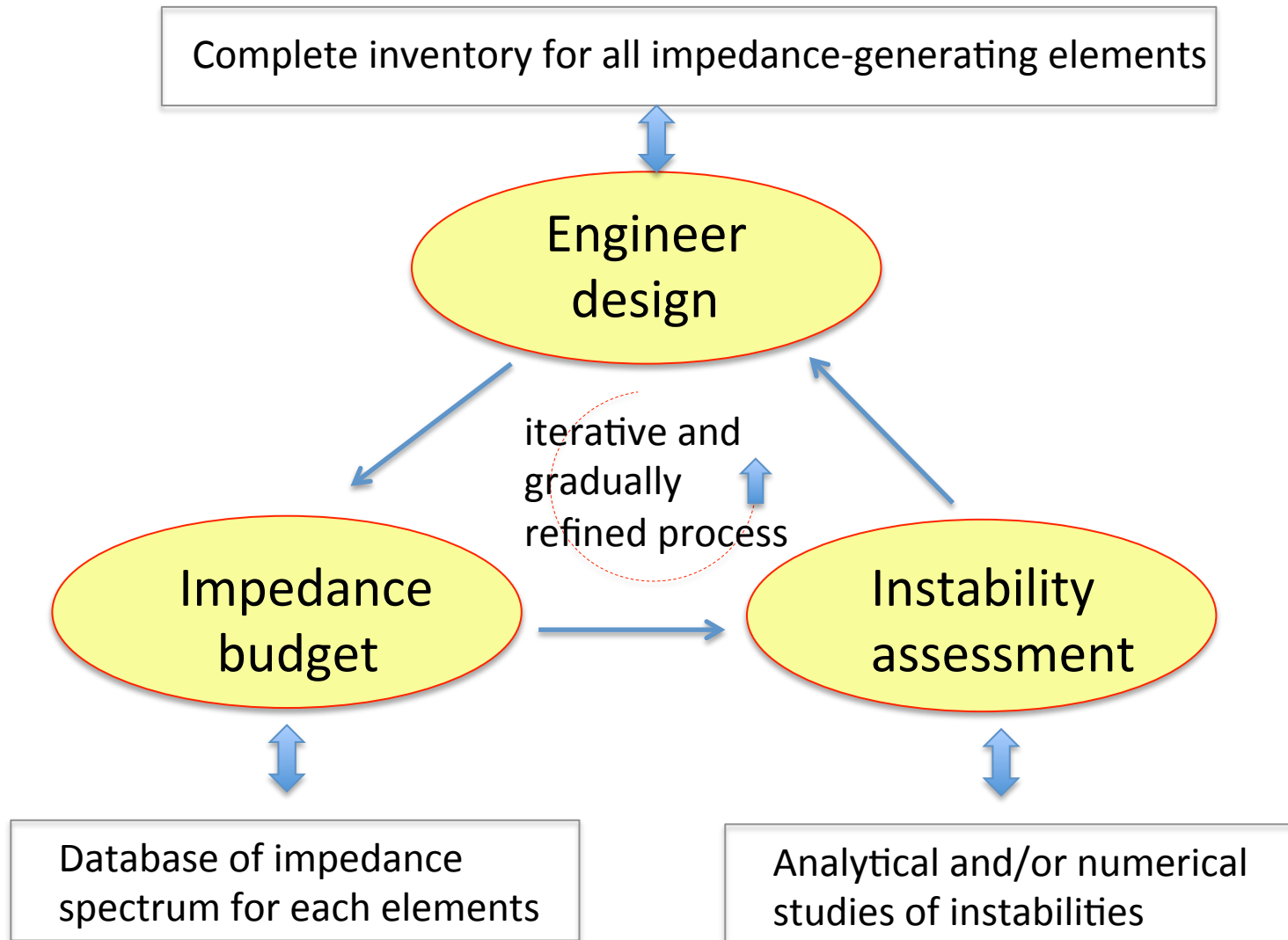

Impedance Studies for JLEIC

- We are at early stage of both engineer design and impedance budget studies
 - The estimation will be further improved as the engineer design is refined
- e-ring
 - Start with PEP-II lattice and impedance
 - Compare JLEIC from PEP-II: circumference, number of FODO cells, tapers needed, RF cavities, etc
 - Start building our inventory or database based on best possible approximations
 - Update/Iterate when new information is available
- Ion-ring
 - Start from RHIC or LHC and its impedance (but short bunches for JLEIC),
 - Compare JLEIC with RHIC: circumference, number of FODO cells, tapers needed, RF cavities, cold section, warm section, beam pipe material, (for short bunches, feedback and bpm could be very different from those used in RHIC... bunch formation...)
 - Start building our inventory or database based on best possible approximations
 - Update/Iterate when new information is available

Counts of Impedance-Generating Elements (JLEIC vs. PEP-II)

IMPEDANCE DRIVERS	PEP-II-HER		
	# / 1/12 of PEP-II	JLEIC E-Ring	JLEIC I-Ring
Flanges (Pairs)	60	1215	234
BPMs	12	405	TBD
Vacuum ports	24	480	92
Bellows	24	480	559
Vacuum Valves	1	23	14
Tapers / Transitions	1	6	6
Slots of DIP screen	3000	470k holes - holes are 3.2mm diameter	
Crab Cavities		2	8
RF/SRF Cavities		32	40
RF/SRF Bellows		0	60
RF/SRF Valves		68	24
Length of Vac Chamber		2154	2154
Vac Chamber Mat'l		Copper - arcs Stainless Steel - straights	Stainless Steel

(Courtesy to Tim Michalski)

Broadband Impedance for JLEIC e-Ring

Major $Z_{//}$ contributors	PEP-II counts	L (nH)	JLEIC counts	L (nH)	KEKB L (nH)	SuperKEKB L (nH)
BPM	290	11	405	15.4	0.8	0.6
Arc Bellows	198	13.5	480	32.7	6.6	5.1
Tapers	12	3.6	6	1.8	1.3	0.1
Flanges	582	0.47	1215	0.98	18.5	4.1
collimators	12	18.9	12	18.9	11.9	13.0
Feedback kicker	2	29.8	2	29.8	0.0	0.0
IR chamber		5.0		5.0	0.6	0.6
...
Total L (nH)		83.3		105.6	60.1	33.5

$Z_{//}/n \approx 0.07 \Omega$

$Z_{//}/n \approx 0.09 \Omega$

(S. Heifets et. al, SKAC-AP-99)

(D. Zhou, TWIICE 2 Workshop, 2016)

Goals for Impedance Studies

- Work together with RF, diagnostic, vacuum system teams to
 - obtain accurate impedance spectrum for the whole machine (as done in SuperKEKB)
 - get machine impedance within instability threshold

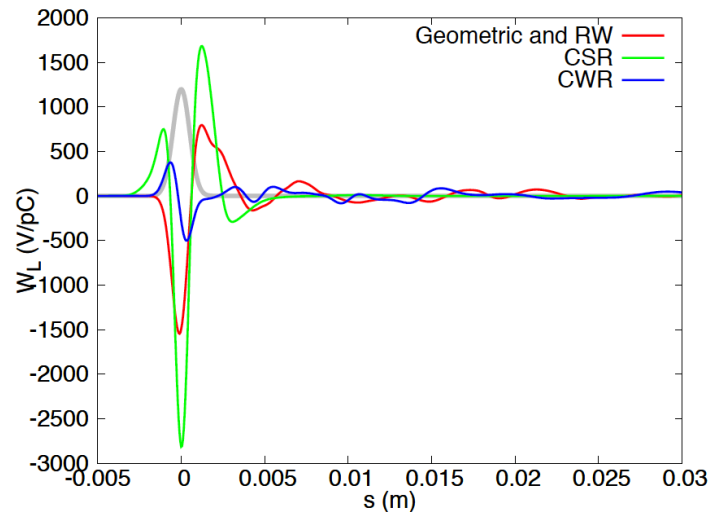
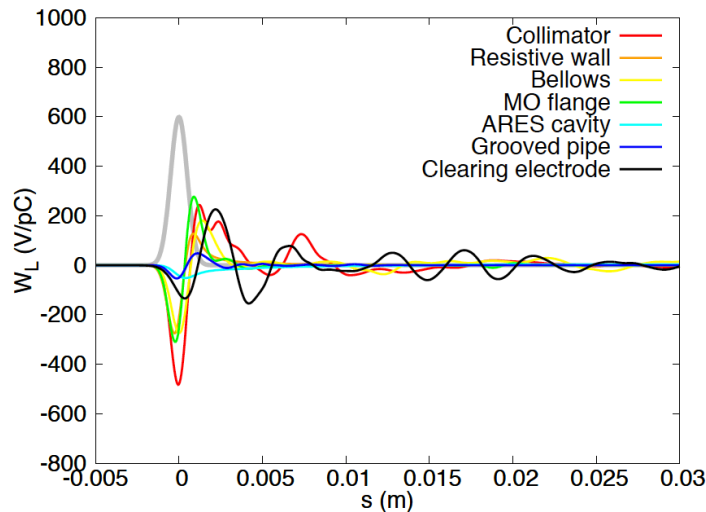

(D. Zhou, TWIICE 2 Workshop, 2016)

JLEIC Parameters for the Collider Rings

JLEIC Baseline Parameters

CM energy	GeV	21.9 (low)		44.7 (medium)		63.3 (high)	
		<i>p</i>	<i>e</i>	<i>p</i>	<i>e</i>	<i>p</i>	<i>e</i>
Beam energy	GeV	40	3	100	5	100	10
Collision frequency	MHz	476		476		476/4=119	
Particles per bunch	10 ¹⁰	0.98	3.7	0.98	3.7	3.9	3.7
Beam current	A	0.75	2.8	0.75	2.8	0.75	0.71
Polarization	%	80	80	80	80	80	75
Bunch length, RMS	cm	3	1	1	1	2.2	1
Norm. emitt., hor./vert.	μm	0.3/0.3	24/24	0.5/0.1	54/10.8	0.9/0.18	432/86.4
Horizontal & vertical β*	cm	8/8	13.5/13.5	6/1.2	5.1/1	10.5/2.1	4/0.8
Vert. beam-beam param.		0.015	0.092	0.015	0.068	0.008	0.034
Laslett tune-shift		0.06	7x10 ⁻⁴	0.055	6x10 ⁻⁴	0.056	7x10 ⁻⁵
Detector space, up/down	m	3.6/7	3.2/3	3.6/7	3.2/3	3.6/7	3.2/3
Hourglass(HG) reduction		1		0.87		0.75	
Luminosity/IP, w/HG, 10 ³³	cm ⁻² s ⁻¹	2.5		21.4		5.9	

“JLEIC Main Parameters with Strong Electron Cooling”, Y. Zhang (2017)

Parameters for the Electron Ring

Electron Ring	3 GeV	5 GeV	10 GeV
Circumference [m]		2181.39	
Pipe radius [cm]		3	
Pipe wall material		Cu	
Momentum compaction		1.09e-03	
Betatron tune (x, y)		52.7475, 52.7685	
Average beta function (x, y)		11.95, 13.15	
Number of bunches in ring	3464	3464	866
Momentum spread	2.78e-04	4.64e-04	9.28e-04
Bunch length [cm]	1.2	1.2	1.4
SR energy loss [MeVturn]	0.116	0.898	14.37
Transverse emittance [nm-rad]	2.0, 0.40	5.55, 1.11	22.2, 4.44
Transverse damping rate [1/s]	2.67	12.35	98.83
Longitudinal damping rate [1/s]	5.33	24.71	197.65
RF Voltage [MV]	0.41	2.02	17.87
# of cavities	1	2	15

(Courtesy to Fanglei Lin)

Parameters for the Proton Ring

Ion Collider Ring	40 GeV ($E_{CM}=21.9$ GeV)	10 GeV ($E_{CM}=44.7$ GeV)	100 GeV ($E_{CM}=63.3$ GeV)
Circumference[m]		2153.9	
Pipe radius [cm]		4	
Pipe wall material		Stainless Steel	
Momentum compaction		6.22e-04	
Number of bunches in ring		3254	
Momentum spread		3.0e-04	
Bunch length [cm]		1.2	
Average beta function [m]		48, 64	
Transverse emittance [nm-rad]		4.70, 0.94	
RF voltage [MV]		42.6	
# of cavities		34	
<u>Betatron tune</u> (hor., vert.)		24.22, 23.16	
Tune spread		0.003	
Chromaticity		1	

(Courtesy to Vasiliy Morozov)

Longitudinal Single Bunch Instability (e-Ring)

- Longitudinal Microwave Instability

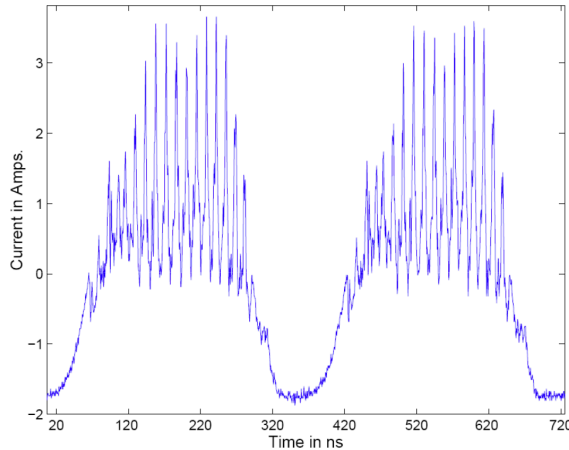

Observation at PSR
of Los Alamos

- Longitudinal Mode Coupling Instability

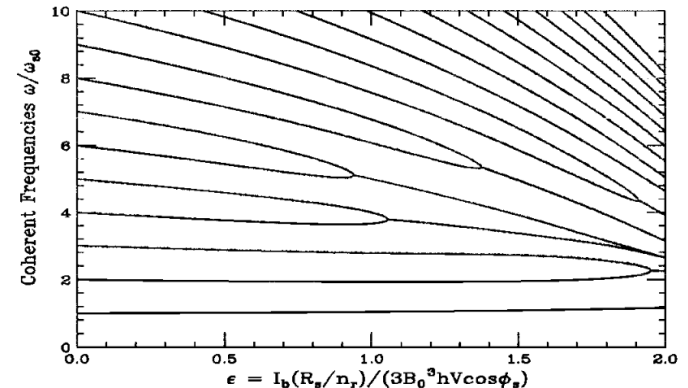
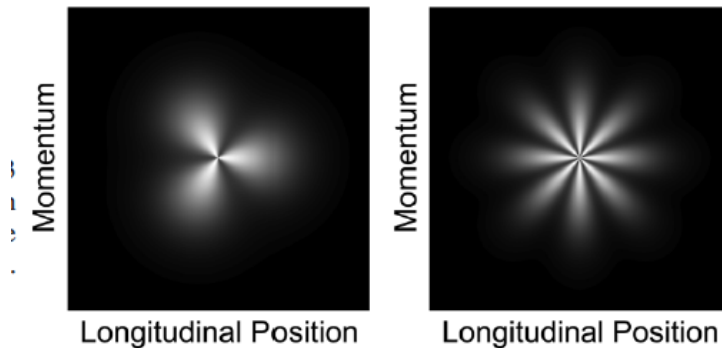

Longitudinal Single Bunch Instability (e-Ring)

- Observation at APS (2001)

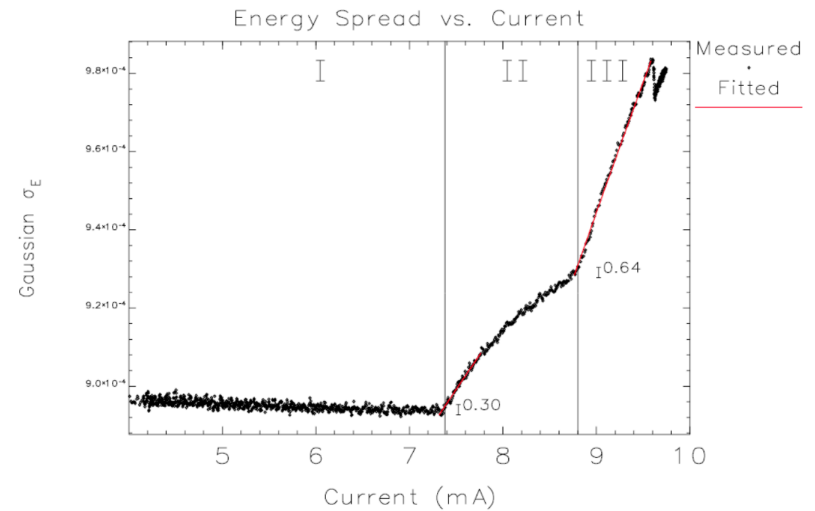
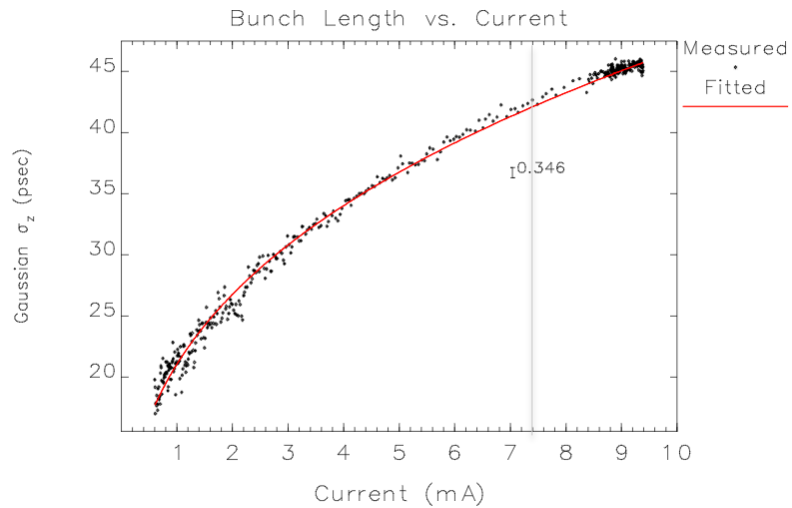

- Features: not fatal instability

Longitudinal Single Bunch Instability (e-Ring)

- Longitudinal Microwave Instability Threshold

$$\left| \frac{Z_{\parallel}(n)}{n} \right|_{\text{eff,th}} = \frac{2\pi|\eta|(E/e)\sigma_{\delta}^2}{I_{\text{peak}}}$$

	PEP-II (LER)	JLEIC Electron Ring		
E (GeV)	3.1	3	5	10
I_p (A)	113	59.0	62.35	50.6
η (10^{-3})	1.31	1.09	1.09	1.09
σ_{δ} (10^{-4})	8.0	2.78	4.55	9.28
$ Z_{\parallel}/n _{\text{eff,th}}$ [Ω]	0.145	0.027	0.125	1.16

PEP-II machine impedance
 $|Z_{\parallel}/n|_{\text{eff}} \approx 0.1 \Omega$

↓
Stable

↓
Unstable!

↓
Marginally Stable

Longitudinal Single Bunch Instability (e-Ring)

- Longitudinal Microwave Instability Threshold

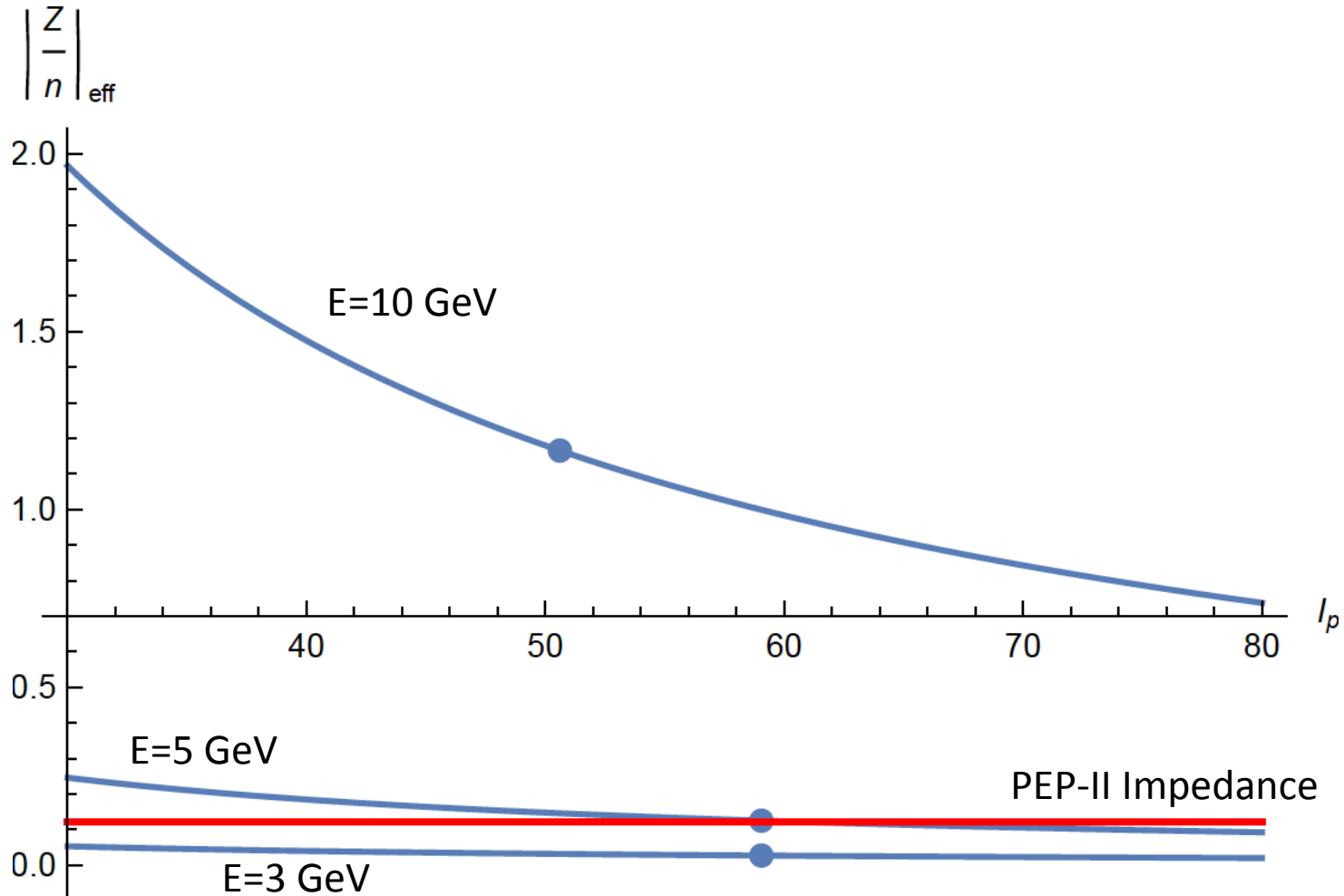

Change of e-Beam Emittance: Bending Radius

PEP-II

Low energy ring dipoles

High energy ring dipoles

High Energy Ring

Low Energy Ring

Parameter	Unit	Design	2006 (Run 5)	2006 (Run 5)	2008 (Run 7)
Energy	GeV	9 / 3.1	9 / 3.1	9 / 3.1	8-10.1 / 3.1
Beam current	A	0.75 / 2.14	1.776 / 2.95	1.9 / 3	2.069 / 3.213
# bunches				1730	1732
RF voltage	Mv	147 / 5.4	147 / 5.4	16 / 4.05	18 / 6
Bunch length	mm	15 / 15	15 / 12	12.5 / 13.5	10 / 12
Horiz.	nm-r	49 / 49	30 / 50	73 / 36	50 / 29
Vertic.	nm-r	2 / 2	0.8 / 0.8	1 / 1	0.3 / 0.3
β_y^*	mm	15 / 25	9 / 10	11 / 10	9 / 10
β_x^*	cm	50 / 50	40 / 105	74 / 21	30 / 105
ξ_y		0.03	0.058	0.058	0.05 / 0.065
Luminosity	cm ⁻² s ⁻¹	3×10^{34}	1.666×10^{34}	1.2×10^{34}	1.2×10^{34}

Matching emittance

Matching beta-star

(Y. Zhang, JLEIC R&D mtg)

Impedance issues: MWI: LER

(D. Zhou, "Accelerator Physics Challenges at SUPERKEKB", 2015)

➤ Concern of MWI in LER:

- Unknown impedance source in KEKB LER
- Lum. inversely proportional to bunch length for SuperKEKB

$$L = L_0 R_{H\theta} \quad L_0 = \frac{N_e N_p f_0 N_b}{2\pi \sqrt{\sigma_{xe}^{*2} + \sigma_{xp}^{*2}} \sqrt{\sigma_{ye}^{*2} + \sigma_{yp}^{*2}}} \quad R_{H\theta} \approx \frac{1}{\sqrt{1 + \frac{\sigma_{ze}^2 + \sigma_{zp}^2}{\sigma_{xe}^2 + \sigma_{xp}^2} \tan^2 \frac{\theta}{2}}}$$

SuperKEKB LER

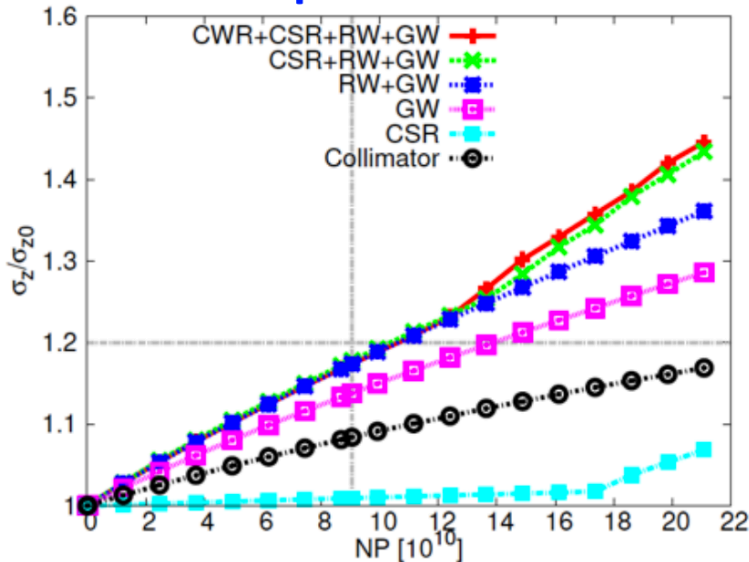

KEKB LER

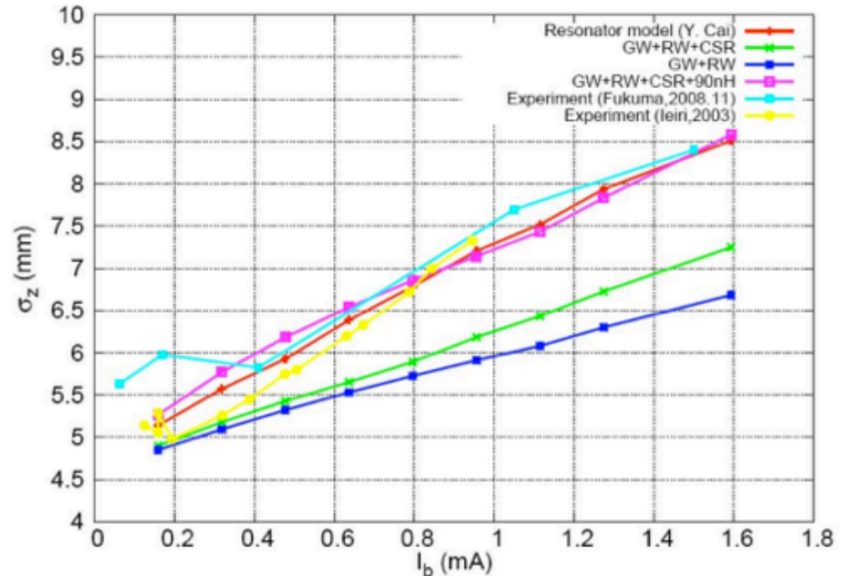

Longitudinal Single Bunch Instability (p-Ring)

- Longitudinal Single-Bunch Instability Threshold

	JLEIC	RHIC: injection	acceleration	store
E (GeV)	100	29	250	250
I_p (A)	15.6	5.4	5.4	26.6
η (10^{-3})	6.22	0.72	1.9	1.9
σ_δ (10^{-4})	3.0	4.66	0.54	2.65
$ Z_{\parallel}/n _{\text{eff,th}}$ [Ω]	22.5	5.2	1.6	7.9

Stable!

proton beam

$$N_b = 10^{11}$$

$$(\gamma_t = 22.89)$$

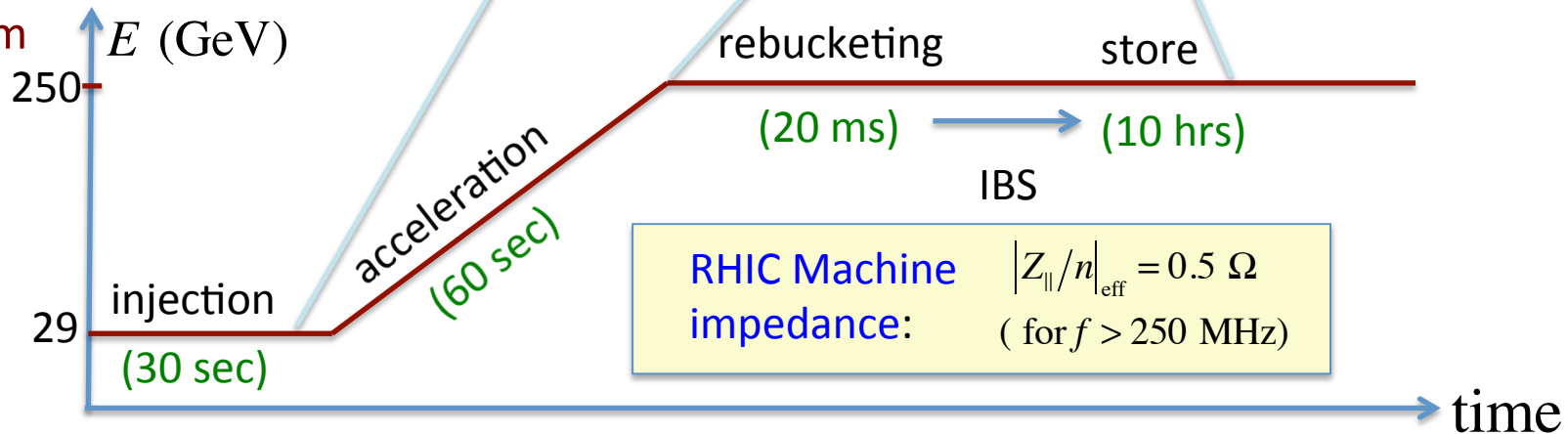

Comments

- At lower energies, the JLEIC e-beam is vulnerable to the longitudinal single bunch instability
- Comparison to the PEP-II LER case shows that the low momentum spread from JLEIC dipole configuration is not enough to provide necessary Landau damping to suppress the instability
- Accurate assessment of LSBI requires effective impedance that depends on the actual longitudinal bunch distribution, including PWD effect for e-beam and strong cooling effect for the ion beam
- Complete studies need to use full impedance information and tracking of particle dynamics

Transverse Single Bunch Instability

Transverse Single Bunch Instability

- Transverse Fast Blowup Instability

- coasting beam approximation

- Transverse Mode Coupling Instability

- Strong head-tail instability

- Head-tail instability

- Feature: fatal beam loss

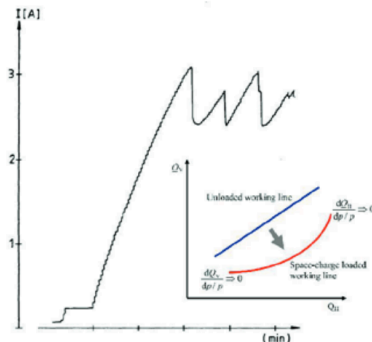

(brick-wall Instability)

Growth time faster than synchrotron period

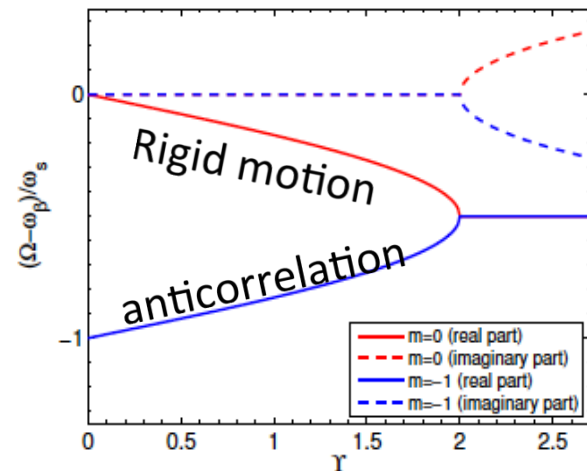

Transverse Single Bunch Instability (e-Ring)

- Transverse Mode Coupling Threshold

$$|Z_{\perp}(n)|_{\text{eff,th}} \approx \frac{16\sqrt{2}\pi}{3} \frac{(E/e)v_s}{\langle\beta_{\perp}\rangle I_{\text{peak}}}$$

(should include bunch lengthening effects)

	PEP-II (LER)	JLEIC Electron Ring		
E (GeV)	3.1	3	5	10
I_p (A)	113	59.0	62.35	50.6
v_s (10^{-2})	3.7	0.88	1.46	2.51
$\langle\beta_{\perp}\rangle$	20	13	13	13
$ Z_{\perp} _{\text{eff,th}}$ [M Ω /m]	1.2	0.81	2.25	9.0

PEP-II
 $|Z_{\perp}| = 0.5 \text{ M}\Omega / \text{m}$



Stable



Stable

In PEP-II Design Report

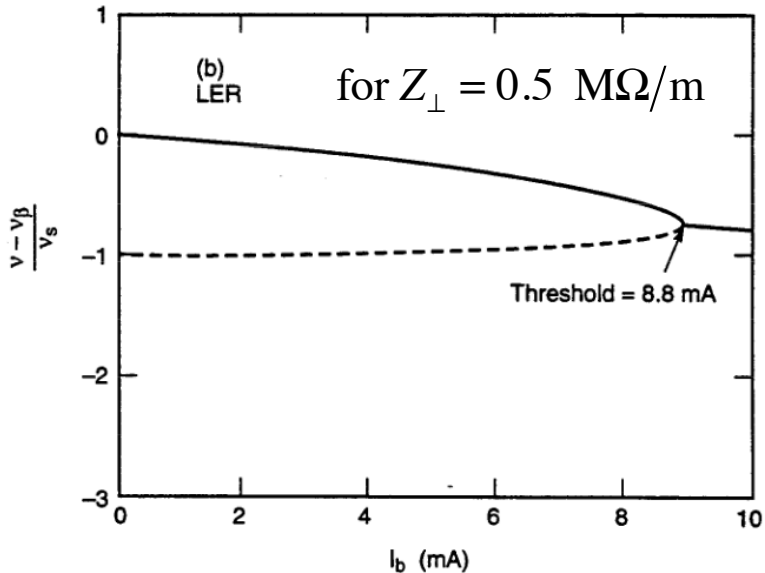
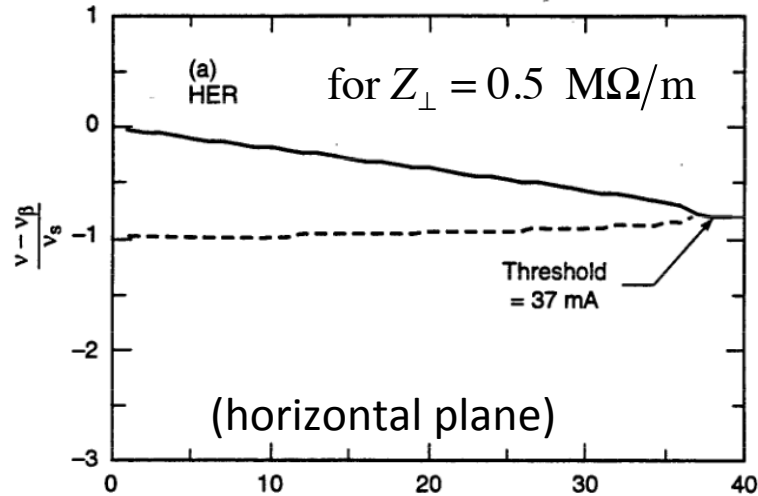

The instability sets in when $m=0$ and $m=-1$ frequencies merge.

Threshold calculated by MOSES [Chin]

$$Z_{\perp} = 1.3 \text{ M}\Omega/\text{m}$$

$$I_b = 6.5 \text{ mA (HER)}$$

$$I_b = 2.2 \text{ mA (LER)}$$

Required single bunch current:

$$I_b = 0.6 \text{ mA (HER)}$$

$$I_b = 1.3 \text{ mA (LER)}$$

\Rightarrow stable!

Transverse Single Bunch Instability (p-Ring)

- Transverse Mode Coupling Threshold

	RHIC (p-store)	JLEIC ion Ring
E (GeV)	250	100
I_p (A)	26.6	15.6
ν_s (10^{-2})	0.0043	0.053
$\langle \beta_{\perp} \rangle$	28	64
$ Z_{\perp} _{\text{eff,th}}$ [M Ω / m]	16.9	63

Stable

RHIC measured transverse BB impedance:

$$Z_{\perp}^{BB} \approx 3\text{-}5 \text{ M}\Omega/\text{m}$$

“TRANSVERSE IMPEDANCE MEASUREMENT AT THE RHIC”, S. Y. Zhang, EPAC2002

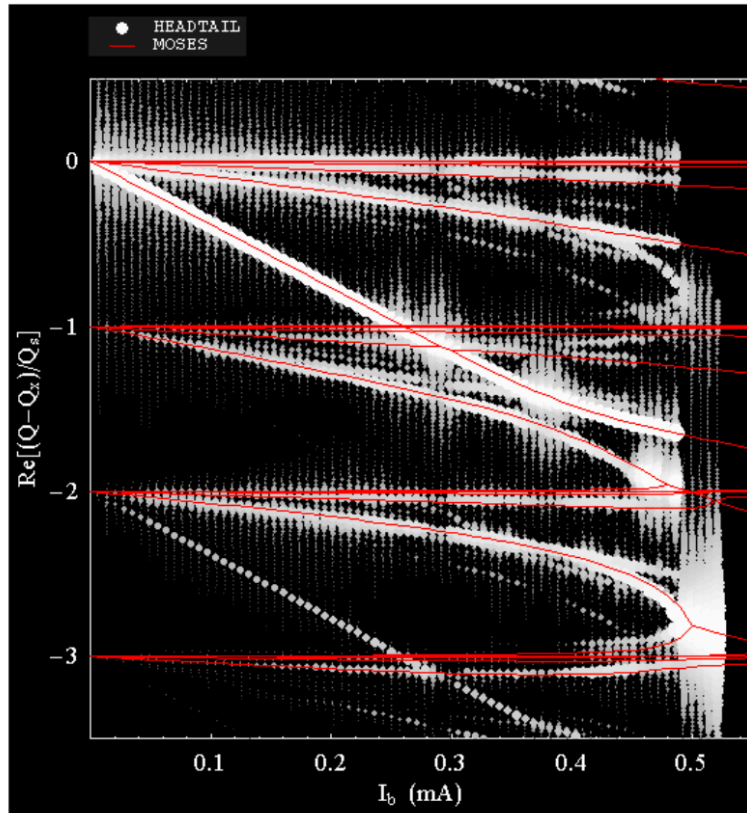

Figure 5: Comparing HEADTAIL (white dots) and MOSES (red lines). The transverse modes “0”, “-1”, “-2” and “-3” behaviour is plotted as a function of bunch intensity. The coherent motion as simulated with HEADTAIL was post-processed with SUSSIX and displayed using white dots, whose size and brightness are both non-linear functions of their spectral amplitude (bigger brighter dots have a higher amplitude than smaller darker dots).

“TRANSVERSE MODE COUPLING IN STABILITY IN THE SPS: HEADTAIL SIMULATIONS AND MOSES CALCULATIONS”

(B. Salvant, Beam’07)

- Example of betatron sideband and mode coupling from particle tracking for SPS
- Agree with MOSES results
- We need to study this after more impedance information are figured out

Coupled Bunch Instabilities in JLEIC

- Here the instability estimations are done by ZAP
(Courtesy to Ji Qiang)
- These estimations assume even filling, which tends to over-estimate the instability growth rate
- The instability grows much faster than the natural damping time, so we rely on fast feedback to control the instability
- Approach: use RF HOM impedance and designed I_{ave} to calculate LCBI or TCBI growth time, and compare with damping time of bunch-by-bunch feedback system

The State of Art for LBF System



WEOBM02 EPAC June 2008

Where we started, Where we finished

Year/run	LER stations	LER cavities	HER stations	HER cavities	I HER	I LER	L
1998	2	4	4(+1 parked)	16(+4 parked)	0.6A	1.0A	1.2E33
Run 1	2	4	5	20	0.9	1.5	3.0E33
Run 2	3	6	5	20	1.0	1.7	4.4E33
Run 3	3	6	6	22	1.1	1.9	6.3E33
Run 4	3	6	8	26	1.5	2.5	9.0E33
Run 5a	4	8	9	26	1.7	3.0	1.0E34
Run 5b	4	8	9	26	1.9	2.9	1.2E34
Run 6	4	8	11	28	1.9	3.0	1.2E34
Run 7	4	8	11	28	2.1A	3.2A	1.2E34

HER reconfigured 4 cavity -> two cavity station in Run 3, subsequently added 2 cavity stations
The operating configuration, gap voltages, tunes, etc. were constantly changing

HER current - 2x design LER Current - 1.8x design Luminosity 4X design

LOM Growth rates HER 1.2 ms⁻¹ LER 3.0 ms⁻¹ (design - simulation was damped!) $\tau_g \approx 0.3$ ms

HOM growth rates HER 3x design LER growth rates 0.45 ms⁻¹ (5.6x design) $\tau_g \approx 2.2$ ms

The PEP-II collider holds the record for stored charge in a storage ring (3.213 A at 3 GeV).

Were we successful in the feedback and LLRF areas because it was easy and we overdesigned/
overestimated things?

PEP-II Cavity Impedance for JLEIC e-Ring

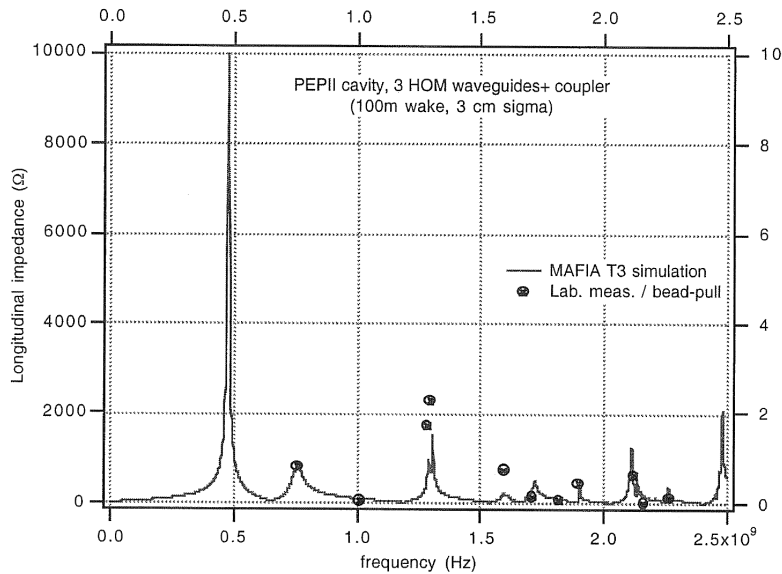

Figure 1. Calculated longitudinal impedance spectrum plus worst case estimates of modes measured in the first PEP-II cavity.

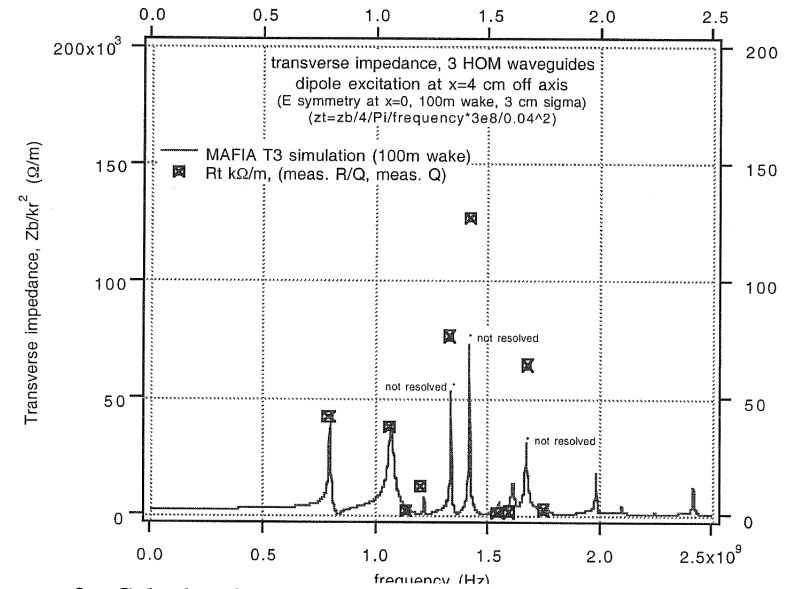

Figure 2. Calculated transverse spectrum plus estimated transverse impedance of modes measured in the first PEP-II cavity.

“PEP-II RF cavity revisited”, R. Rimmer et. al, (1999)

Impedance for PEP-II RF Cavities

Longitudinal modes

f [MHz]	<u>Rs</u> [Ohm]	Q
475	3.81e06	32469
758	810	18
1009	55	128
1283	1740	259
1295	2290	222
1595	730	300
1710	140	320
1820	70	543
1898	440	2588
2121	620	338
2160	6	119
2265	130	1975

Transverse modes

f [MHz]	<u>Rs</u> [Kohm/m]	Q
792	42.0	115
1063	38.0	27
1133	1.82	54
1202	12.2	871
1327	76.7	611
1420	126.9	1138
1542	0.89	92
1595	1.39	145
1676	64.5	783
1749	2.31	1317

“PEP-II RF cavity revisited”, R. Rimmer et. al, (1999)

(Courtesy to Shaoheng Wang)

Longitudinal Coupled-Bunch Growth Time

JLEIC Electron-ring

E [GeV]	3	5	10
$\tau_{a=1}$ [ms]	6.1	8.5	16
$\tau_{a=2}$ [ms]	118	163	199
τ_E [ms]	187.4	40.5	5.1
V_{RF} [MV]	0.40	2.02	17.87
Cavity Number	1	2	15

PEP-II LER

Table 4-32. Longitudinal coupled-bunch growth times for the PEP-II LER (3.1 GeV; $\tau_E = 19.8$ ms) at a beam current of 2.14 A.

(A) Undamped

$\tau_{a=1}$	0.03 ms
$\tau_{a=2}$	1 ms

(B) Damped to $Q = 70$

$\tau_{a=1}$	3.8 ms
$\tau_{a=2}$	180 ms

(use HOM modes only, and assume deQ factor=1)

Transverse Coupled-Bunch Growth Time

JLEIC Electron-ring

E [GeV]	3	5	10
$\tau_{a=0}$ [ms]	1.6	2.7	64
$\tau_{a=1}$ [ms]	25	39	58
τ_y [ms]	375	81	10.1
V_{RF} [MV]	0.40	2.02	17.87
Cavity Number	1	2	15

(for deQ factor=1)

(assume $\xi=1$, $\Delta v_\beta=3e-04$)

PEP-II LER

Table 4-34. Transverse coupled-bunch growth times for the PEP-II LER (3.1 GeV; $\tau_x = 40.3$ ms) at a beam current of 2.14 A.

(A) Undamped

$\tau_{a=0}$	0.1 ms
$\tau_{a=1}$	1.4 ms

(B) Damped to $Q = 70$

$\tau_{a=0}$	1.1 ms
$\tau_{a=1}$	21.4 ms

Two-Cell Cavities for the JLEIC Ion Ring

- JLEIC ion ring cavities likely require less severe damping than the JLEIC electron ring, so consider 2-cell cavities

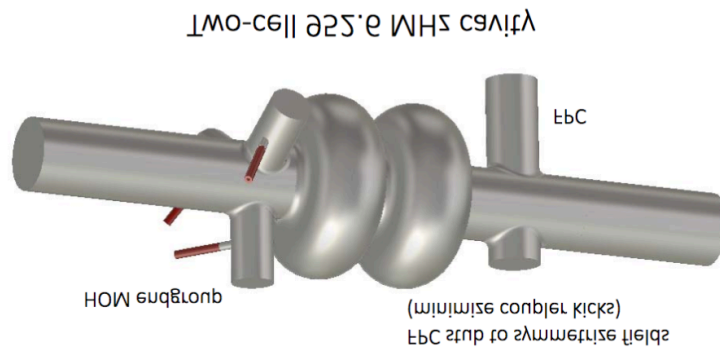

(Courtesy to Frank Marhauser)

Monopole Impedance Spectrum

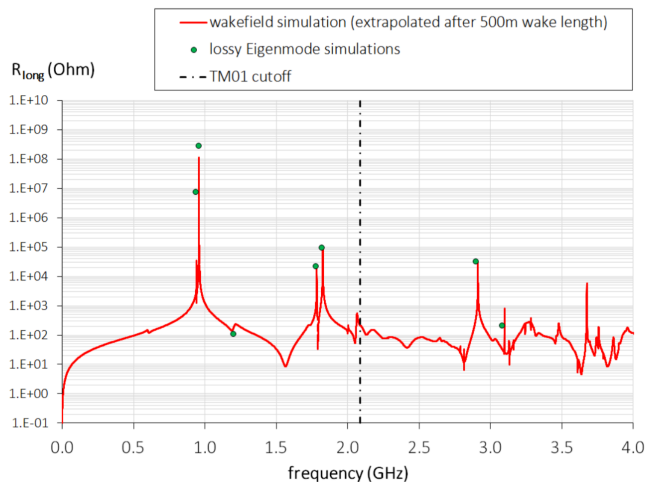

Dipole Impedance Spectrum

- The wakefield calculation (red line) has been set up to excite only the horizontally-polarized dipole modes (H)
- The Eigenmode simulations (green dots) includes the results for both horizontally and vertically polarized dipole modes

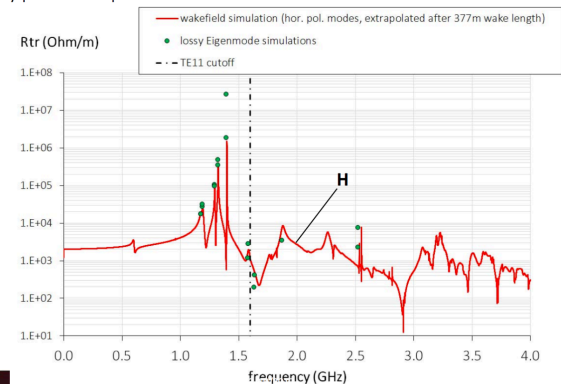

Impedance for JLEIC Ion-Ring RF Cavities

Longitudinal modes

f [MHz]	Rs [Ohm]	Q
940.8	7.98e06	2.98e06
952.6	2.95e08	2.83e06
1771.9	2.25e04	5643.9
1814.0	1.00e05	5265.5
2894.8	3.33e04	9172.4
3079.4	2.23e02	2.65e04

Transverse modes

f [MHz]	Rs [Kohm/m]	Q
792	42.0	115
1063	38.0	27
1133	1.82	54
1202	12.2	871
1327	76.7	611
1420	126.9	1138
1542	0.89	92
1595	1.39	145
1676	64.5	783
1749	2.31	1317

(Courtesy to Frank Marhauser)

Longitudinal Coupled-Bunch Growth Time

JLEIC p-ring

E [GeV]	100
$\tau_{a=1}$ [ms]	2.2
$\tau_{a=2}$ [ms]	12
V_{RF} [MV]	42.6
Cavity Number	34

(use HOM modes only,
assume deQ factor=10)

RHIC (p at injection)

HOM Frequency [MHz]	rigid mode A	ZAP τ^{-1} [sec ⁻¹]
103	1	11.3
	2	5.0
192	1	9.9
	2	0.9
276	1	2.1
	2	0.9
329	1	35
	2	13.5

→ 29 ms

Transverse Coupled-Bunch Growth Time

JLEIC
p-ring

E=100 GeV	
$\tau_{a=0}$ [ms]	8.6
$\tau_{a=1}$ [ms]	74
V_{RF} [MV]	42.6
Cavity Number	34

RHIC (p at injection)

χ	α_d [s ⁻¹]	α_{\max} [s ⁻¹]	l	s
		38 ms		
0.0	0	26.6	0	28
1.4	0	.06	5	28
2.8	0	.00	19	28
0.0	30	.002	5	2
1.4	30	.002	8	28
2.8	30	.000	—	—

(for deQ factor=1)

(assume $\xi=1$, $\Delta v_\beta=3e-04$)

Summary

- Initial estimations are done for single and coupled bunch instabilities for selected cases of JLEIC collider rings at the collision configuration
- Low energy electron beam is vulnerable for longitudinal single-bunch instability
- Both electron and proton beam requires PEP-II type of fast bunch-by-bunch feedback system to mitigate coupled bunch instability
- The estimations should be further improved as more details of the design are developed
- There are still many other types of instabilities and collective effects, and their interplay, need to be assessed