

Open Charm at JLab with the sPHENIX MAPS tracker:

PAC 54

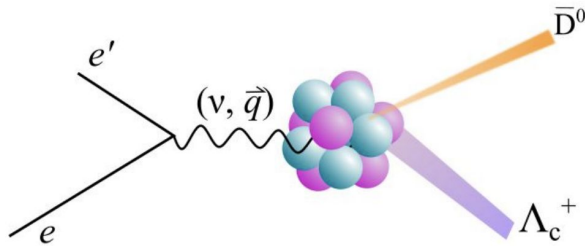

Dr. Sebouh Paul
Florida International University
on behalf of the Open Charm group
7/6/2026

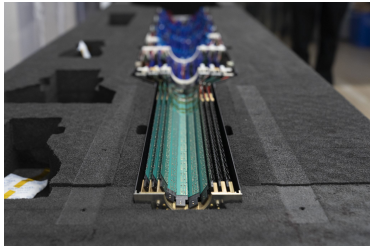

Introduction

- Open-charm production is when c and \bar{c} are produced and end up in different hadrons in the final state.
- The lightest open-charm final state available is $\bar{D}^0 \Lambda_c^+$.
- Could take place in free or bound proton
- No measurements of open-charm production (or heavy flavor in general) exist near threshold

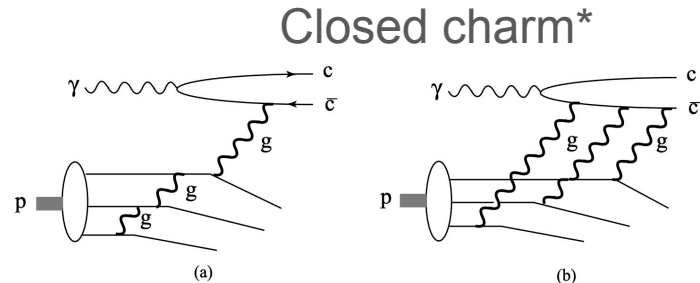
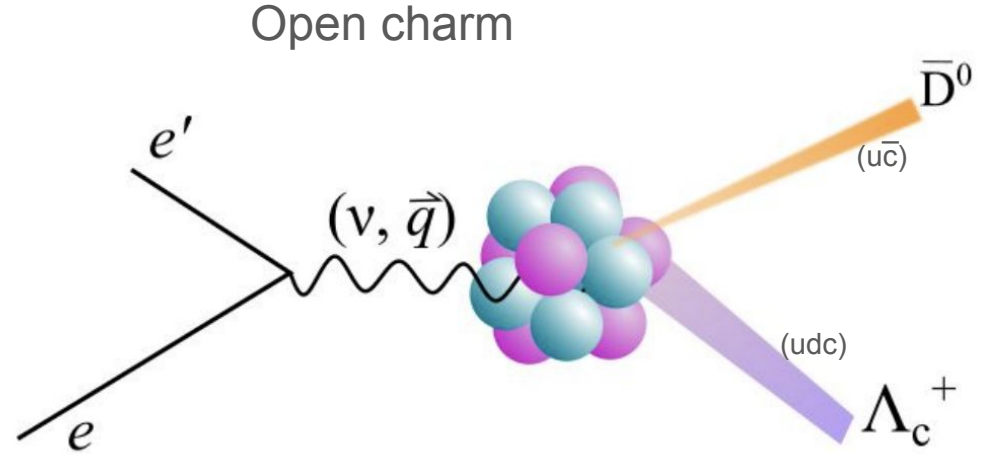

Motivation

- Measuring open-charm production in ep scattering near-threshold can reveal information about J/ψ (hidden-charm) production
- This open-charm production mechanism can also be used to probe the diquark part of the proton wavefunction

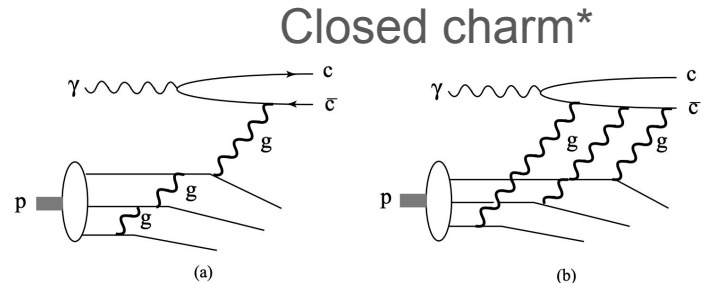
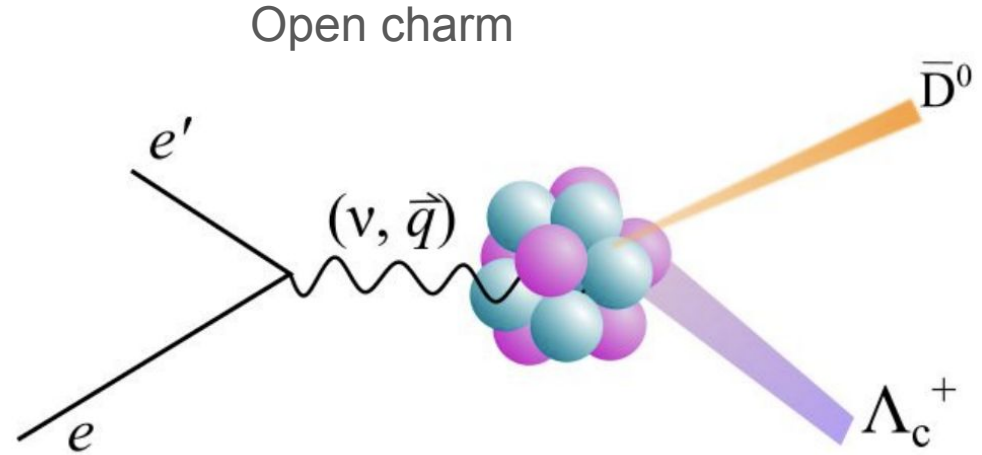

Enhanced cross-section due to di-quarks

- The presence of diquark+quark in a proton's wavefunction may affect the open-charm production if the diquark is struck, producing the Λ_c^+
- String breaking produces the $c\bar{c}$ pair.
- This would result in an enhancement of events where the \bar{D}^0 is at backwards angles in the γp center-of-mass frame

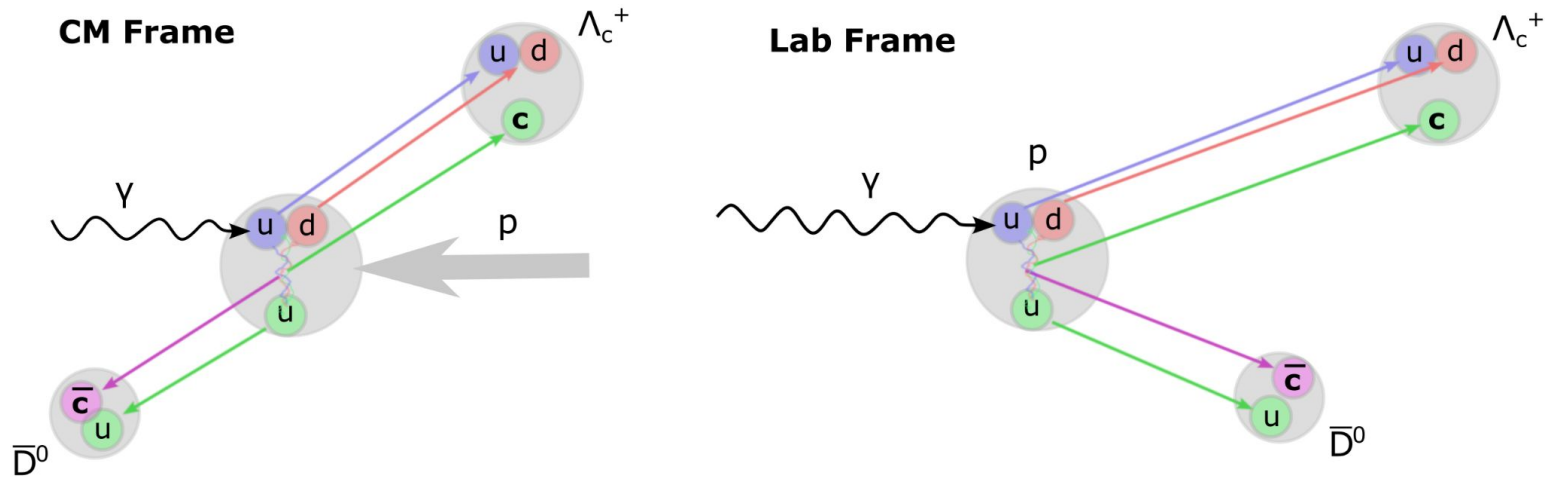

Existing open and hidden-charm measurements

- A measurement by SLAC set *upper limit only* on cross section near threshold*
- Closest *non-zero* measurements to threshold are at about 1.8 and 2.4 times the threshold**
- For comparison, J/ψ has been measured near threshold at JLab by GlueX, 007, and CLAS12.
 - Open charm cross section expected to be one to two orders of magnitude higher than J/ψ near threshold
- Difficulty in measuring open-charm comes from large hadronic background, rather than limited cross section.

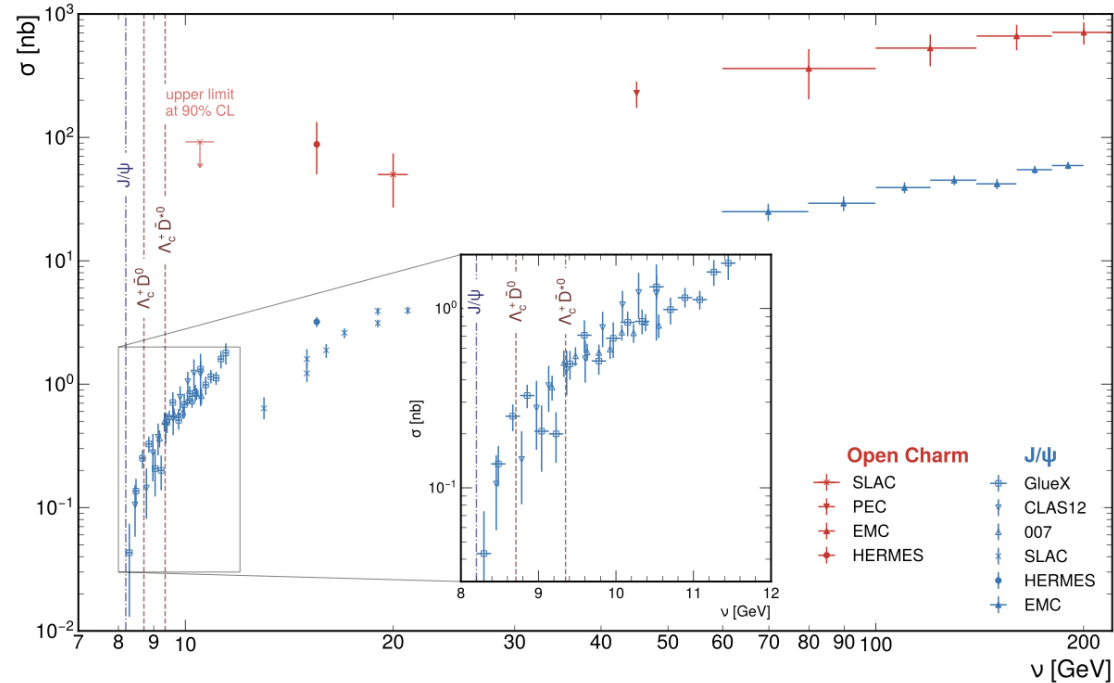

* <http://doi.org/10.1103/PhysRevD.30.694>

** doi.org/10.1103/PhysRevD.30.1 , <https://inspirehep.net/literature/553290>

What cross section do we expect?

- M.-L. Du *et al** made predictions of both open and hidden charm production near threshold
 - Recent J/ψ results show fair agreement with model.
- For open-charm, we use their lower estimate for our statistical projections
 - Agrees with independent predictions from Tomasi-Gustafsson**

*<https://doi.org/10.1140/epjc/s10052-020-08620-5>

**<https://arxiv.org/abs/hep-ph/0411295>

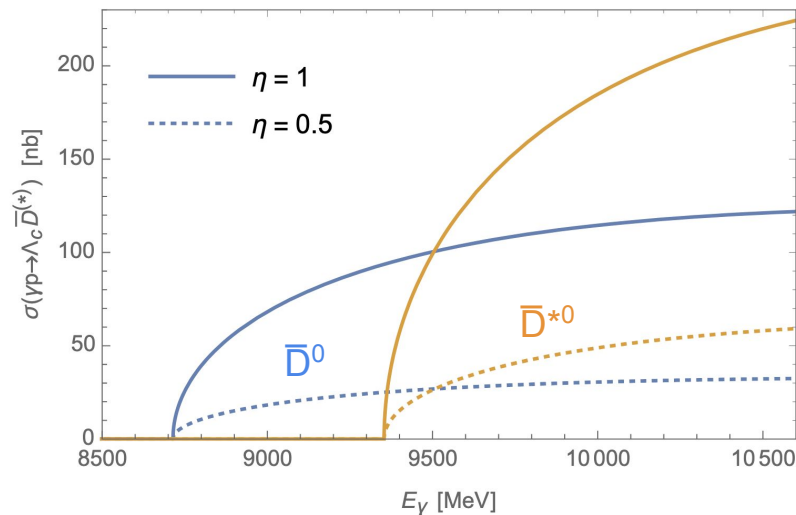
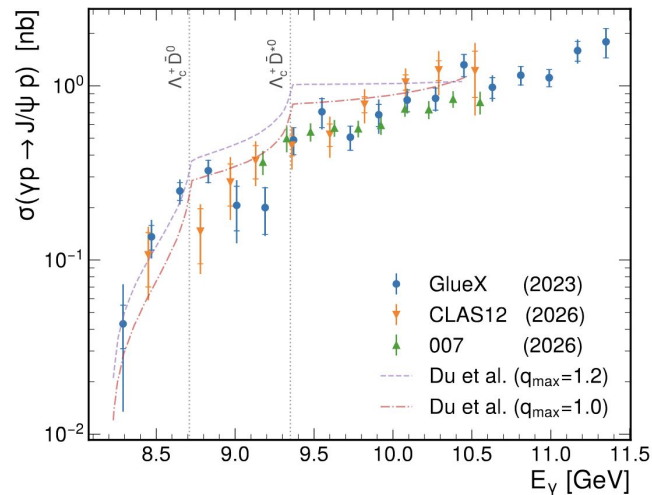

Proposed measurement with CLAS12 detector + MVTX

- Our detection strategy:
 - $\bar{D}^0 \rightarrow K^+\pi^-$ decay channel
 - Hadron pair with vertex displaced from a thin target foil, with pair mass consistent with \bar{D}^0
- 10.6 GeV e- beam, 45 nA (C+W)
- Forward tagger can measure electrons as low as 0.5 GeV:
 - Energy transfer in quasi-real photoproduction up to 10.1 GeV, while threshold for $\gamma p \rightarrow \bar{D}^0 \Lambda_c^+$ is $\nu=8.7$ GeV
- DAQ in streaming mode:
 - Data-reduction based on a triple coincidence between FT and two non-adjacent FD sectors

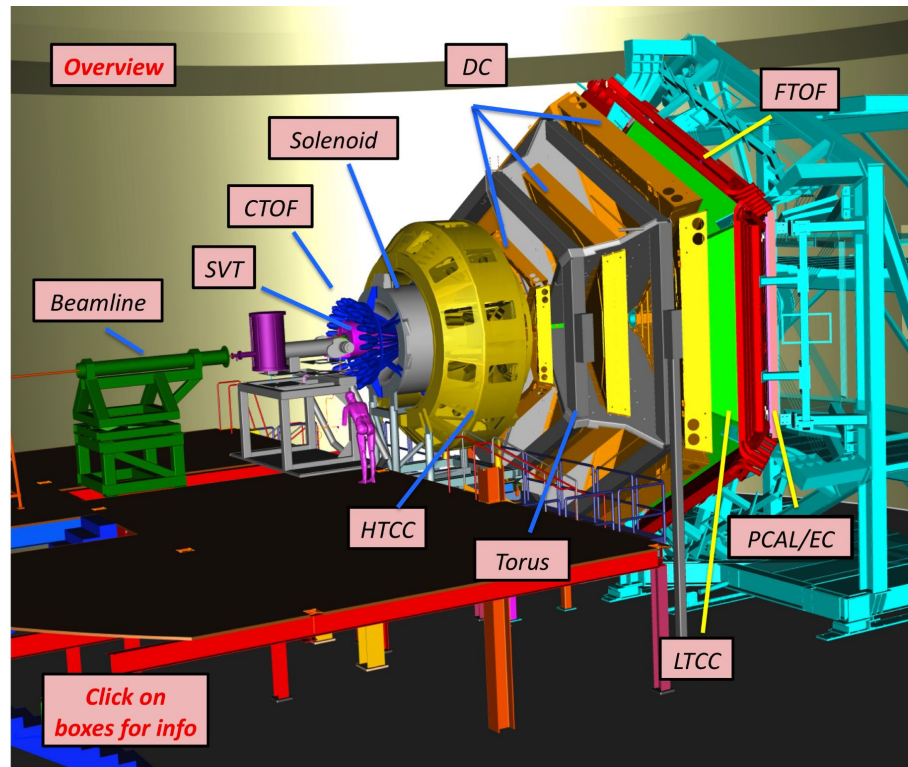

The MAPS Vertex (MVTX) Detector

- In the proposal, we plan to borrow the MVTX detector from the recently completed sPHENIX experiment
 - Pixel detector with pitch $27\ \mu\text{m}$
 - Hit position resolution $\sim 5\ \mu\text{m}$.
 - Due to crossing angle between tracks, and multiple scattering in detector support materials, the vertex resolution is estimated to be around $\sim 78\ \mu\text{m}$
 - Boosted lifetimes of charmed hadrons are $\sim 200\text{-}400\ \mu\text{m}$
 - Requiring hadron pair to have vertices $>4\sigma$ downstream of target should reduce background by at least 4 orders of magnitude

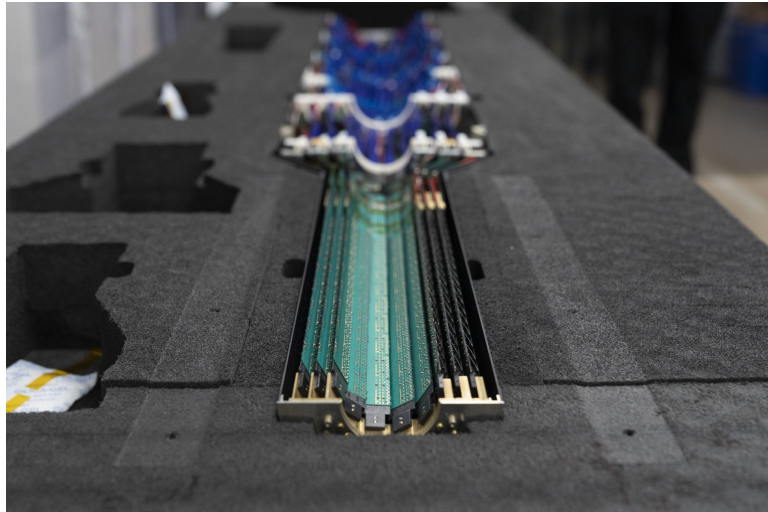
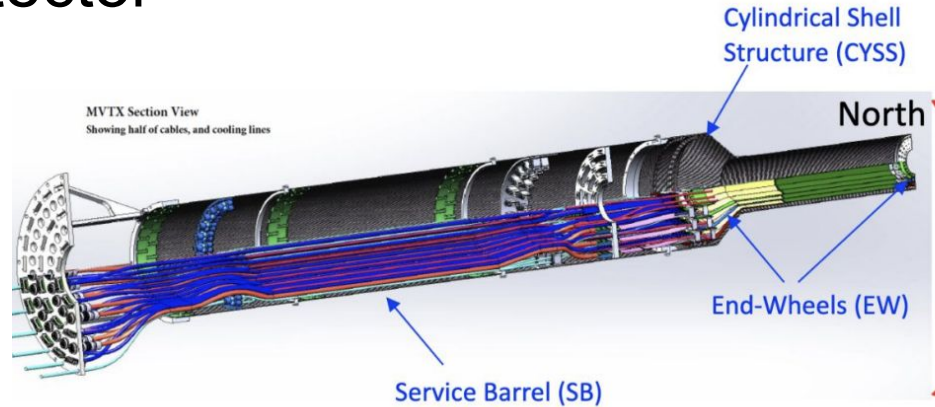

Equipment loan

- MVTX currently being transferred ownership from BNL to LANL, where it was initially developed
- Loan from LANL would include
 - The MVTX detector in its support/service barrel
 - Cables for power and readout
 - Power units
 - Front-end readout
 - Chiller system
 - Spare cables/power units and front-end readouts
- However, JLab will need to purchase FELIX boards for backend readout, and use its own servers for online data-processing
 - *BNL will be retaining its FELIX boards for EIC

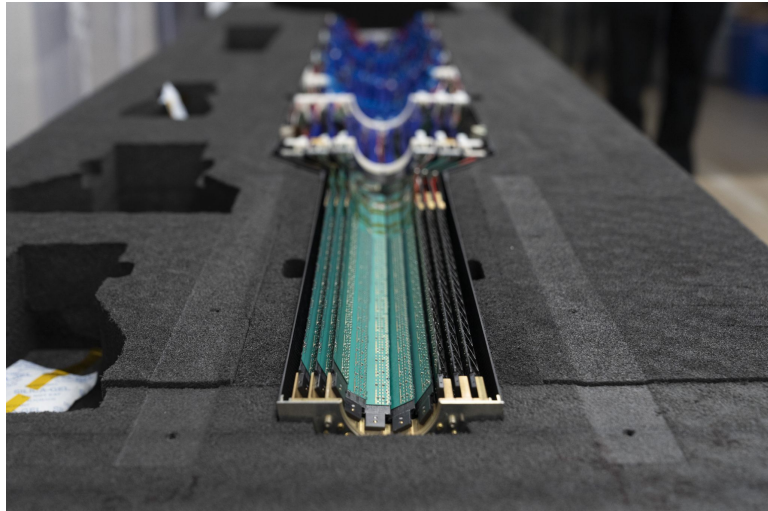
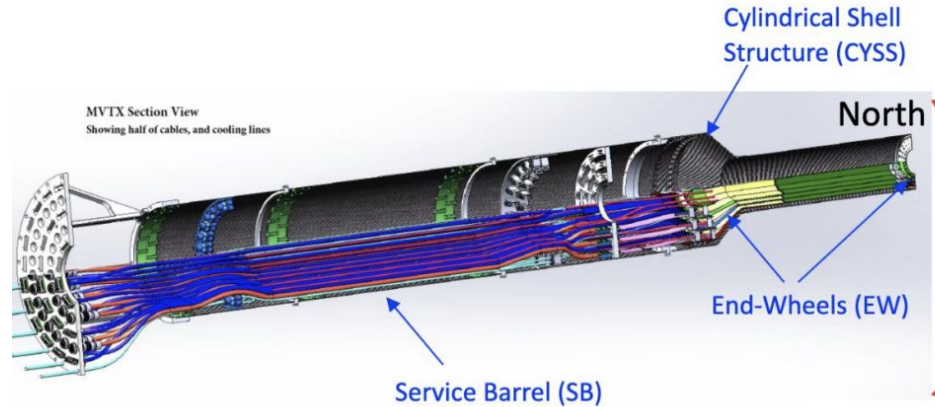

Integrating the MVTX into CLAS12

- The MVTX detector will replace the CVT during this experiment
- Target assembly would be multifoil (C+W with equal total areal density)
- Polar angle overlap between MVTX and CLAS12 drift chambers would be ~ 8.7 to 40 degrees.

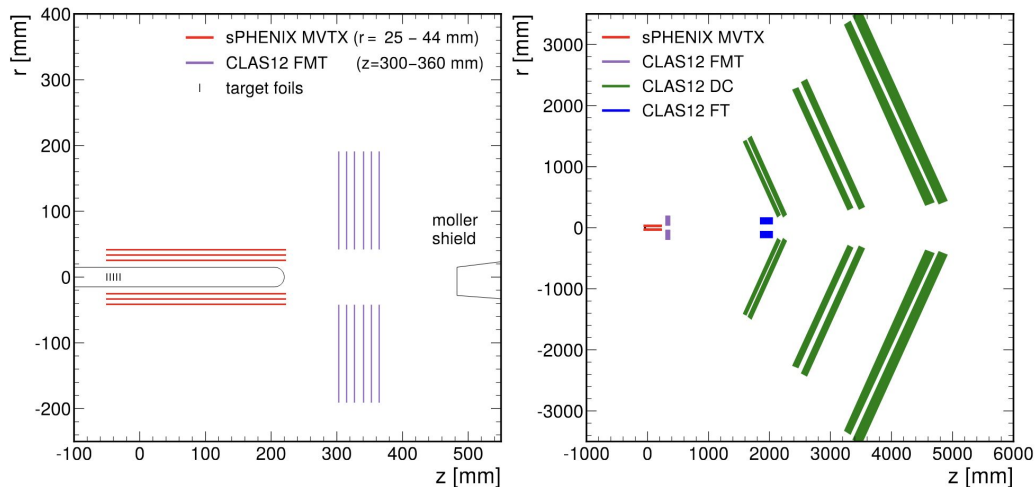
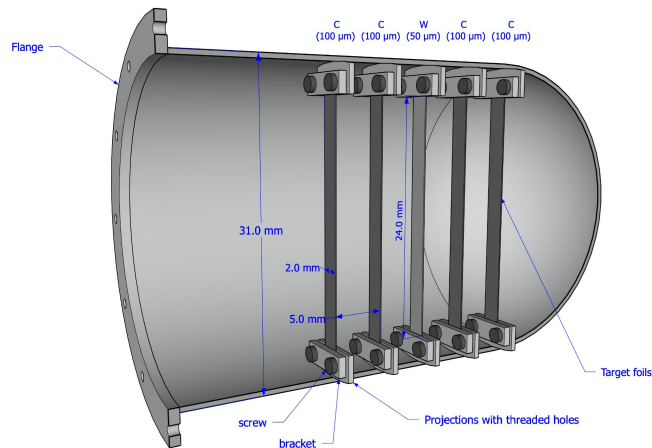
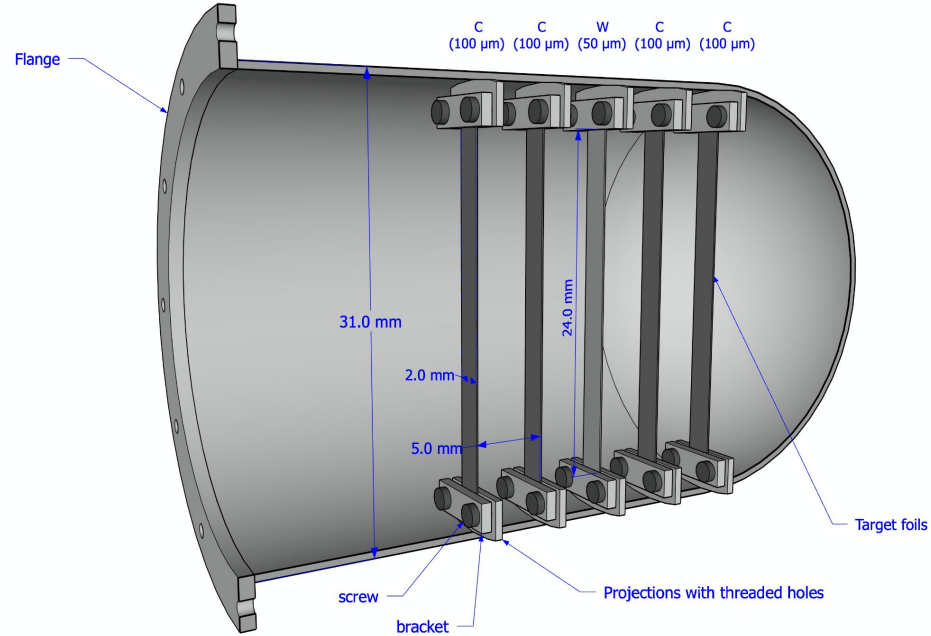

Figure 4: Placement of the MVTX inside of CLAS12. Left: zoomed-in view, right: zoomed-out view, showing the other detectors used in the proposed experiment.



Luminosity, beam current and runtime

- 200 days of runtime, corresponding to 100 PAC days.
- 45 nA
- $3.2 \times 10^{34} \text{ cm}^{-2}\text{s}^{-1}$
- $1.4 \times 10^8 \text{ nb}^{-1}$ for each target type



Preliminary target design, to be refined by the target group 12

Why two target types?

- Better grasp on the nuclear effects, such as absorption of \bar{D}^0 in the nucleus
- Allows an estimation of the cross section for the free-proton case, extrapolating from the two nuclear targets
 - Two steps: Unfold Fermi-motion smearing effects, then extrapolate for absorption effects

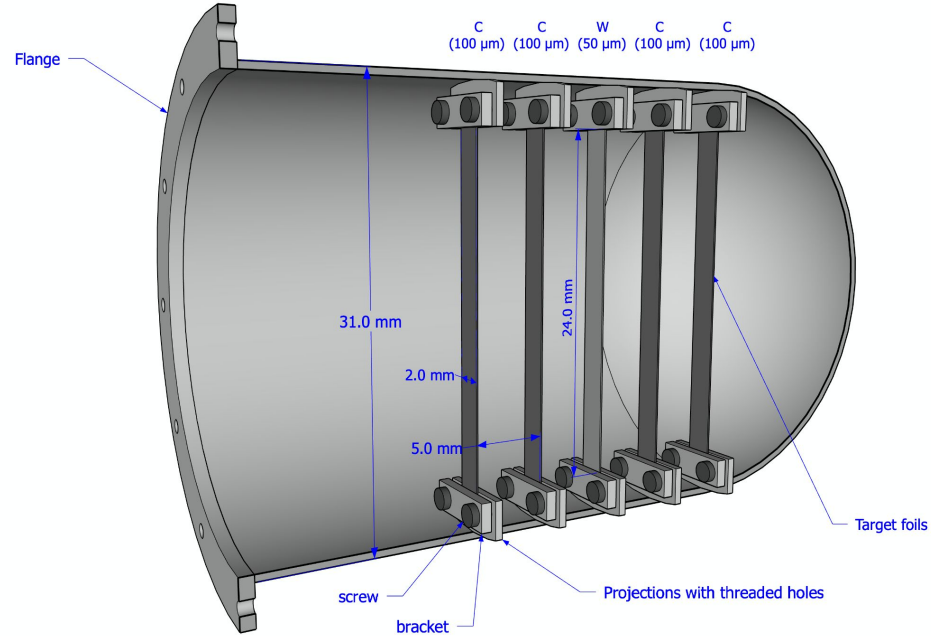

$$R_h \approx \exp(-cA^{1/3}) \implies \sigma_p = \sigma_C^{\text{corr}} \exp\left(\frac{A_H^{1/3} - A_C^{1/3}}{A_W^{1/3} - A_C^{1/3}} \times \log \frac{\sigma_W^{\text{corr}}}{\sigma_C^{\text{corr}}}\right)$$

Monte-Carlo simulations

- Phase-space simulations at generator level
- Detector simulations with GEMC, with MVTX added to the CLAS12 baseline geometry
 - Includes realistic multiple scattering of the hadrons in the target foils, MVTX, and CLAS12 baseline detector
- Resolution smearing effects for the MVTX added in post

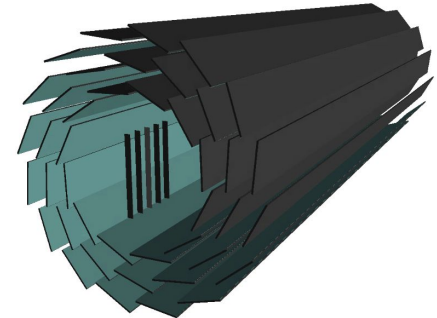
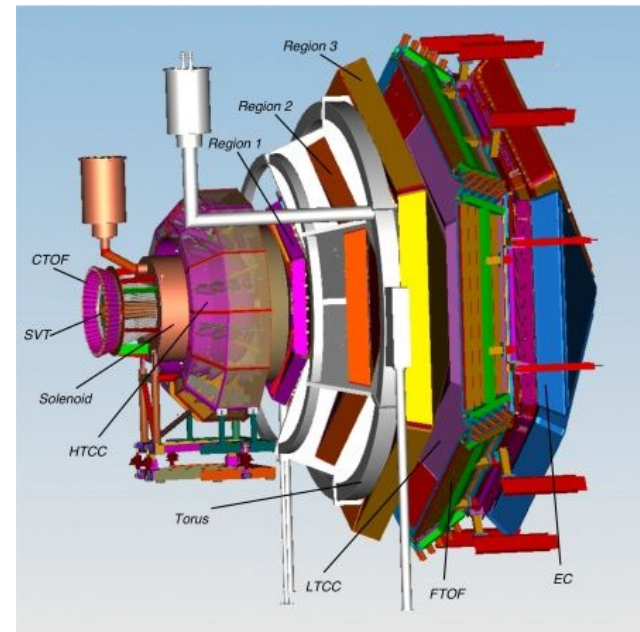

CLAS12 acceptance and mass resolution from GEMC

- Combined efficiency and acceptance for $e^- K^+ \pi^-$ is around 10.3% for MVTX+CLAS12
 - Calculated as the number of events under the mass peak divided by the number of generated events
- $\sigma = 9.2$ MeV
 - Width of mass peak

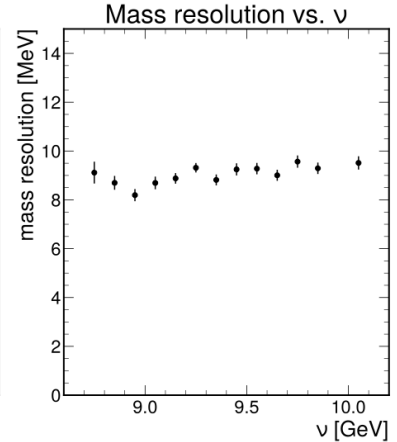
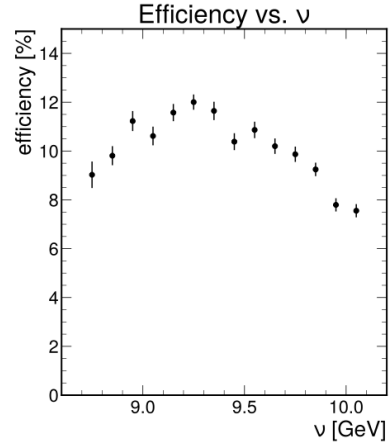
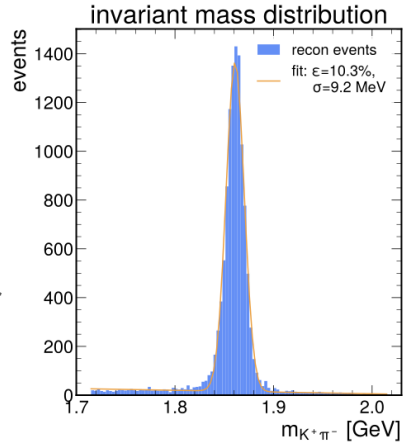

Vertex resolution

- Resolution on the z position of the vertex is $78\ \mu\text{m}$
 - Large contribution due to multiple scattering inside the support material of the MVTX
- 4σ cut at $\sim 312\ \mu\text{m}$
 - About 30% of simulated \bar{D}^0 s survive this cut
- Cuts on DOCA and x_{vtx} and y_{vtx} can also filter out part of the background

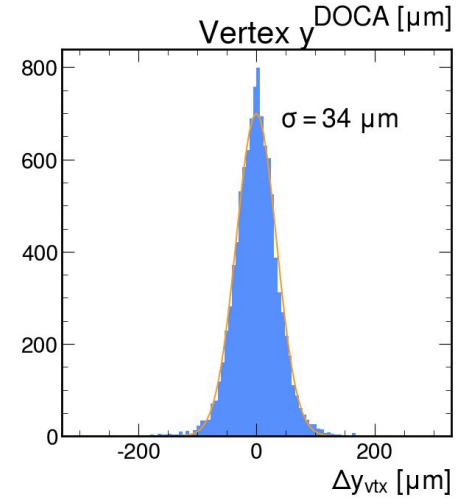
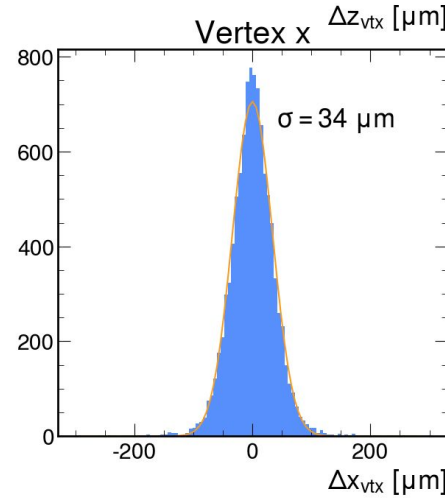
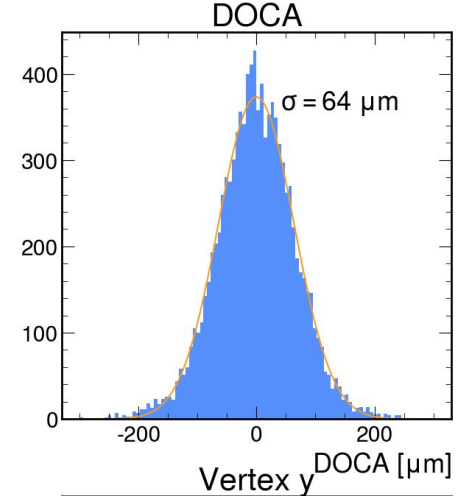
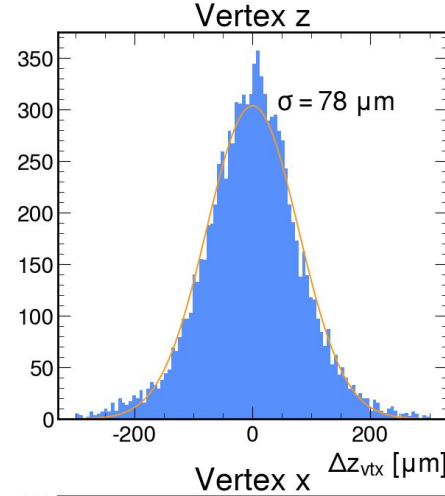

Estimation of signal rates

Quantity	C	W	notes
free-proton cross-section [nb]	0.0082		$\sigma_{\gamma p}$ calculated from Ref. [20], $\eta = 0.5$, converted to σ_{ep} Eq. (9)
Z/N	0.50	0.40	
Nuclear effects	0.85	0.55	Estimated from CLAS [57] and HERMES [56] hadron multiplicity ratios
Tot. luminosity [nb ⁻¹]	1.4×10^8	1.4×10^8	200 days, 50% PAC efficiency, 3.2×10^{34} cm ⁻² s ⁻¹ , achieved with 4-foil, 100 μ m C target and 1 foil 50 μ m W target at 45 nA; evaluated per nucleon
Branching ratio	3.945%		PDG 2025 [64]
Detector acceptance/efficiency	10.3%		GEMC simulation
v_z cut	28%	30%	assuming 100 (50) μ m C (W) foils, cut at 312 μ m
Tot. expected signal events	530	310	

Table 3: Factors and assumptions that go into the calculations for the total expected yields (bottom row).

Comparison of background before/after MVTX

Pair background estimated from existing CLAS12 data (RGA):

- Counted events with e^- in FT, h^+h^- in DC, scaled by luminosity
 - Dwarfs the expected signal by about 3 orders of magnitude

MVTX is *required* for reducing this background to a manageable amount.

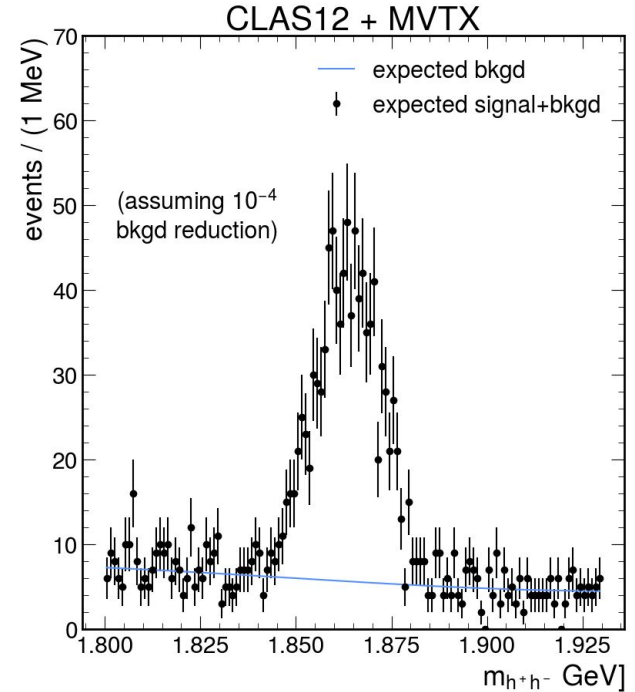
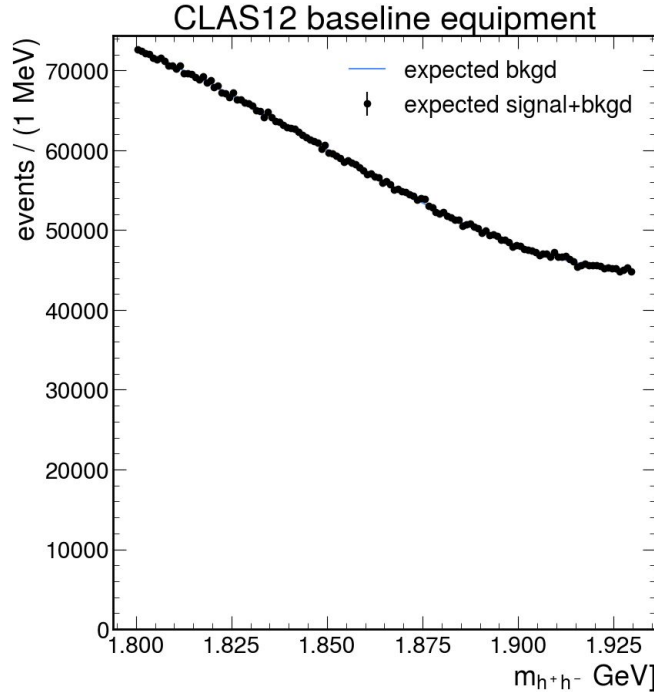

CLAS12+MVTX projections

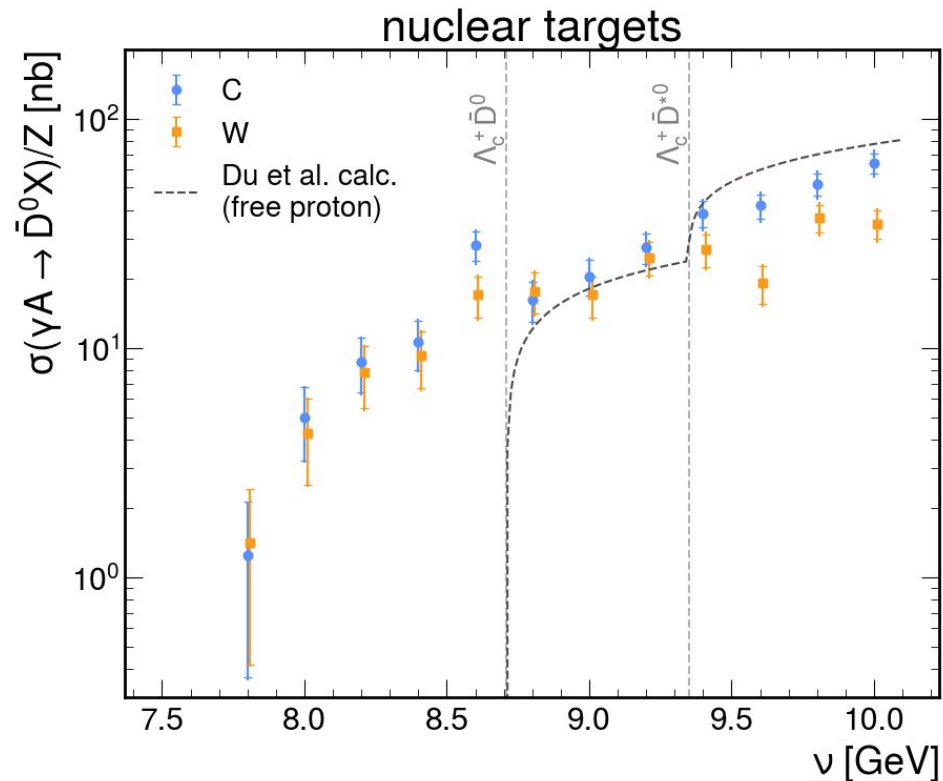

Target journal: PRL

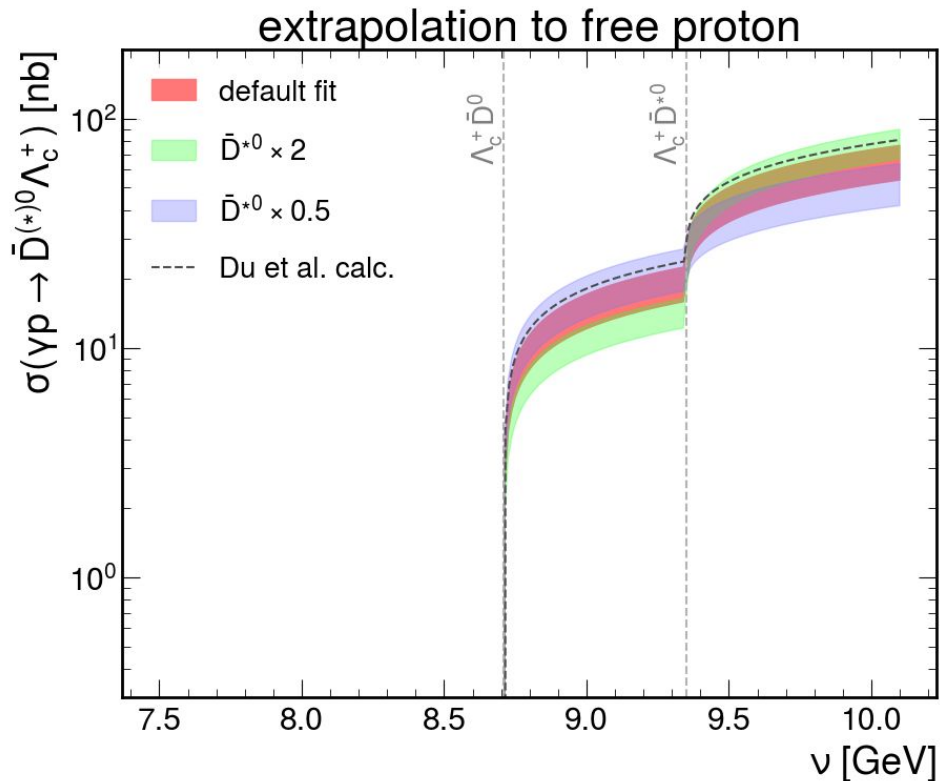

Follow-up measurement

Conclusions

- Only an upper limit has been measured for open-charm production near threshold, unlike hidden-charm (J/ψ) production
 - Open charm may reveal insights regarding J/ψ production processes, and would create a more complete charm-production program at Jefferson Lab
- CLAS12+MVTX setup is well suited for making the first-ever measurement of open-charm production (or heavy flavor in general) near threshold
- The results of the proposed measurement will be useful in a variety of other topics, including scattering-length analyses, diquark phenomena, and hadron-absorption in nuclei

Thanks for feedback and support!

Ming Liu, Bryan McKinnon, Raphaël Dupre, Pierre Chatagnon, Miriam Diamond, Holly Szumila-Vance, Christopher Guthrie, Miguel Arratia, Yuri Gotra, Hayk Hakobyan, Bob Miller, Maurizio Ungaro

Backup slides

Expected Publications

- PRL+: “First Measurement of Open-Charm Production Near Threshold”
 - Just the cross-section data for the C and W targets

Follow-up papers:

- “Excited-state production in open-charm production near threshold”
 - Determining the fraction of the events from the first paper in which the \bar{D}^0 comes from the \bar{D}^{*0} decay by finding the π^0 or γ produced in the decay of the excited state.
- “Open-charm production near threshold in γp scattering”
 - Extrapolation to the free-proton case

Additional possible measurements (Run Group)

- J/ψ on nuclear targets
 - Triggering with scattered electron in FT and/or with lepton pair in FD.
 - MVTX may improve pair mass resolution, which could reduce systematic uncertainty from fitting invariant mass distribution.
- Inclusive Λ_c^+ measurement
 - Corroboration for the inclusive \bar{D}^0 measurement, since Λ_c^+ and \bar{D}^0 would be formed together in these reactions
 - Inclusive cross sections for Λ_c^+ and \bar{D}^0 may differ from one another due to different FSI.

Systematic uncertainty

- Previous di-pion measurement* in CLAS12 had syst. uncertainties of 7.4%
- We make conservative assumptions about the amount of additional systematic uncertainty from signal extraction, and add these in quadrature
 - Mass-distribution fitting: 5%
 - Correction for vertex cut efficiency: 5%
- → Total systematic uncertainty estimate for measurements on C and W: 10%
- When extrapolating to the free-proton case, additional uncertainties come from correcting for the Fermi motion (model-dependent) and absorption effects

What percent of background events can we expect will pass the vertex cuts?

- Case 1: Both tracks are correctly matched between MVTX and DCs
 - 0.003% (probability of a gaussian distributed variable being 4σ from the mean)
- Case 2: One track is mismatched between the MVTX and DCs
 - 0.005% (estimated using GEMC)
- Case 3: One track contains a hit that does not belong to it, and the hit that should be in the track is missing
 - 0.0004% (estimated using GEMC)

Bottom line: we estimate that less than 0.01% of non-open-charm events will pass the event-selection cuts.

