

Hadron Spectroscopy at GlueX and Beyond (3)

Justin Stevens



WILLIAM & MARY

CHARTERED 1693

Confined states of quarks and gluons

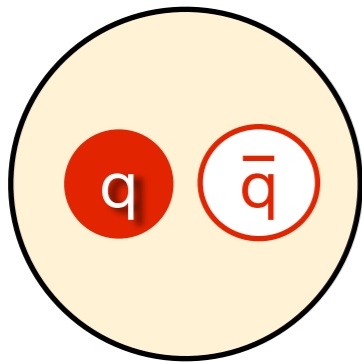

mesons

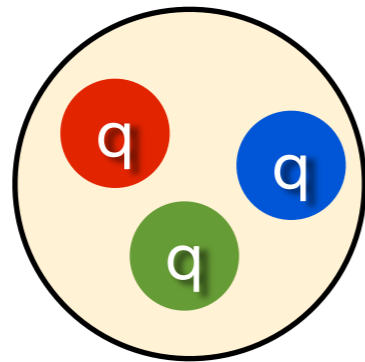

baryons

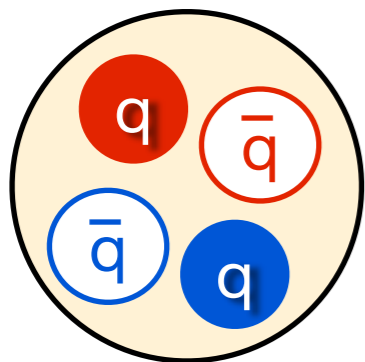

tetraquark

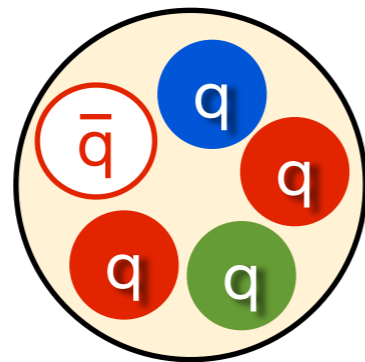

pentaquark

Observed mesons and baryons well described by 1st principles QCD

But these aren't the only states permitted by QCD

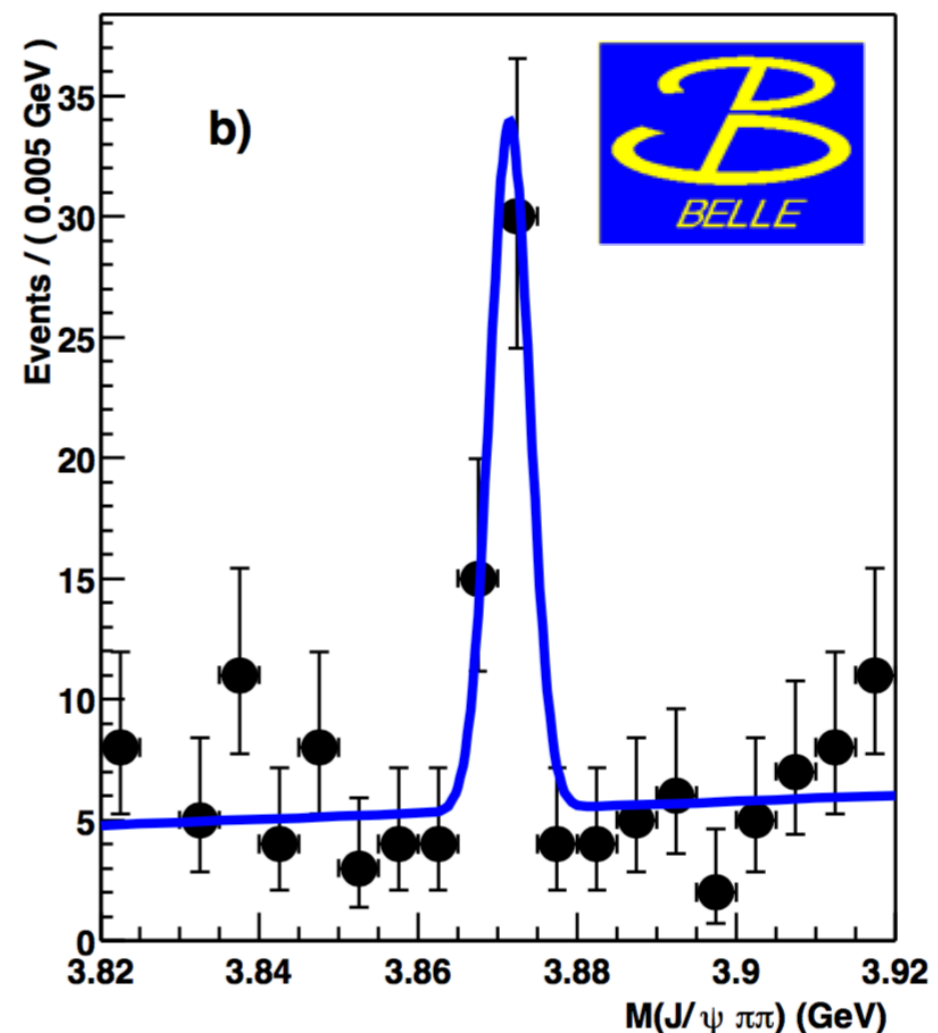

Confined states of quarks and gluons

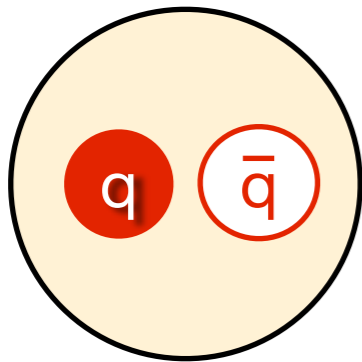

mesons

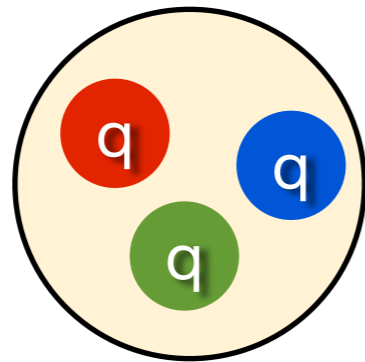

baryons

Observed mesons and baryons well described by 1st principles QCD

But these aren't the only states permitted by QCD

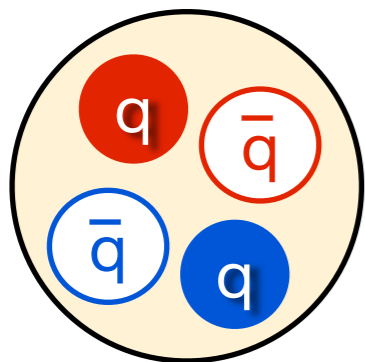

tetraquark

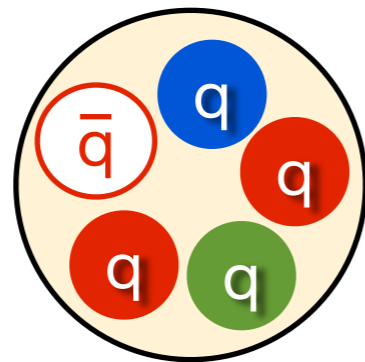

pentaquark

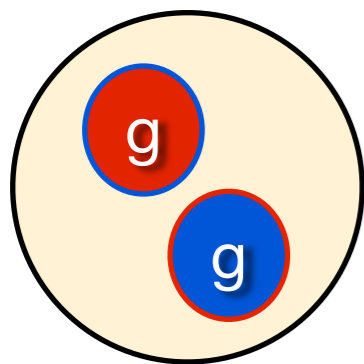

glueball

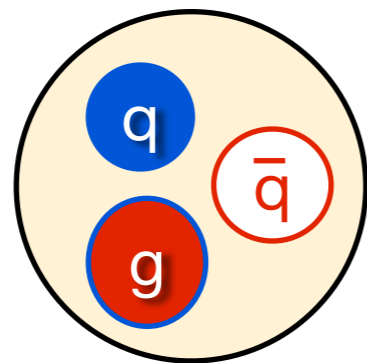

hybrid meson

Do gluonic degrees of freedom manifest themselves in the bound states we observe in nature?

Mesons in the quark model

$$J^{PC} = 1^{--}$$

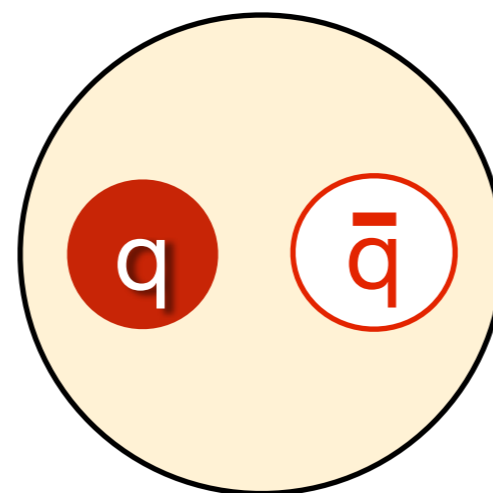
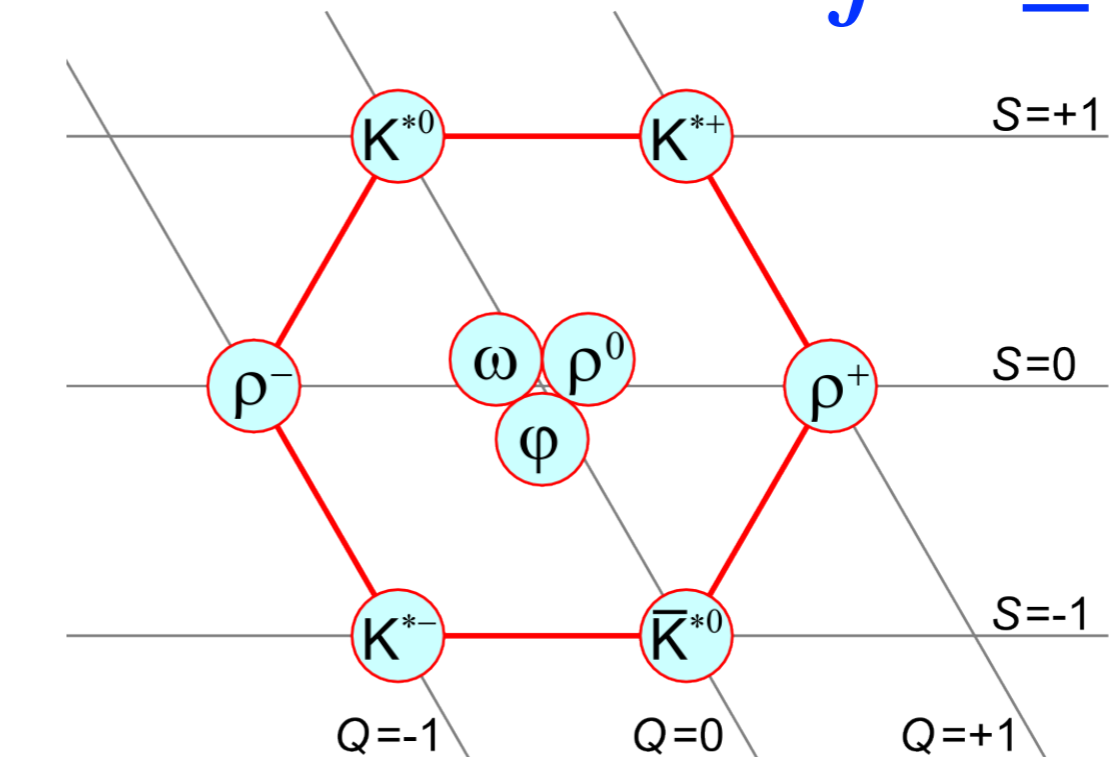
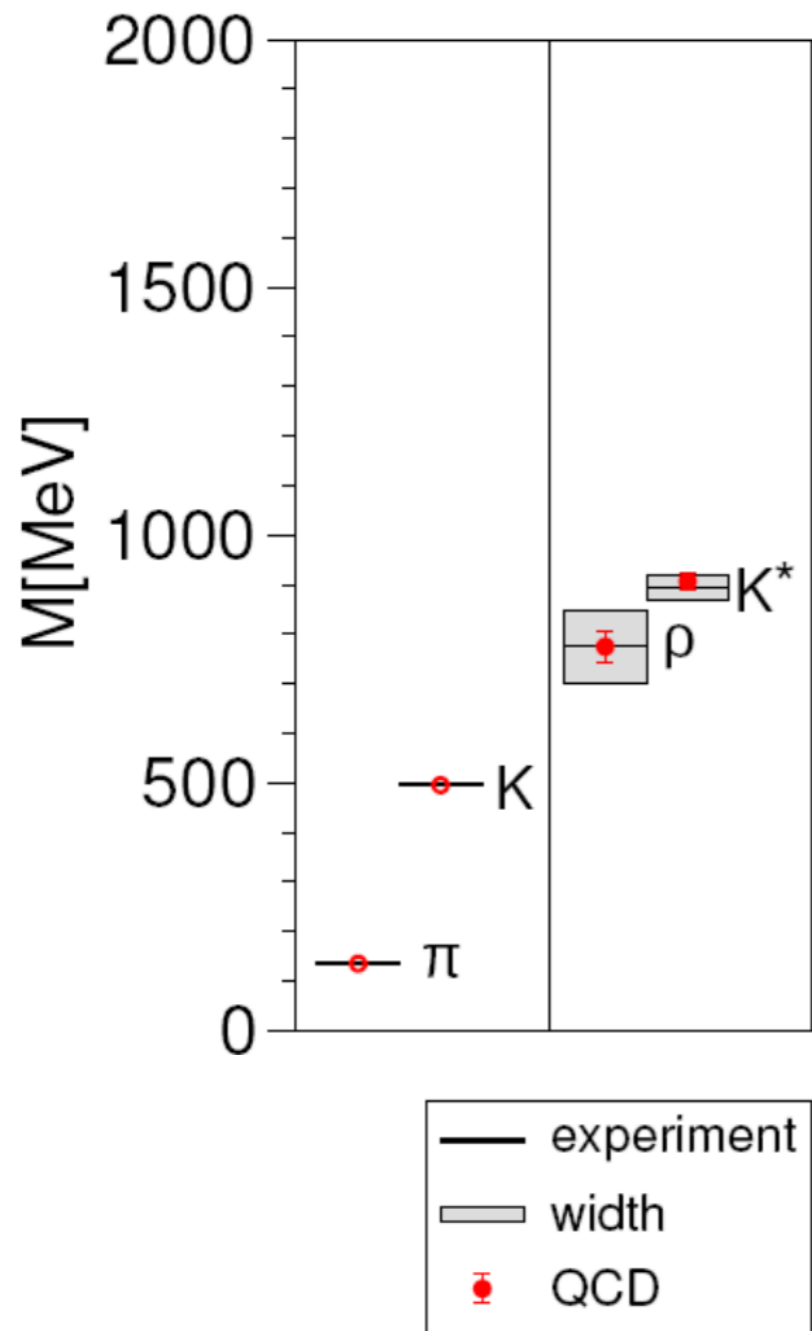

$$\vec{J} = \vec{L} + \vec{S}$$

$$P = (-1)^{L+1}$$

$$C = (-1)^{L+S}$$

* Allowed J^{PC} for $q\bar{q}$ mesons:

$$J^{PC} = 0^{-+}, 1^{--}, 1^{+-}, 0^{++}, 2^{++} \dots$$

Hybrid mesons and gluonic excitations

- * Excited gluonic field coupled to $q\bar{q}$ pair
- * Rich spectrum of hybrid mesons predicted by Lattice QCD
- * Gluonic field with $J^{PC} = 1^{+-}$ and mass = 1-1.5 GeV

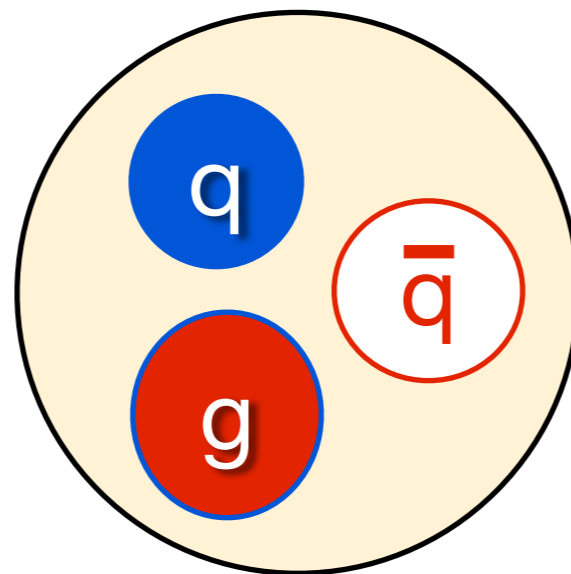

hybrid meson

Hybrid mesons and gluonic excitations

- * Excited gluonic field coupled to $q\bar{q}$ pair
- * Rich spectrum of hybrid mesons predicted by Lattice QCD
- * Gluonic field with $J^{PC} = 1^{+-}$ and mass = 1-1.5 GeV
- * “Exotic” J^{PC} : not simple $q\bar{q}$ from the non-rel. quark model

$$J^{PC} = 0^{+-}, 1^{-+}, 2^{+-} \dots$$

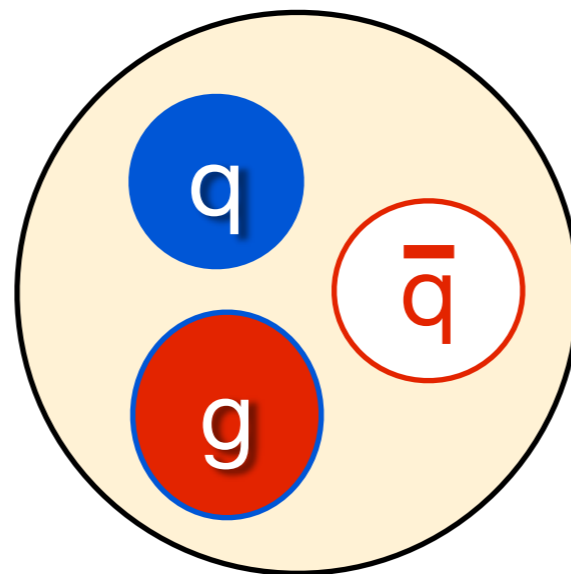

hybrid meson

$$\begin{aligned} \vec{J} &= \vec{L} + \vec{S} \\ P &= (-1)^{L+1} \\ C &= (-1)^{L+S} \end{aligned}$$

Lattice QCD

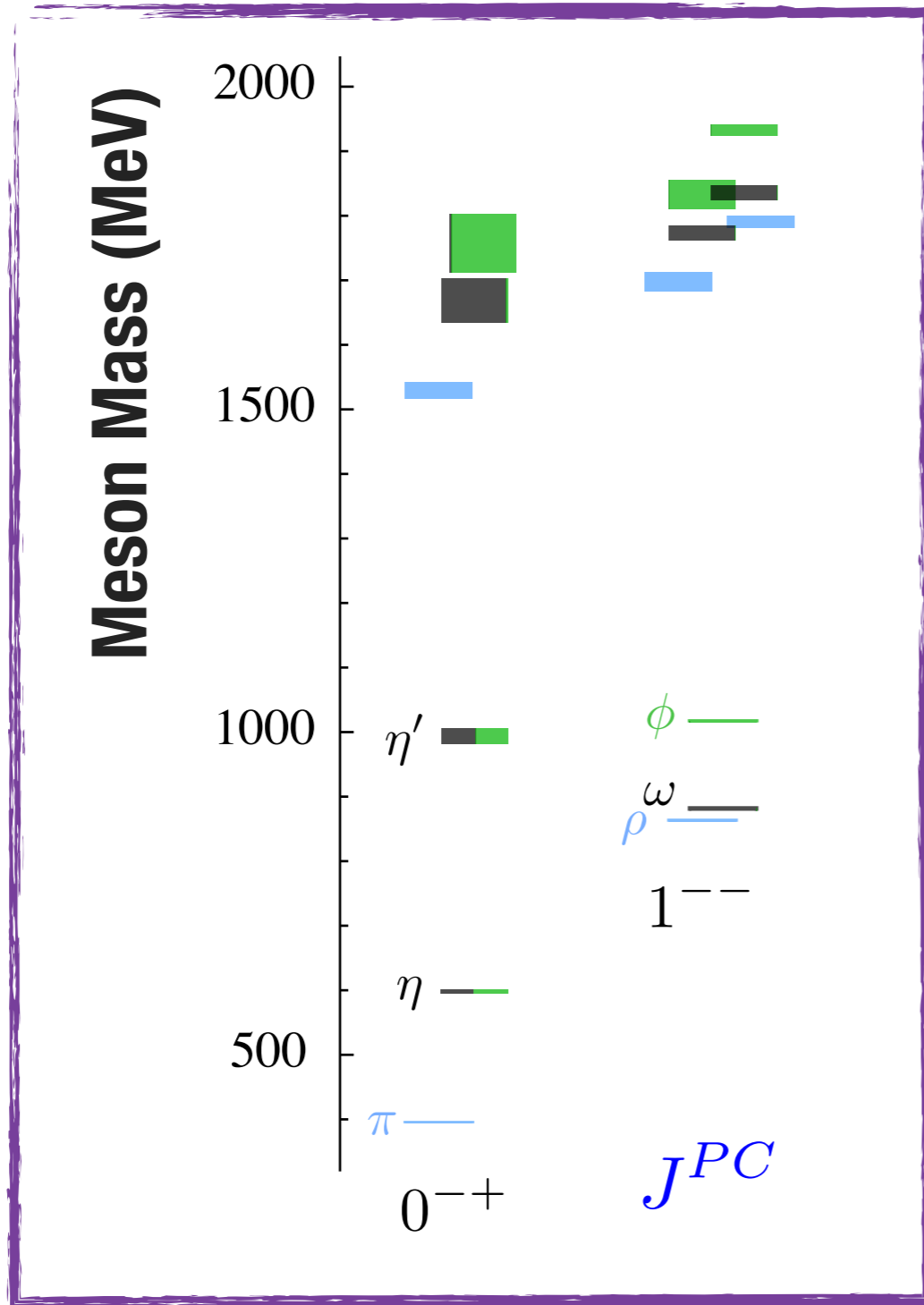

$$u\bar{u} + d\bar{d} \quad \blacksquare$$

$$s\bar{s} \quad \blacksquare$$

$$\phi = |s\bar{s}\rangle$$

$$\omega = |u\bar{u} + d\bar{d}\rangle$$

$$\pi^0 = |u\bar{u} - d\bar{d}\rangle$$

Note: $m_\pi = 392 \text{ MeV}$

Lattice QCD

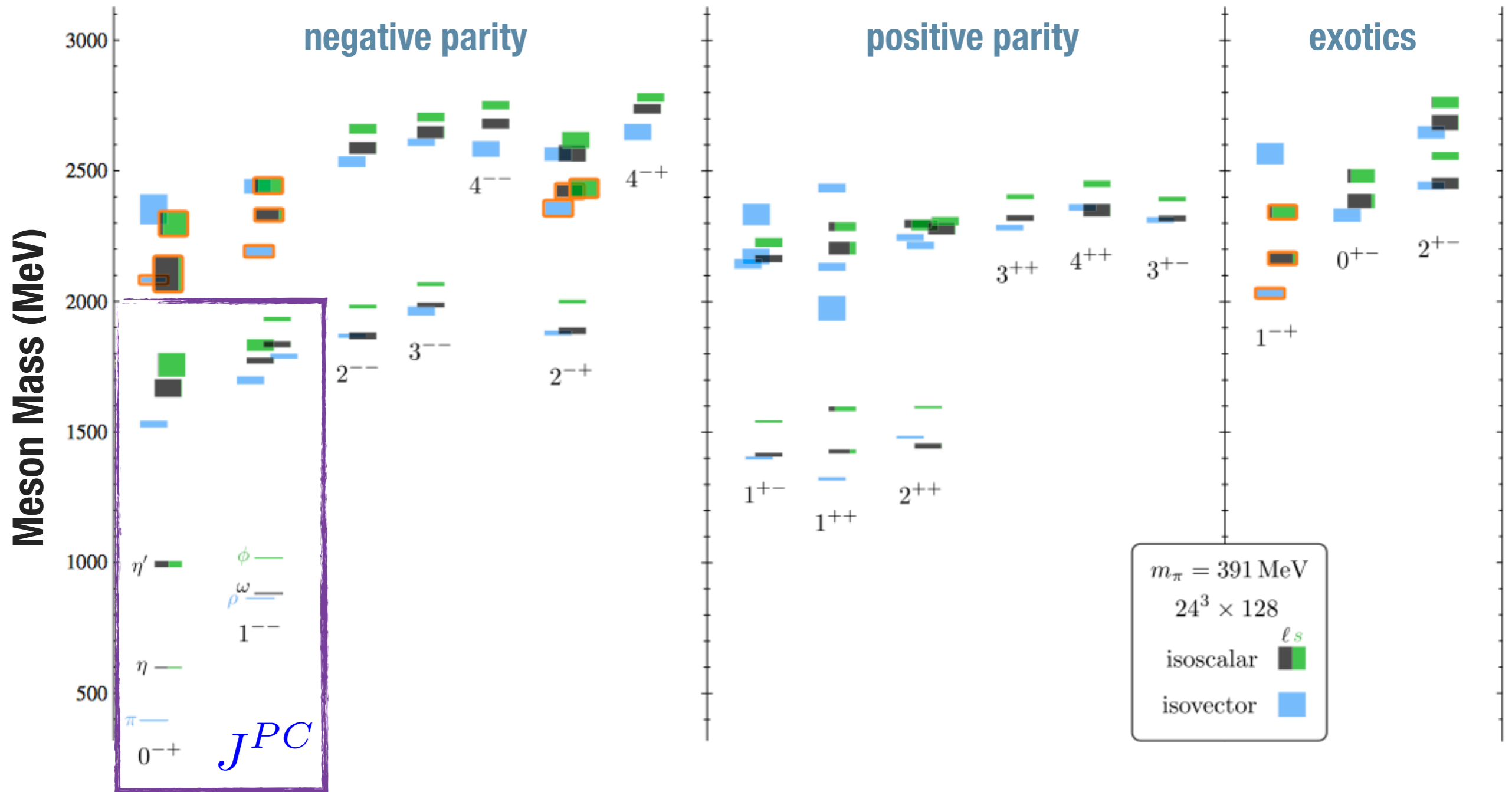

Lattice QCD

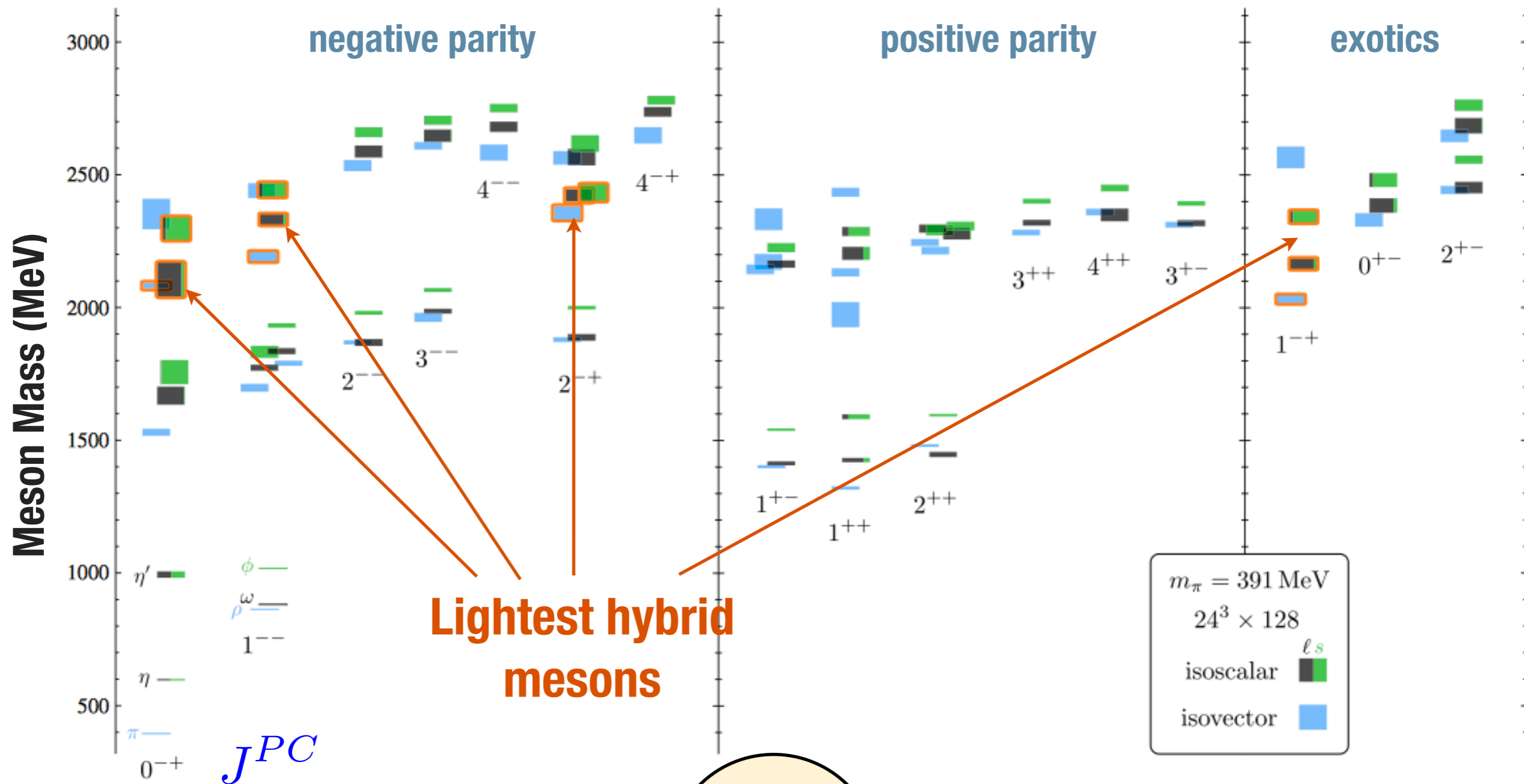



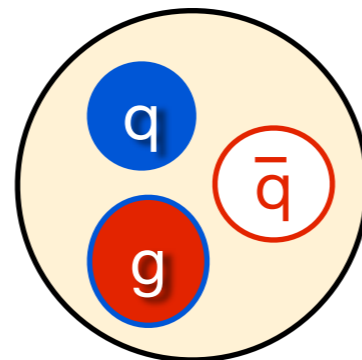
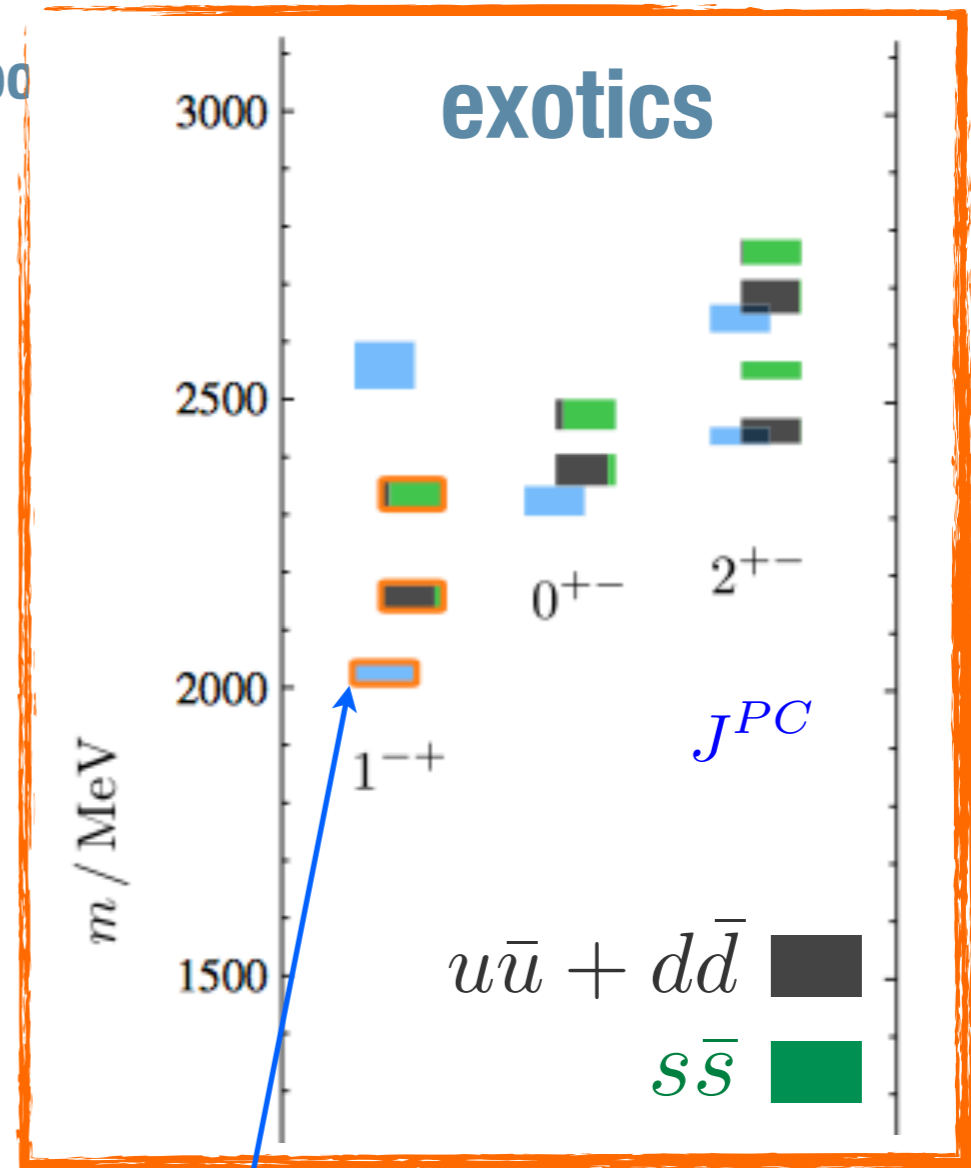
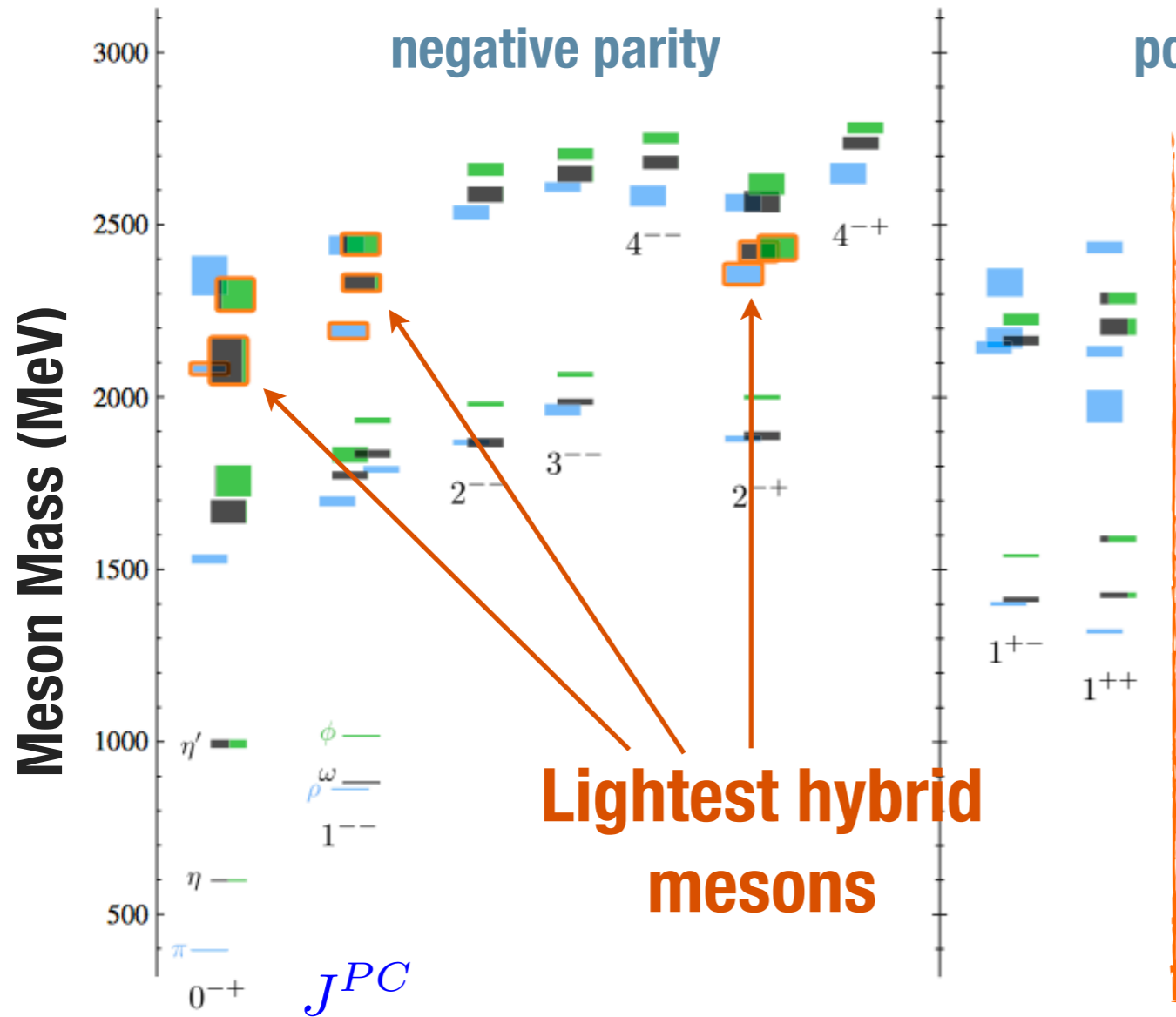











Lattice QCD



Most experimental searches for hybrids limited to the π_1 state

Light quark experiments

	Heavy quarks	Light quarks
Electromagnetic probes	e^+e^-    	γp   
Hadronic probes	$\bar{p}p$   pp   	$\bar{p}p$  πp 

Compass: Diffractive πp scattering

- * Long history of hadron spectroscopy in pion production experiments
- * Rich structure in $\pi^-\pi^+\pi^-$ spectrum, modeled as intermediate resonances X^- and $\pi^+\pi^-$ **Isobars**

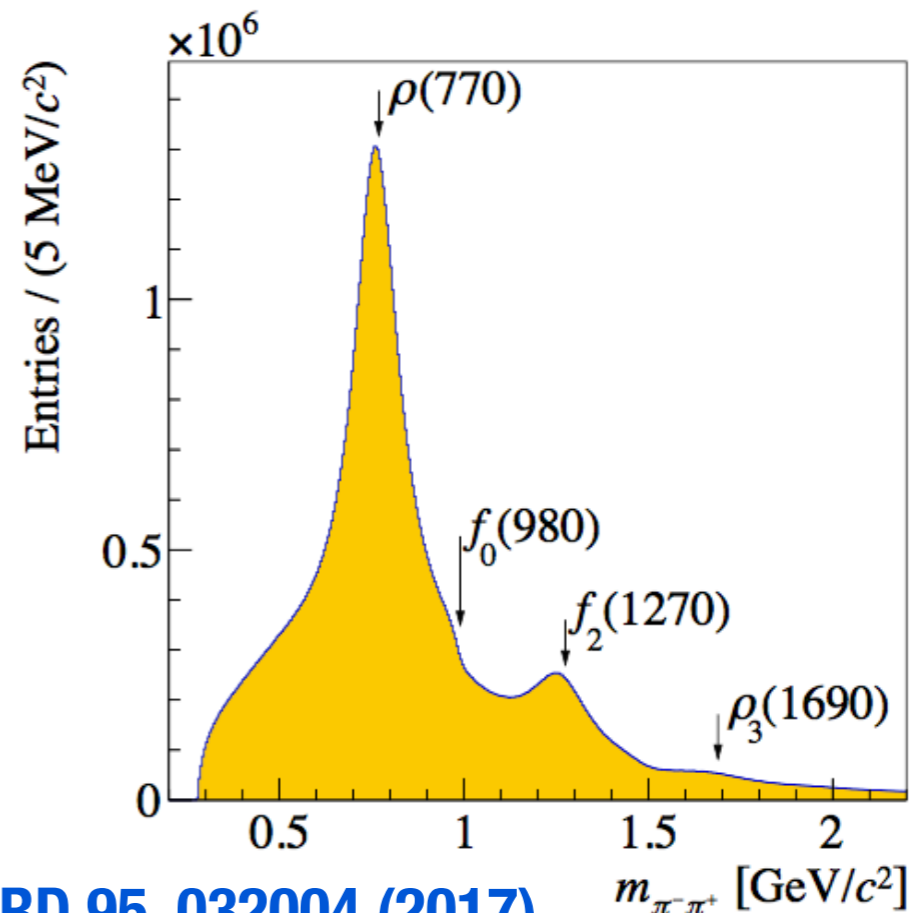
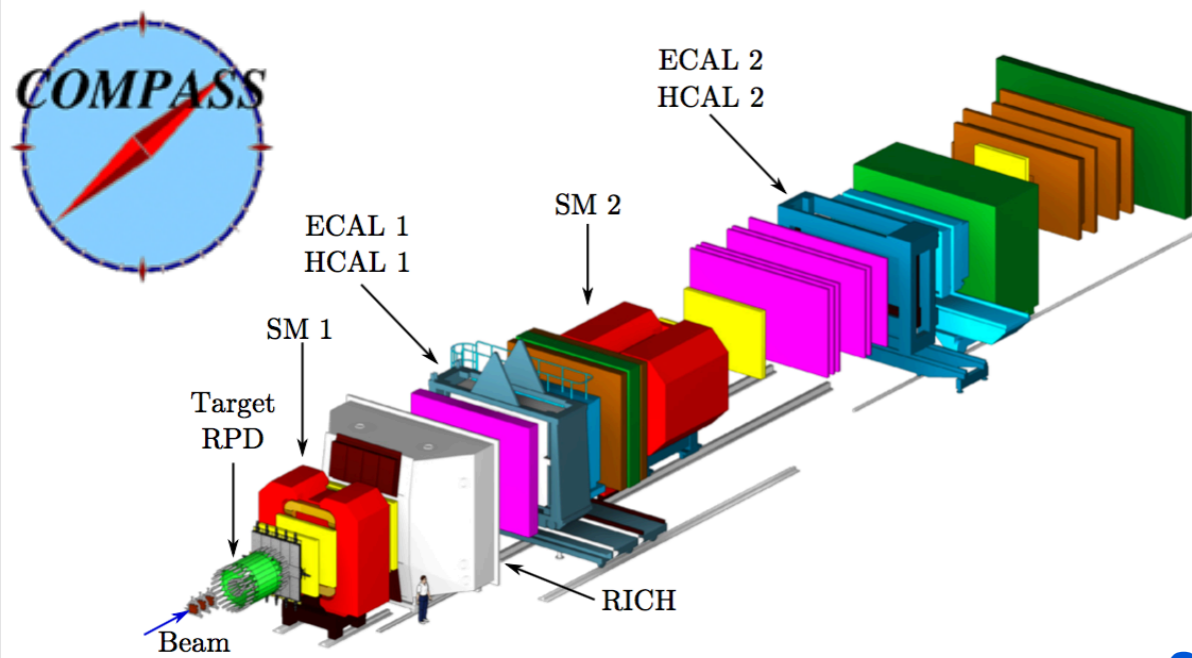
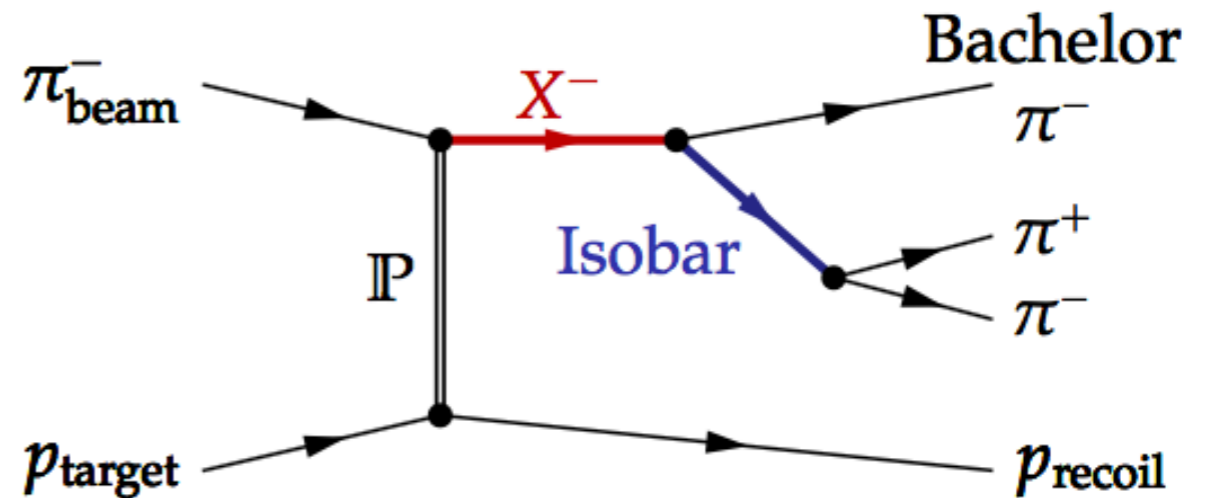

Compass: PRD 95, 032004 (2017)

Compass: Diffractive πp scattering

- * Long history of hadron spectroscopy in pion production experiments
- * Rich structure in $\pi^-\pi^+\pi^-$ spectrum, modeled as intermediate resonances X^- and $\pi^+\pi^-$ **Isobars**

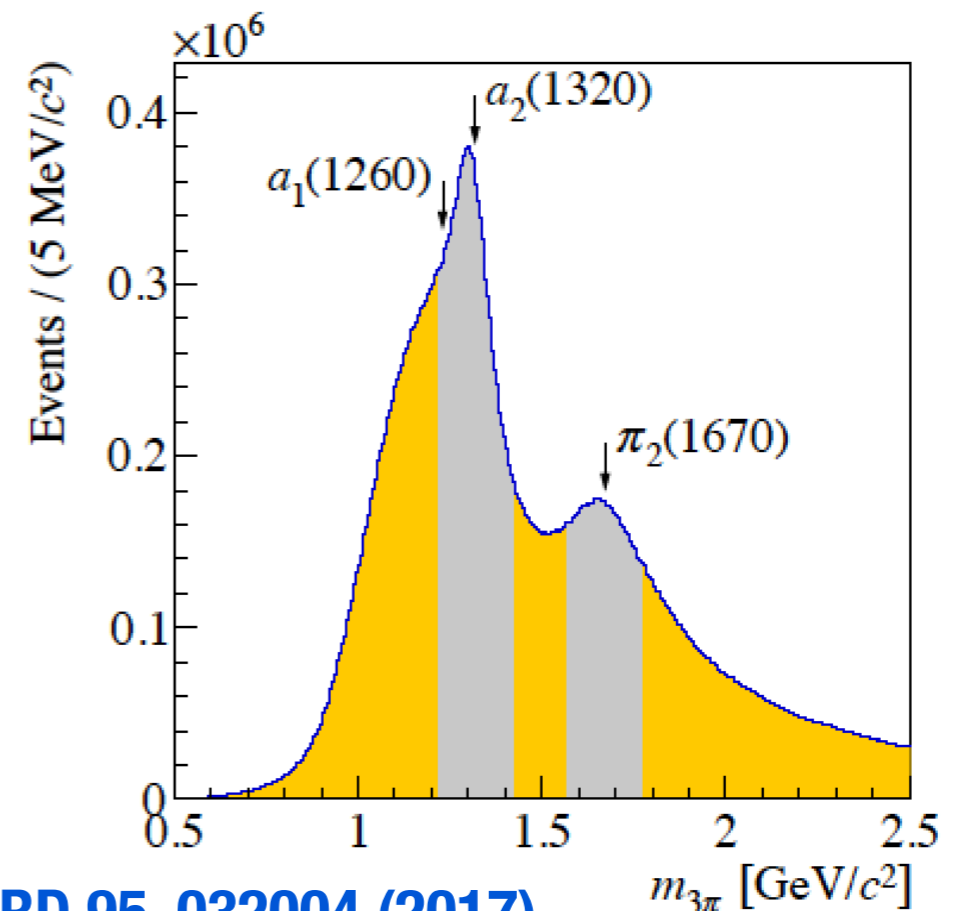
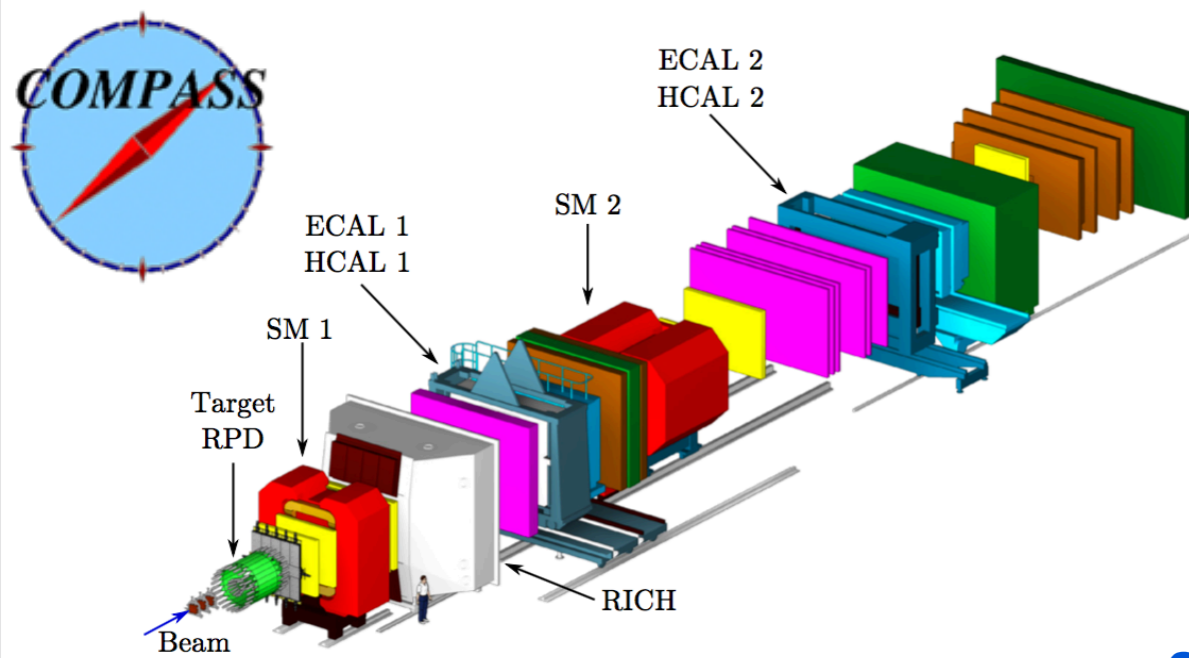
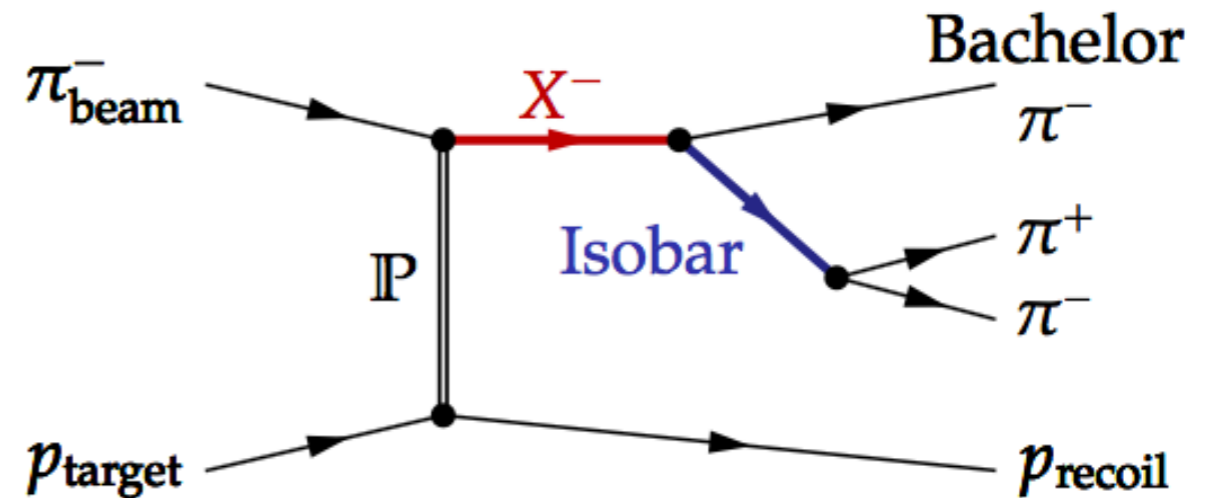

Compass: PRD 95, 032004 (2017)

Double Slit Experiment

Step 1: Shoot particles at slits

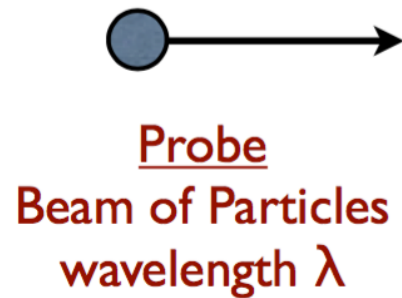

Goal: determine the values of d and D

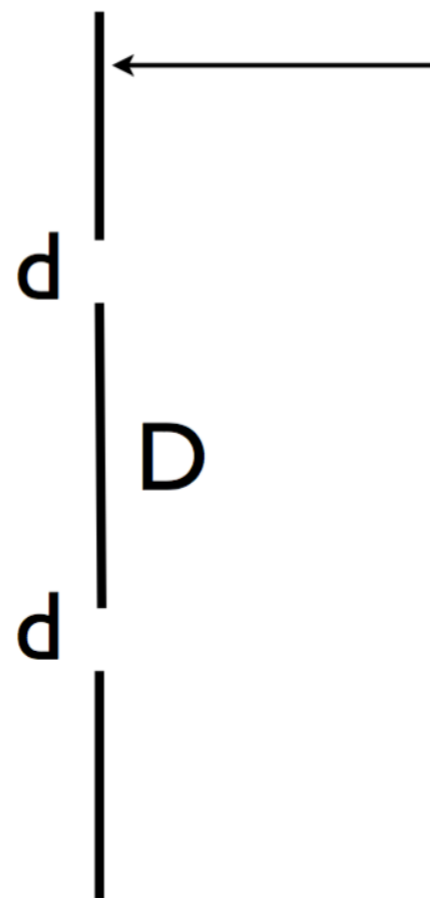

Physical System Under Study
Two Slits: width d , separation D

Step 2: For each particle record location x where it was detected

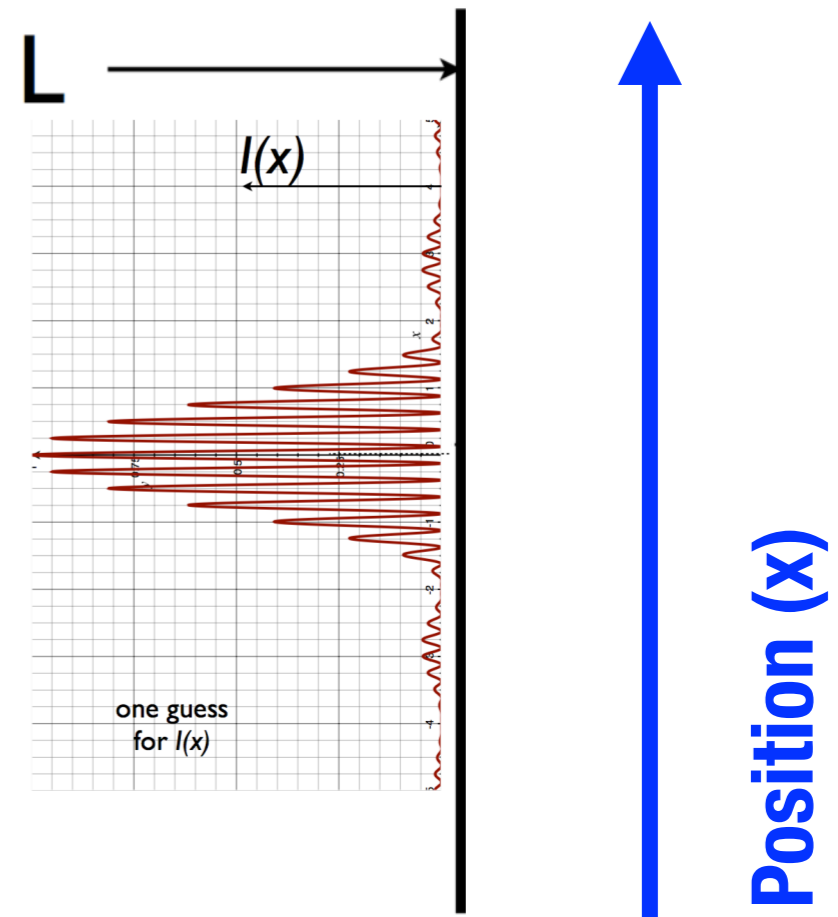

Detector
Measures location x_i for each arriving particle

Physical Model:

$$I(x) = I_0 \left(\frac{\sin(d\pi x / \lambda L)}{d\pi x / \lambda L} \right)^2 \cos^2(2D\pi x / \lambda L)$$

Particle physics “many slits”

Step 1: Create particles **a**, **b** and **c** in some collision

Probe: particles **a**, **b** and **c** which can form heavier particles **X**, **Y** or **Z**

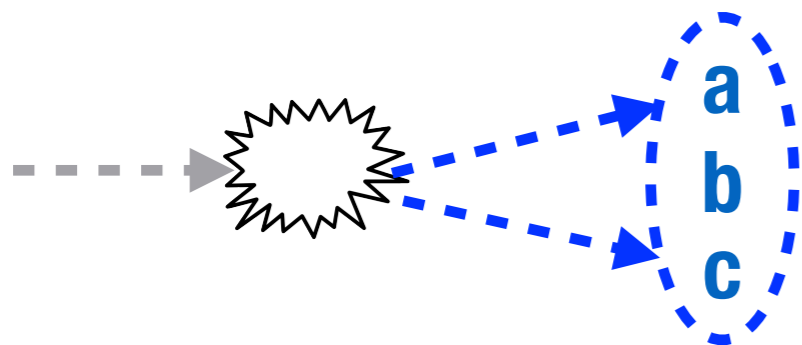

Physical Model:

$$I(M) = \left| \sum_{i=X,Y,Z} V_i A_i(M) \right|^2$$

Goal: determine properties of X, Y, and Z

Physical System Under Study: intermediate particles X, Y, and Z

**Intermediate
Particles**

Z

Y

X

Step 2: For each collision record the **mass of the abc system**

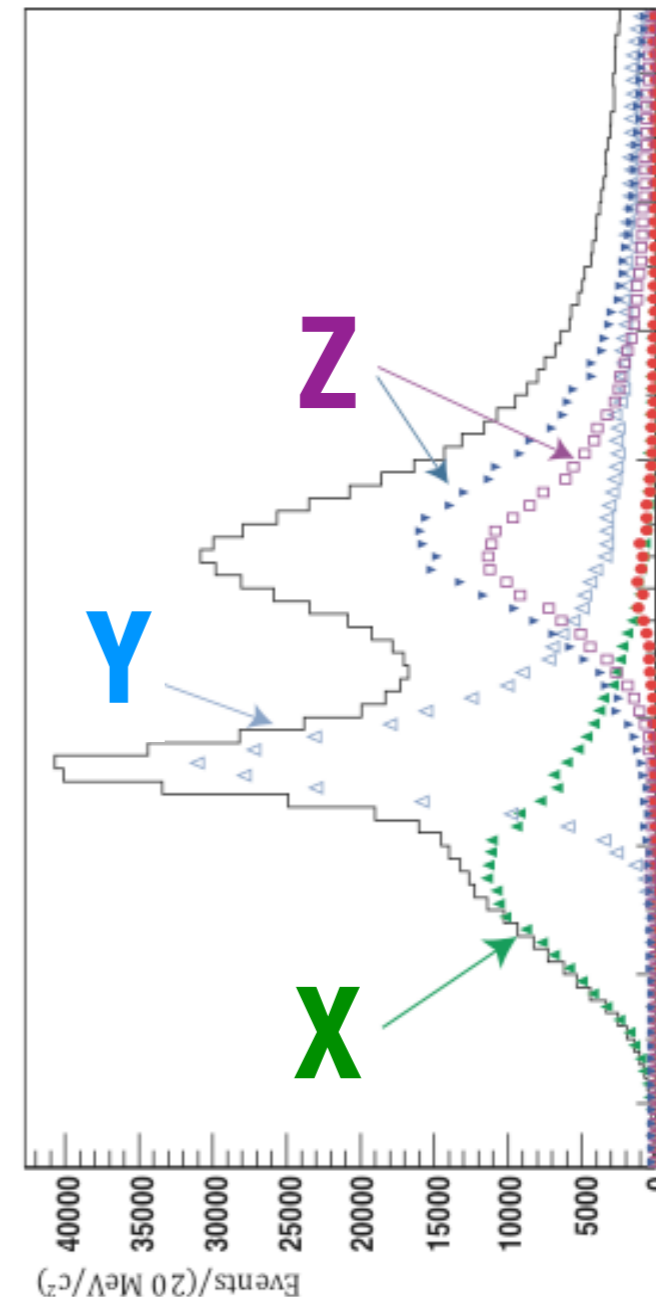

Detector: Measure mass of abc system for each collision

Amplitude Analysis

* **Goal:** Identify J^{PC} of $X \rightarrow \pi^+\pi^-\pi^+$

* Model the intensity of events at the level of QM amplitudes (allow for interference)

$$I(\vec{x}) = \frac{dN}{d\vec{x}} = \left| \sum_{\alpha} V_{\alpha} A_{\alpha}(\vec{x}) \right|^2$$

* 5-dimensional problem: two new angles at each decay step (X and I)

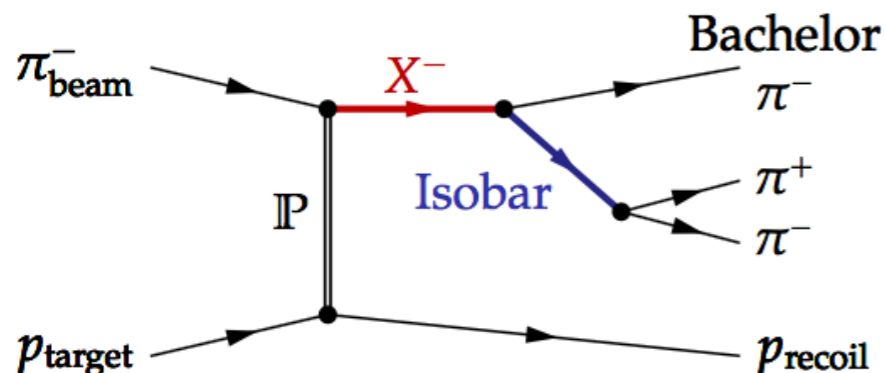

Example Intensity:

$X(1^{++}) \rightarrow \rho\pi^+$ (S wave)

$X \rightarrow \rho\pi^+$

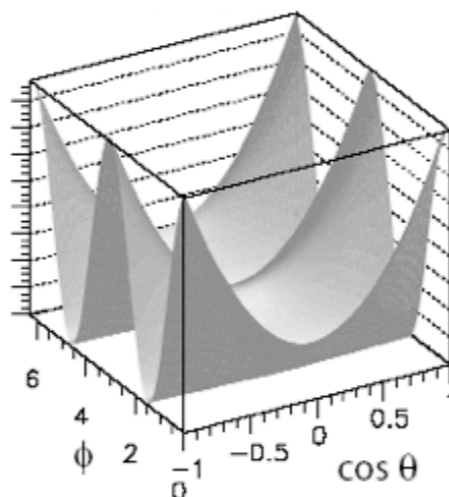

$\rho \rightarrow \pi^+\pi^-$

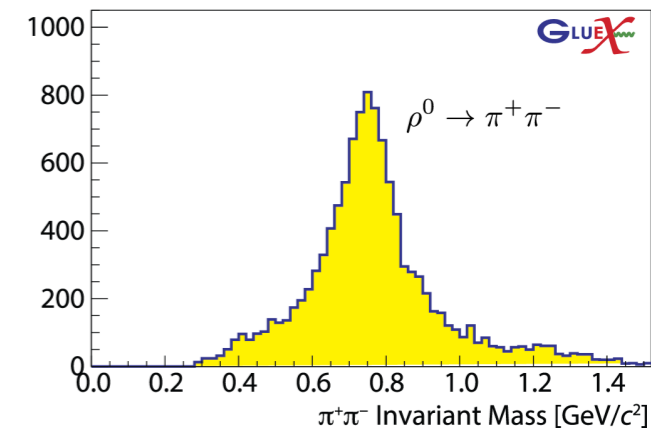
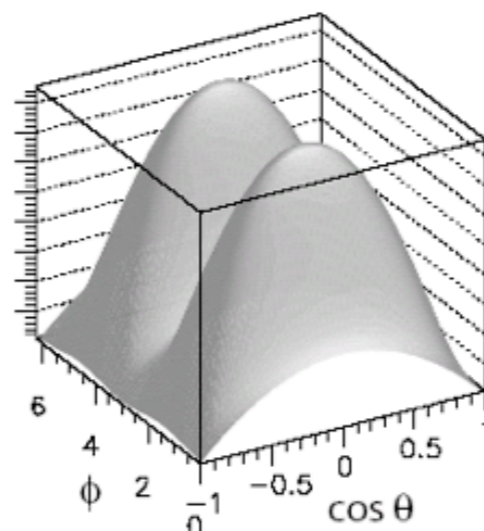

Amplitude Analysis

$$I(\vec{x}) = \frac{dN}{d\vec{x}} = \left| \sum_{\alpha}^{N_{\text{amps}}} V_{\alpha} A_{\alpha}(\vec{x}) \right|^2$$

- * Expand set of possible amplitudes over many X and I , and determine V_{α} via maximum likelihood fit
- * Good angular acceptance critical for disentangling J^{PC}

Example Intensities:

$$X(1^{++}) \rightarrow \rho\pi^{+} \text{ (S wave)}$$

$$X(2^{++}) \rightarrow \rho\pi^{+} \text{ (D wave)}$$

$$X \rightarrow \rho\pi^{+}$$

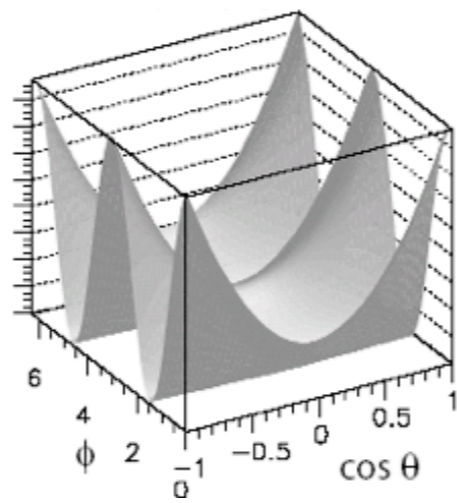

$$\rho \rightarrow \pi^{+}\pi^{-}$$

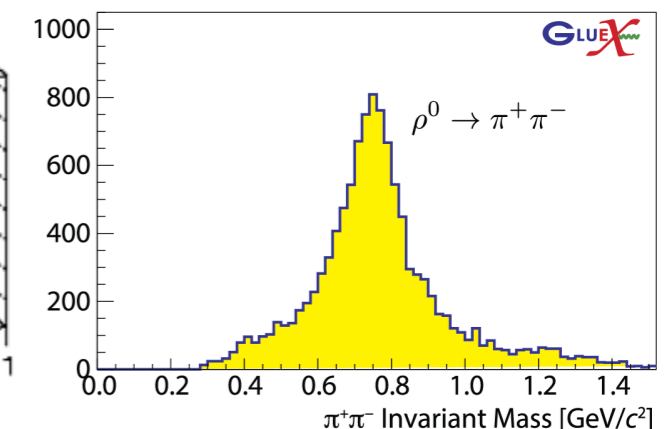
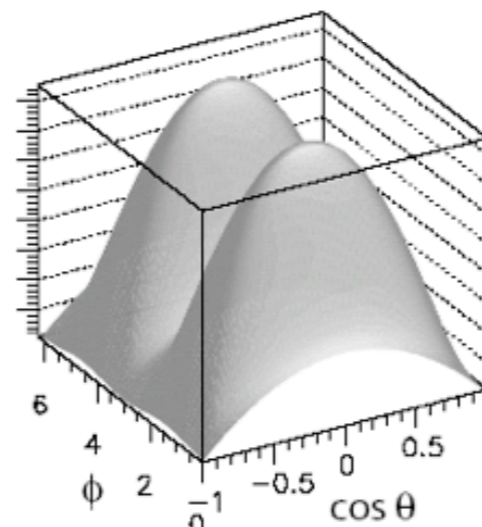
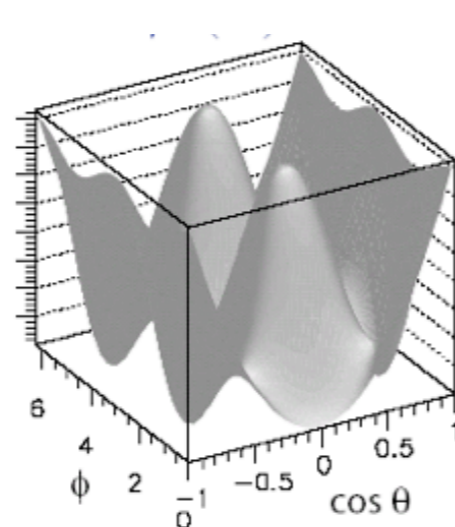
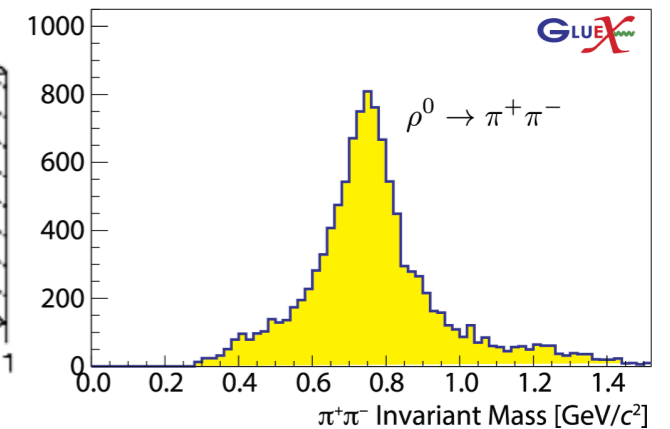
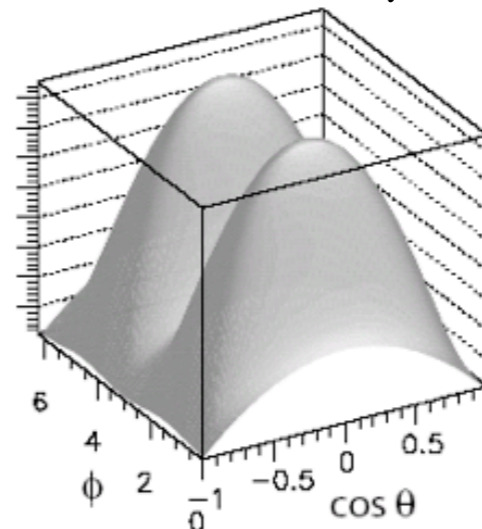

Early evidence for 1^{-+} exotics: $\pi_1(1600)$

COMPASS: $\pi^{-} p \rightarrow \pi^{-} \pi^{+} \pi^{-} p$

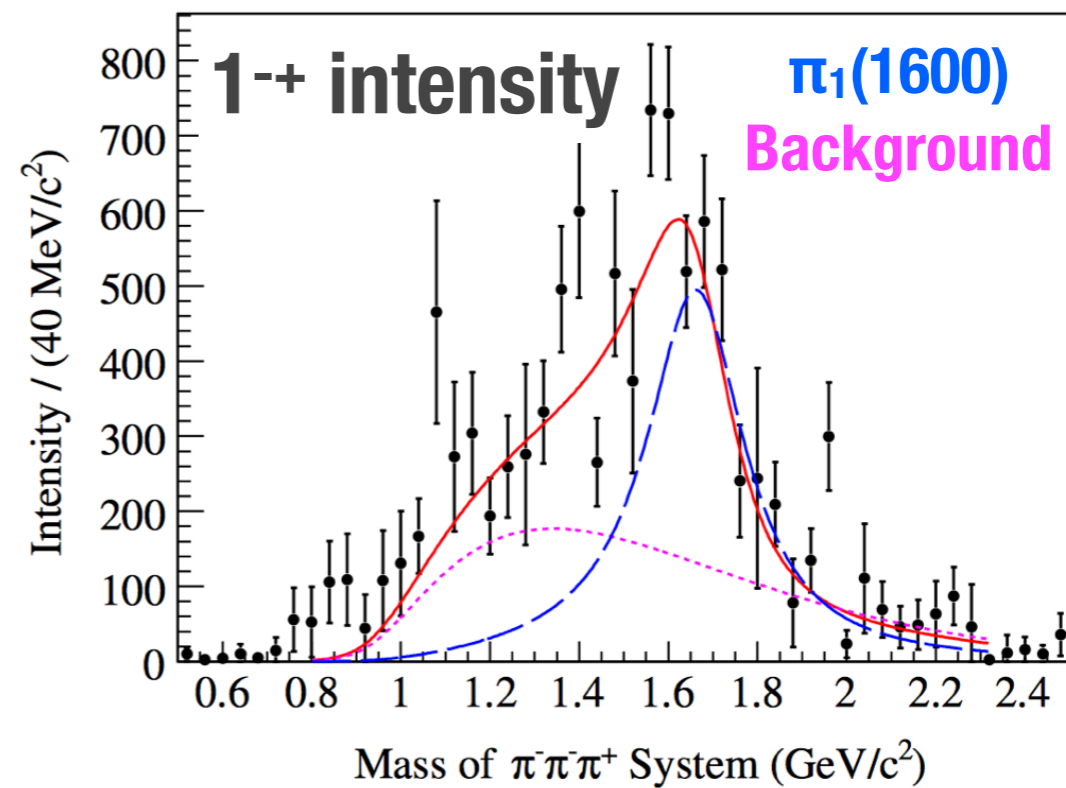
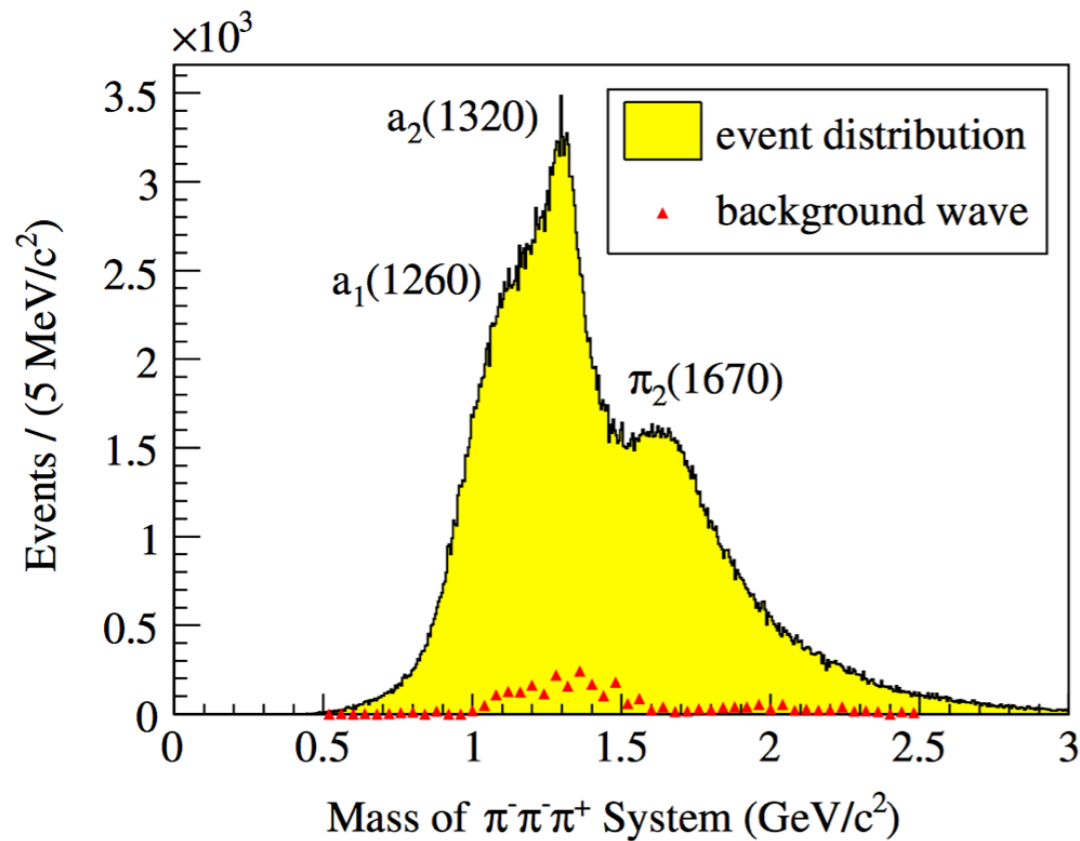

PRL 104, 241803 (2010)

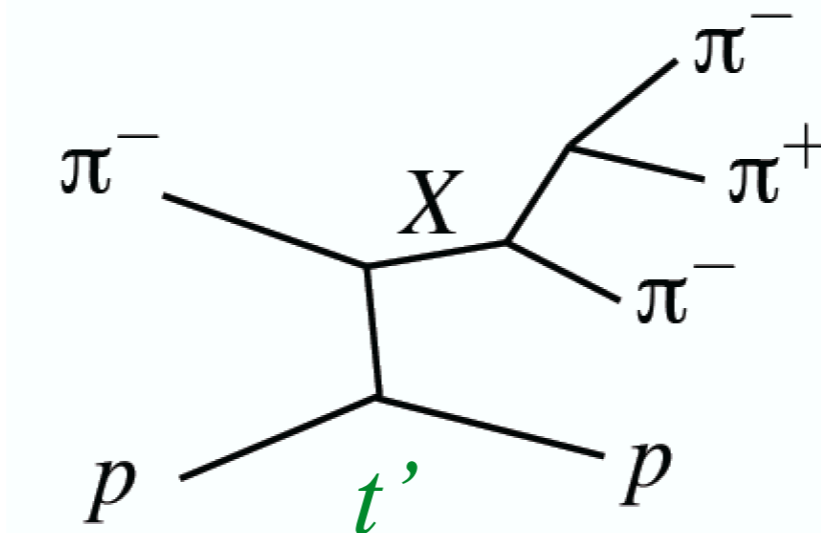

Compass $\pi\rho$ amplitude analysis

Compass: PRL 104, 241803 (2010)

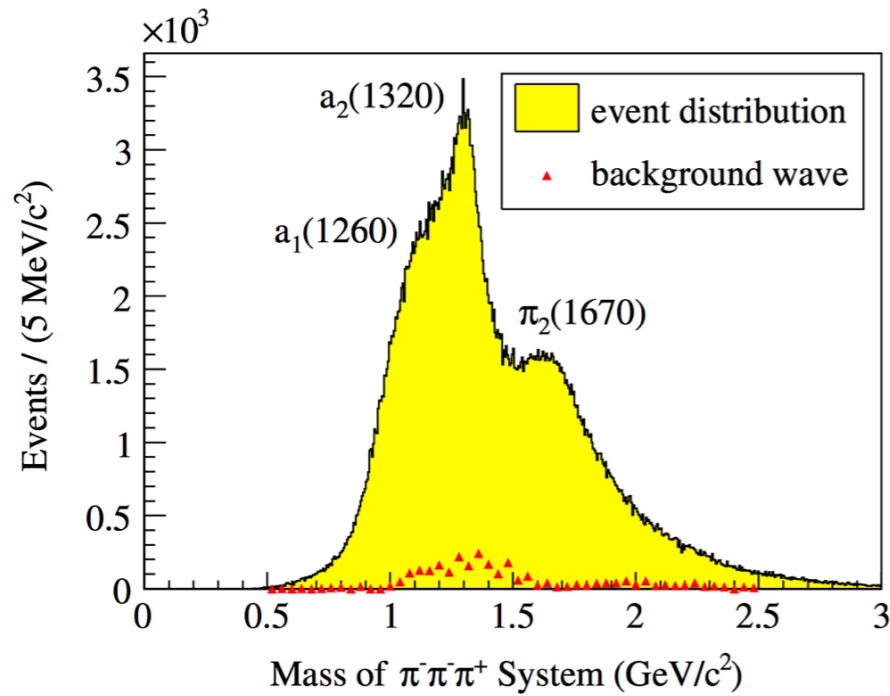

Unprecedented statistics:
 →
 ~50M exclusive events

Compass: PRD 95, 032004 (2017)

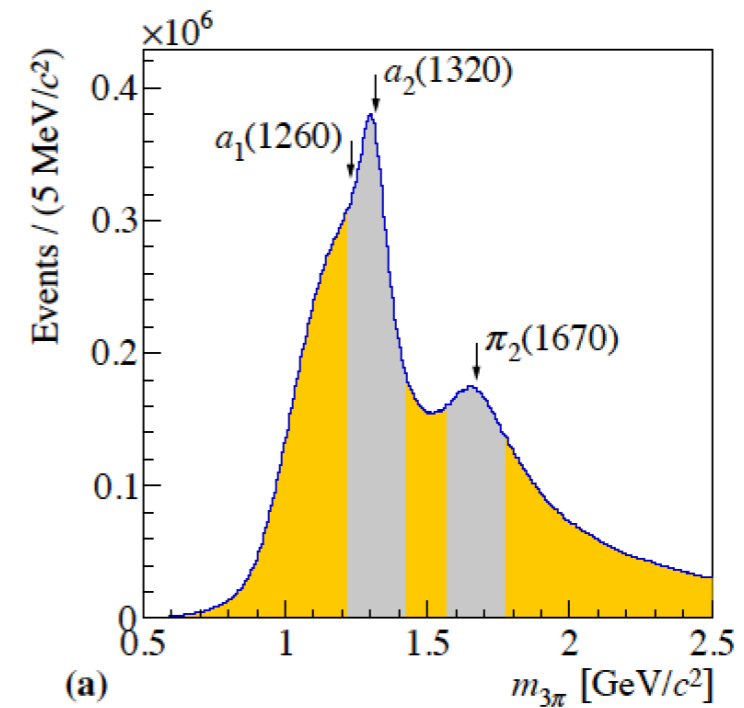

(a)

- ✱ Decompose into 88 amplitudes representing **X**-, **Isobars**, **L**, and **M**



- ✱ Extract amplitude intensity and phase in bins of $\pi^-\pi^+\pi^-$ mass

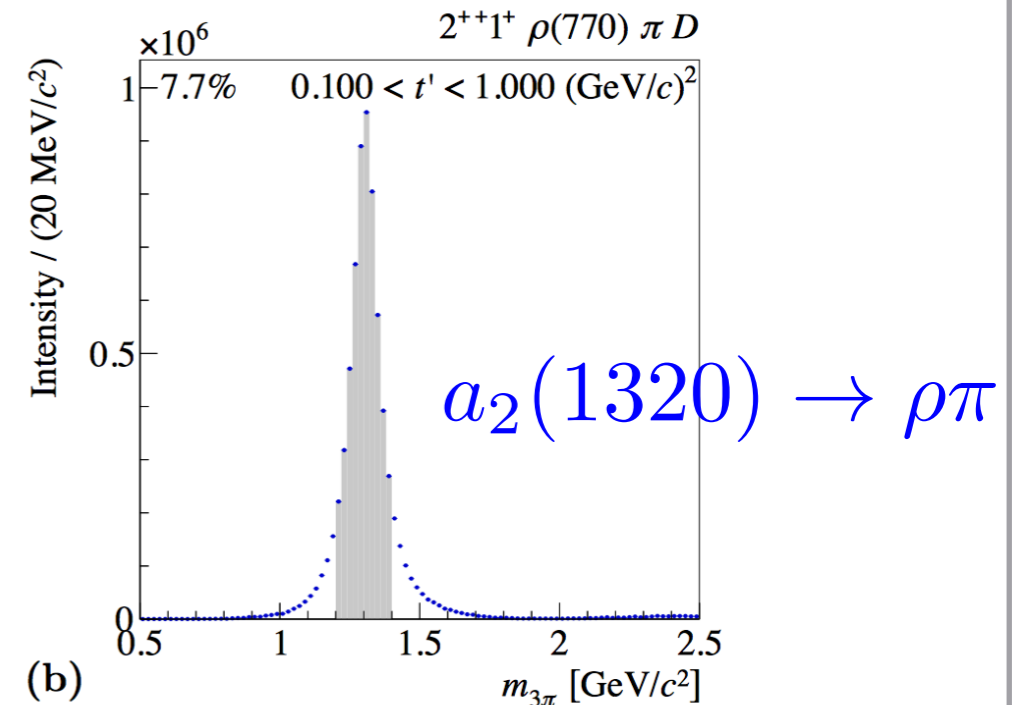

(b)

Compass $\pi\rho$ amplitude analysis

Compass: PRL 104, 241803 (2010)

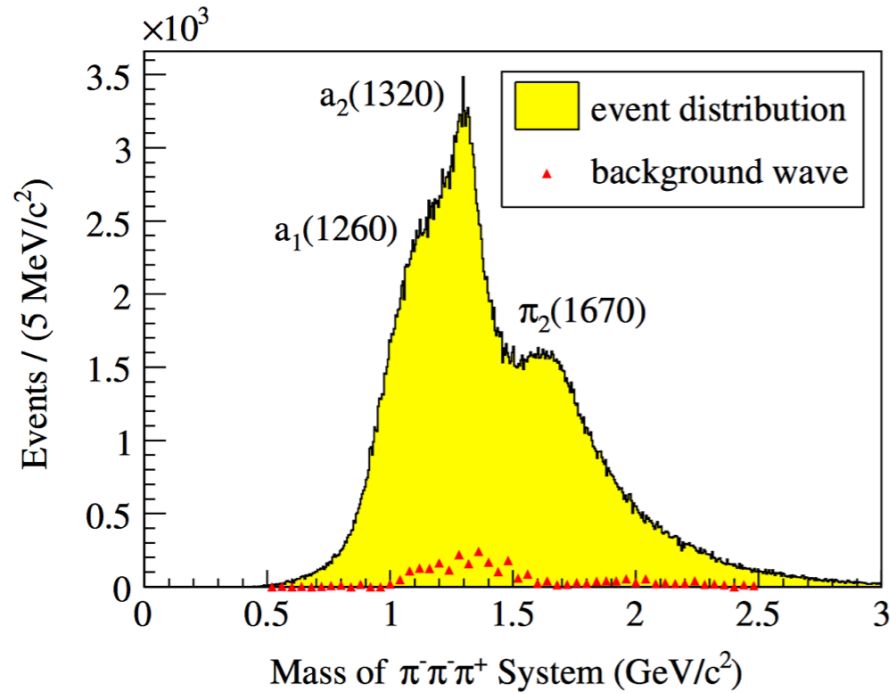

Unprecedented statistics:
 →
 ~50M exclusive events

Compass: PRD 95, 032004 (2017)

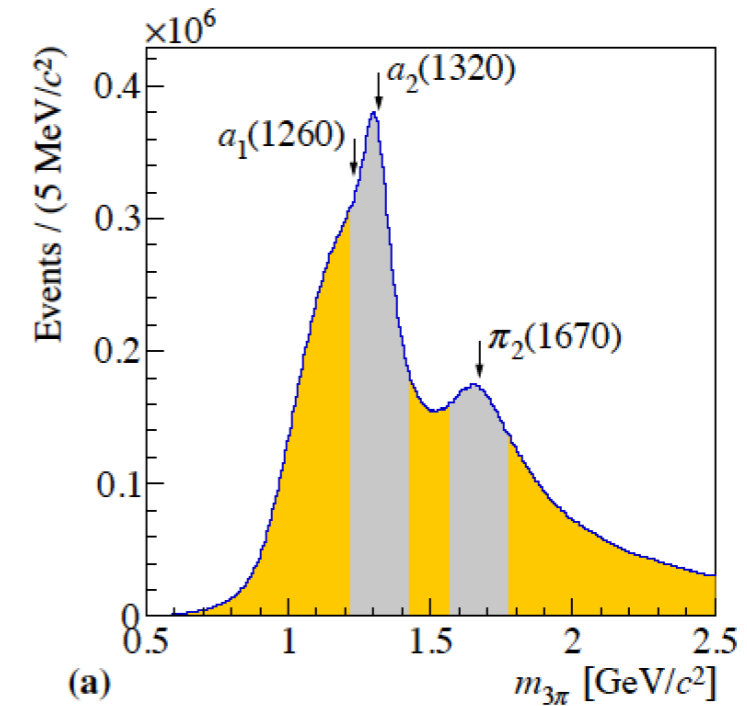

(a)

- ✱ Decompose into 88 amplitudes representing **X**-, **Isobars**, **L**, and **M**

- ✱ Extract amplitude intensity and phase in bins of $\pi^-\pi^+\pi^-$ mass

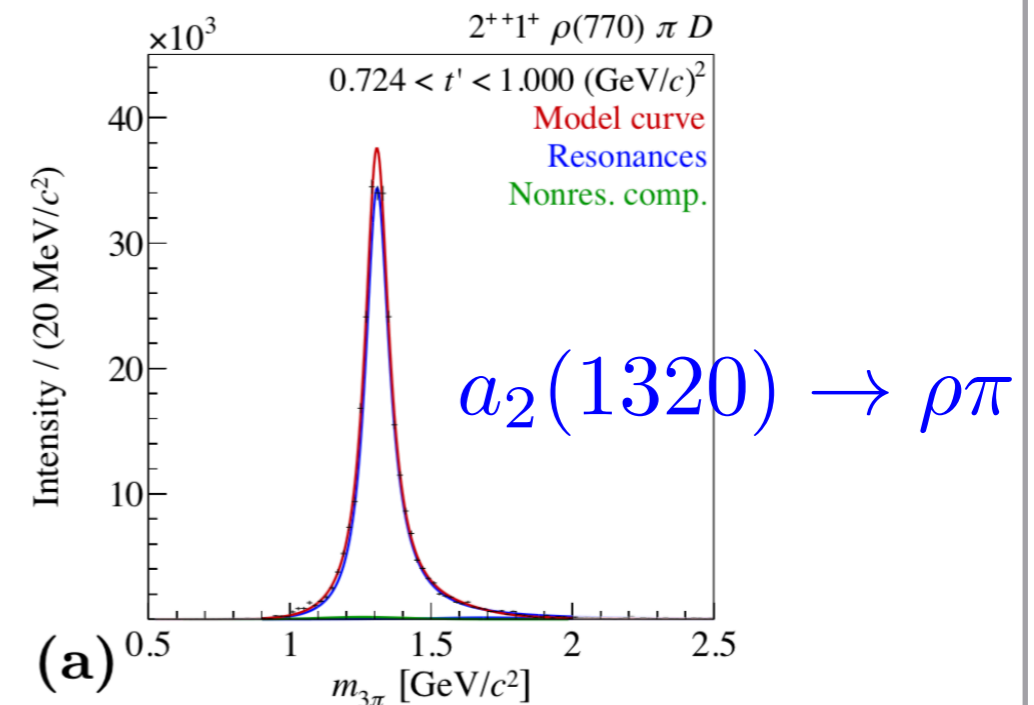

(a)

Compass $\pi\rho$: example amplitudes

$$X(1^{++})$$

$\rightarrow \rho\pi^-$ (S wave)

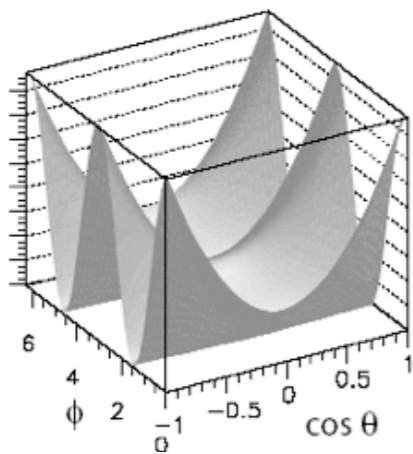

$$X(2^{++})$$

$\rightarrow \rho\pi^-$ (D wave)

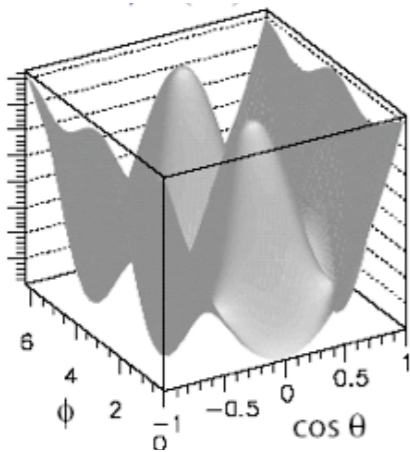

arXiv:1802.05913

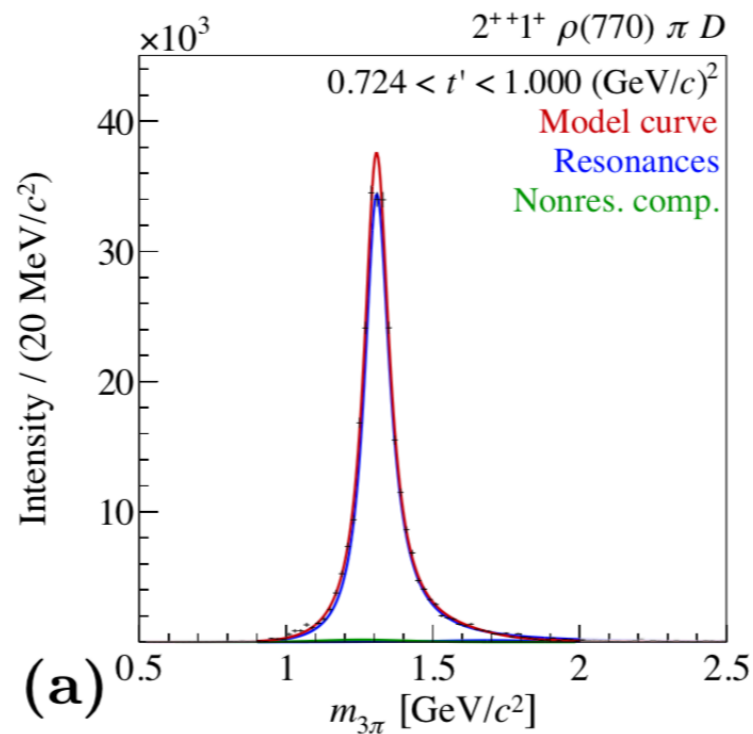
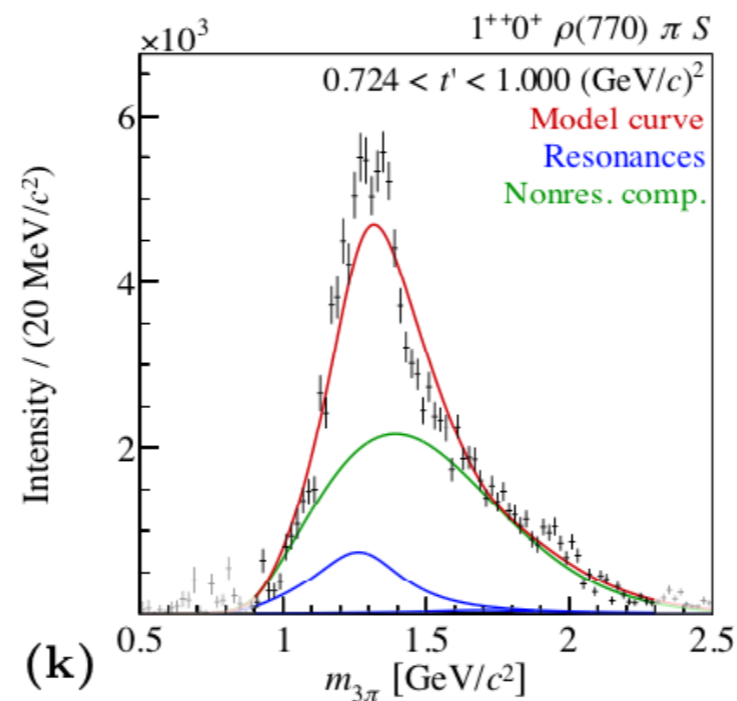

Interference

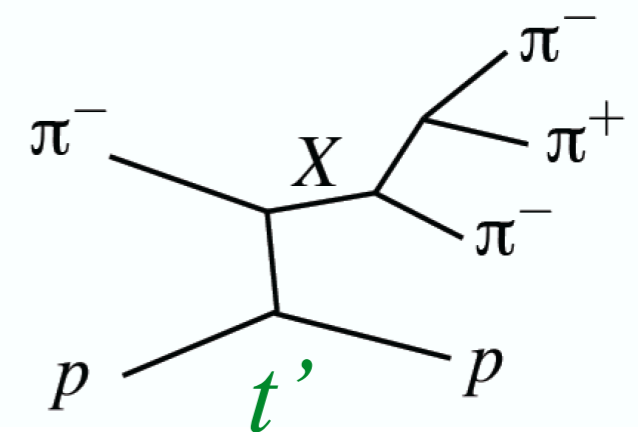
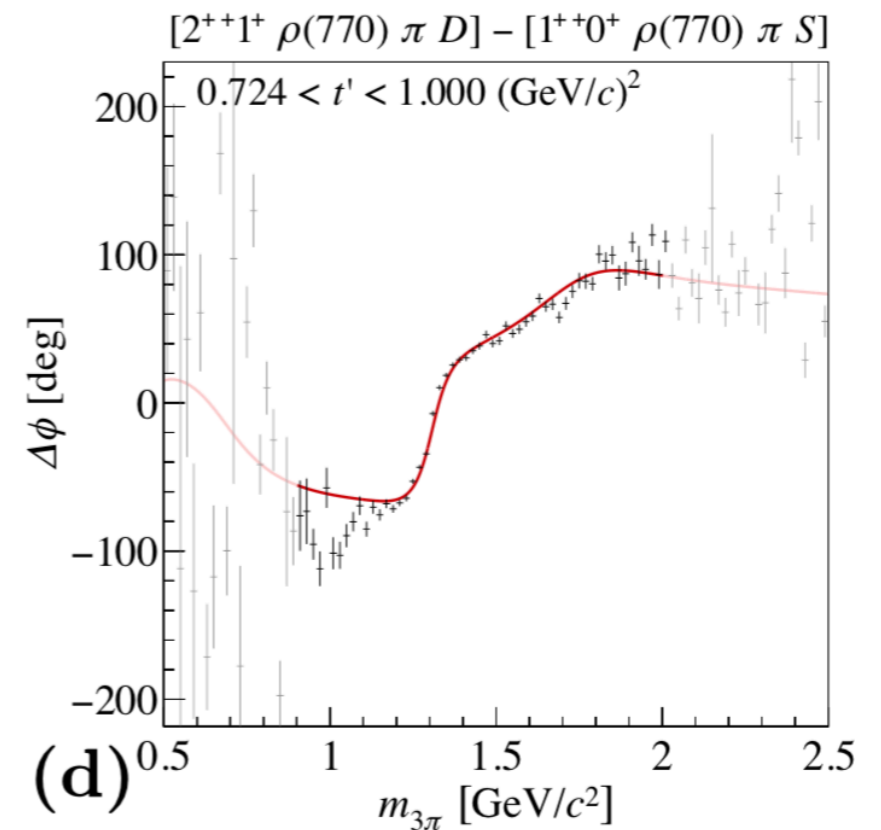

Compass $\pi\rho$ amplitude analysis

1992

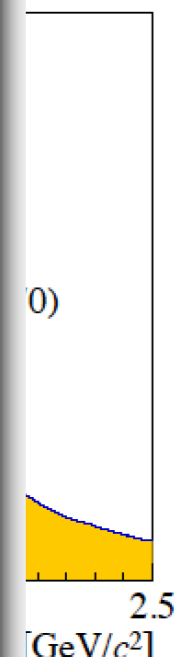

$(170) \pi D$
[GeV/c²]

1320) $\rightarrow \rho\pi$

Compass

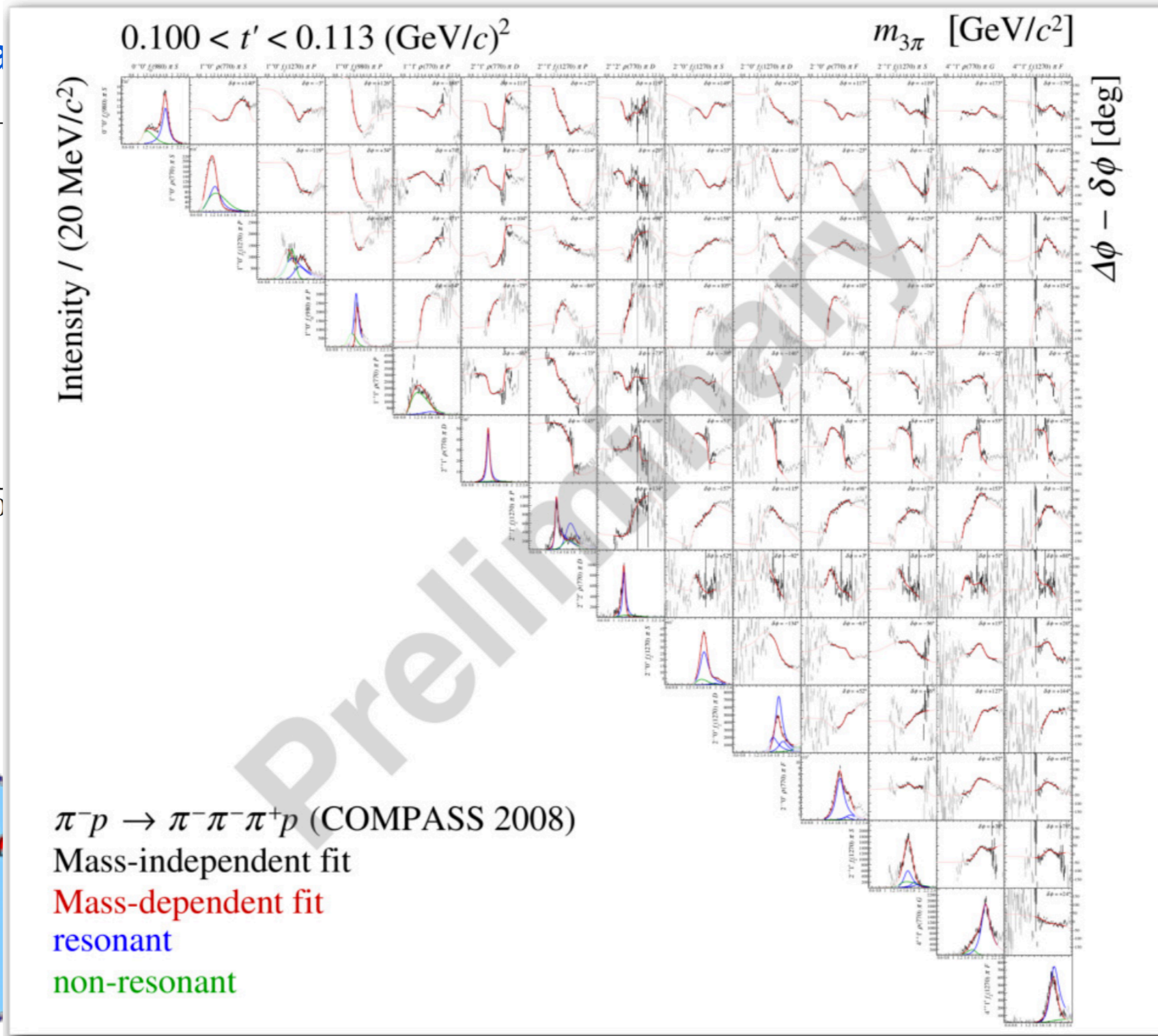
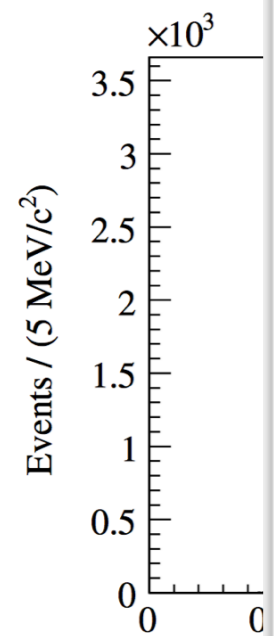

$\pi^- p \rightarrow \pi^- \pi^- \pi^+ p$ (COMPASS 2008)
 Mass-independent fit
 Mass-dependent fit
 resonant
 non-resonant

(b) $m_{3\pi}$ [GeV/c²]



Compass πp amplitude analysis

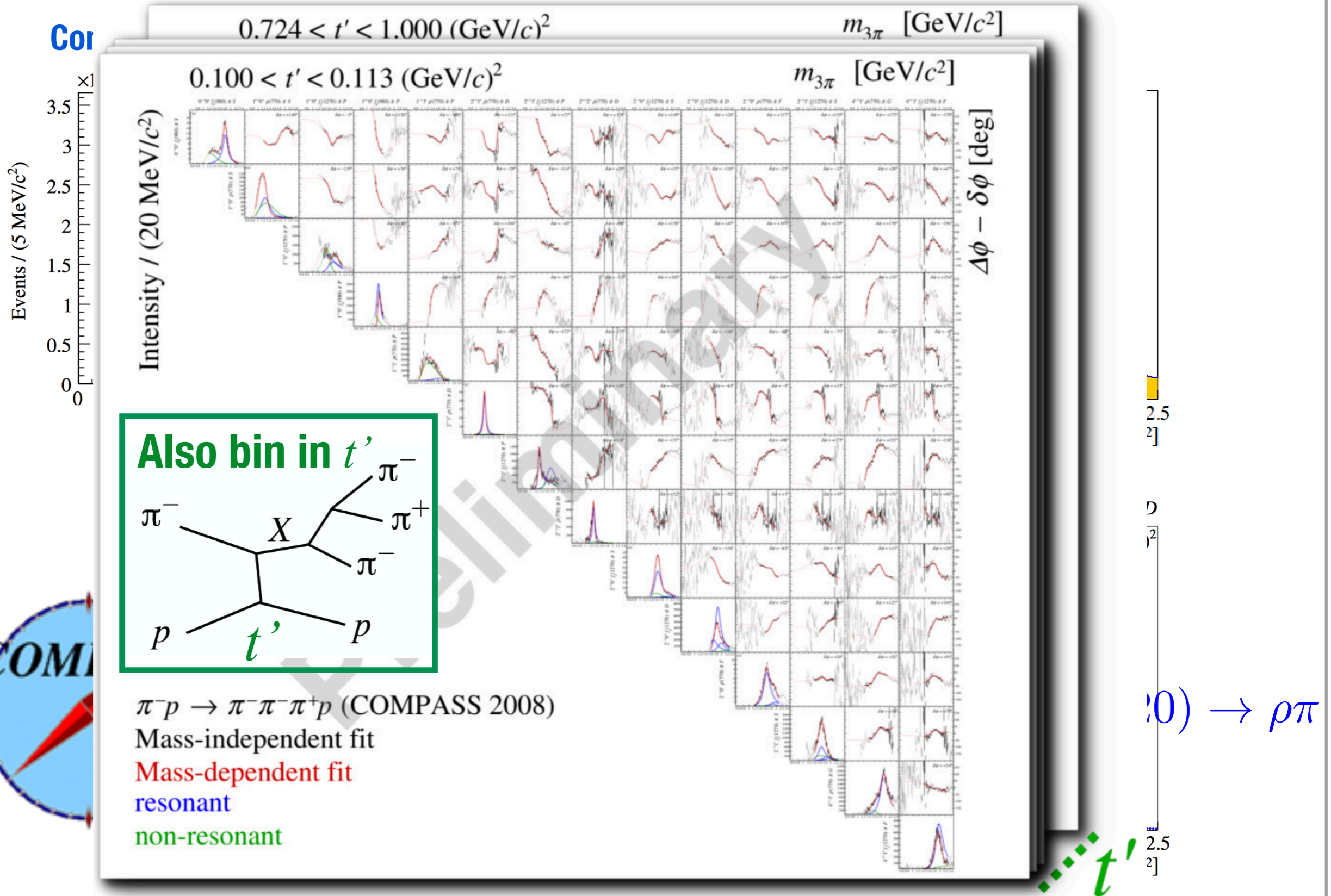

Evidence for $1^{-+} \pi_1(1600)$ in $\rho\pi$

Low t'

High t'

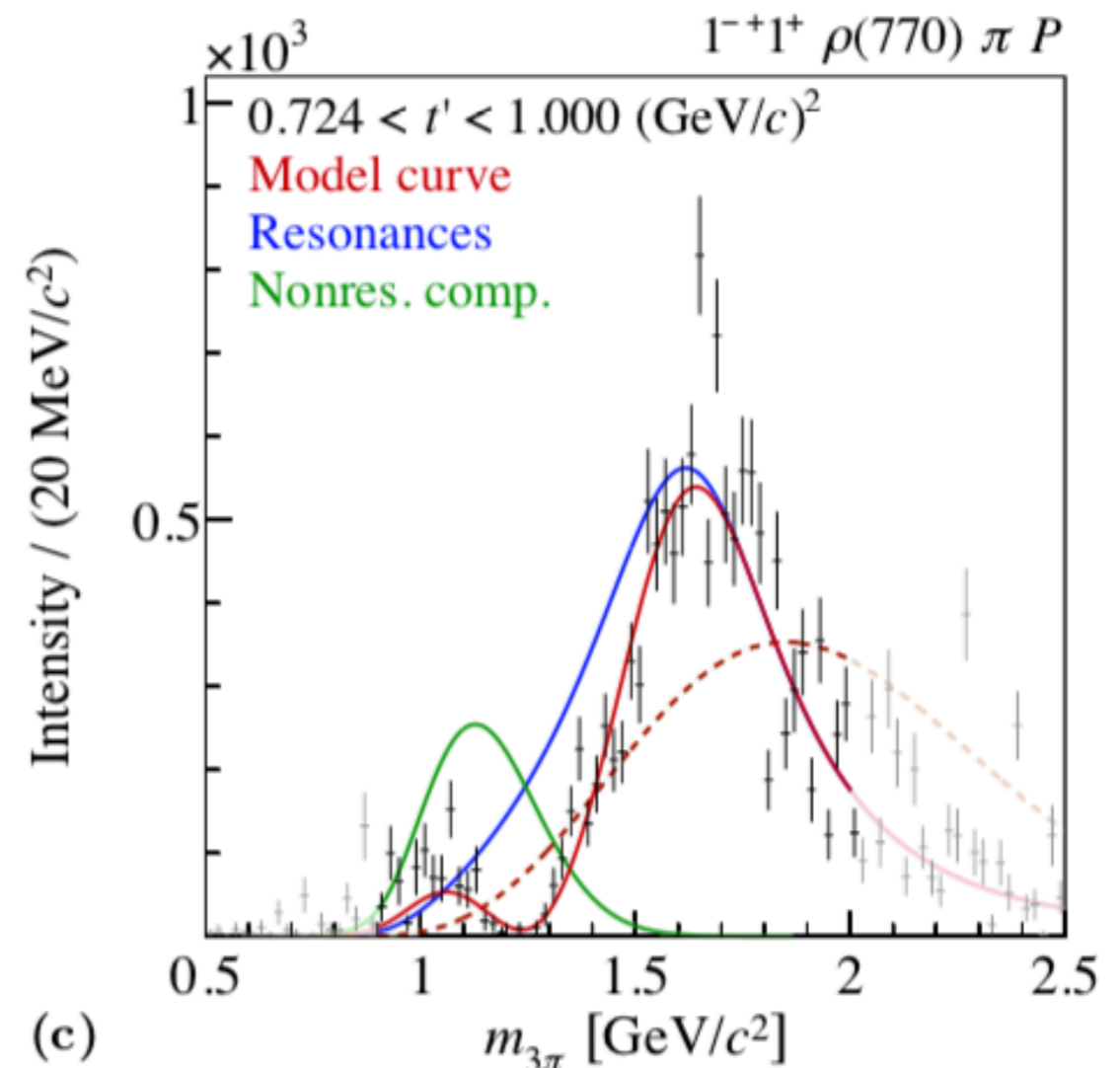
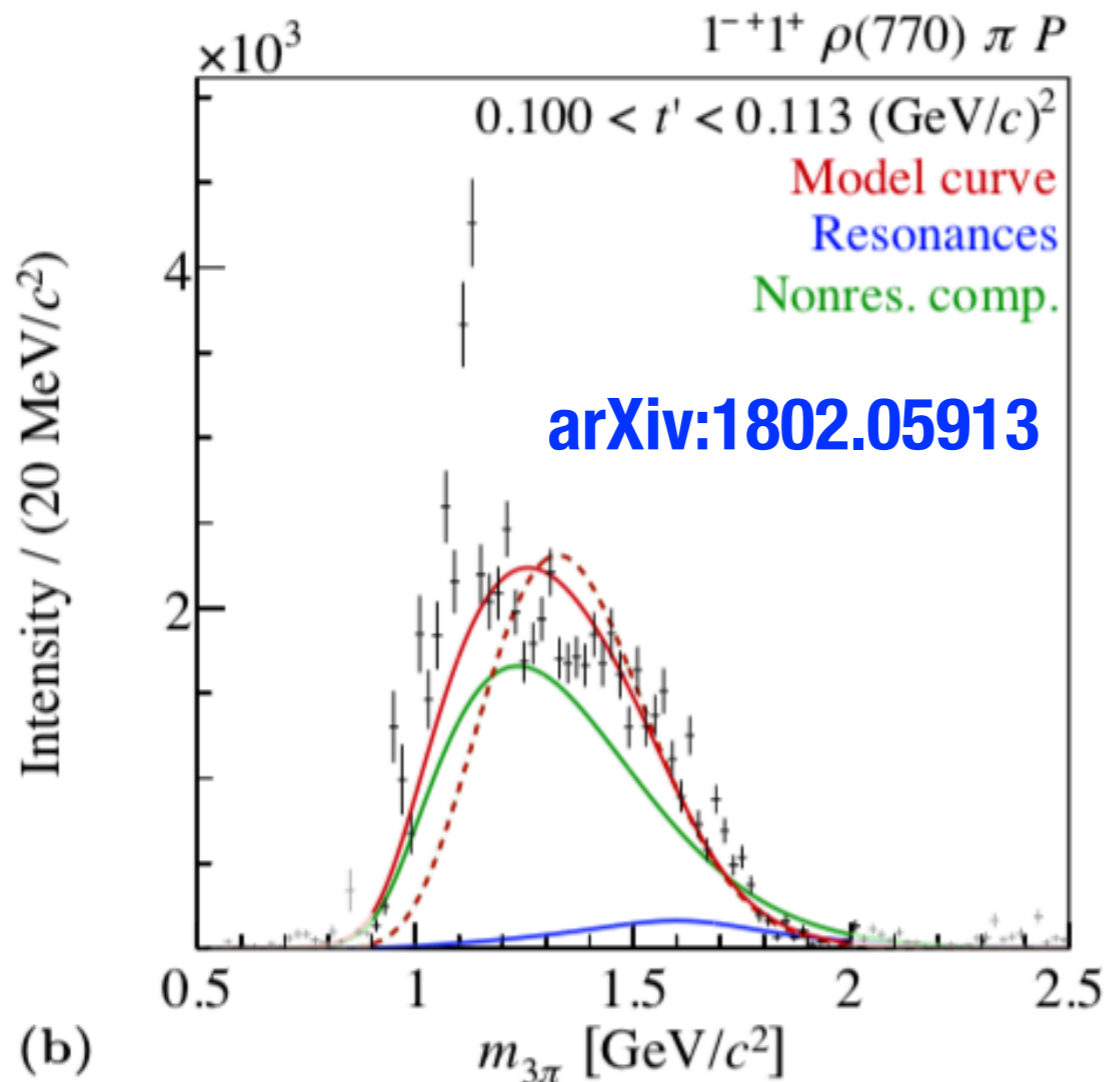

Need to work with theorists on better models for resonant and non-resonant:

Joint Physics Analysis Center *J*PAC

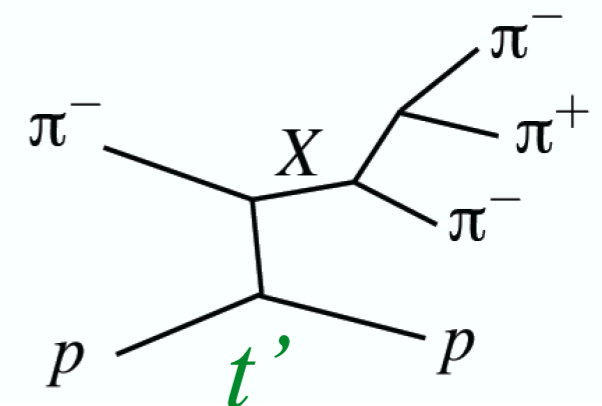

Evidence for hybrids: $\eta^{(\prime)}\pi$ spectroscopy

COMPASS: $\pi^- p \rightarrow \eta^{(\prime)}\pi^- p$

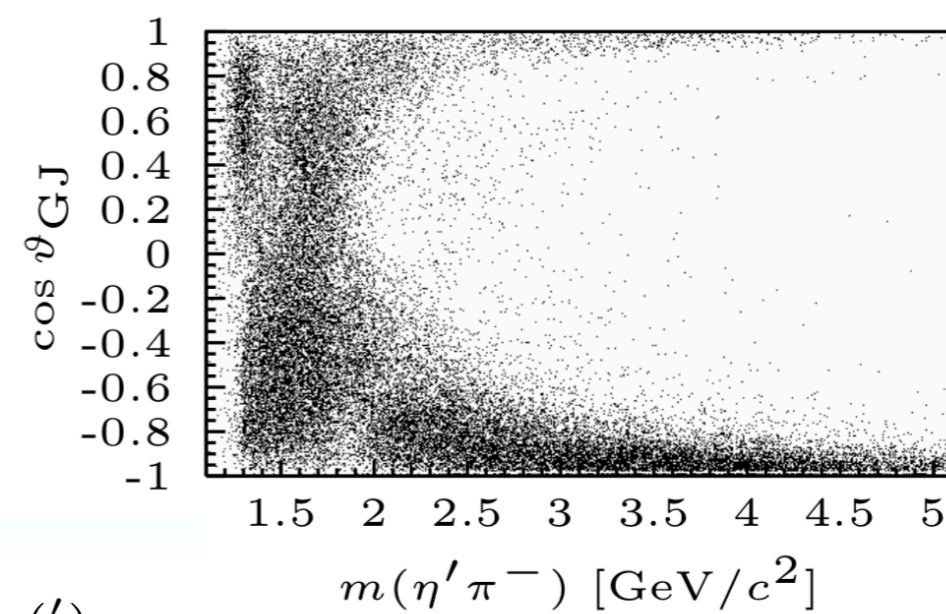
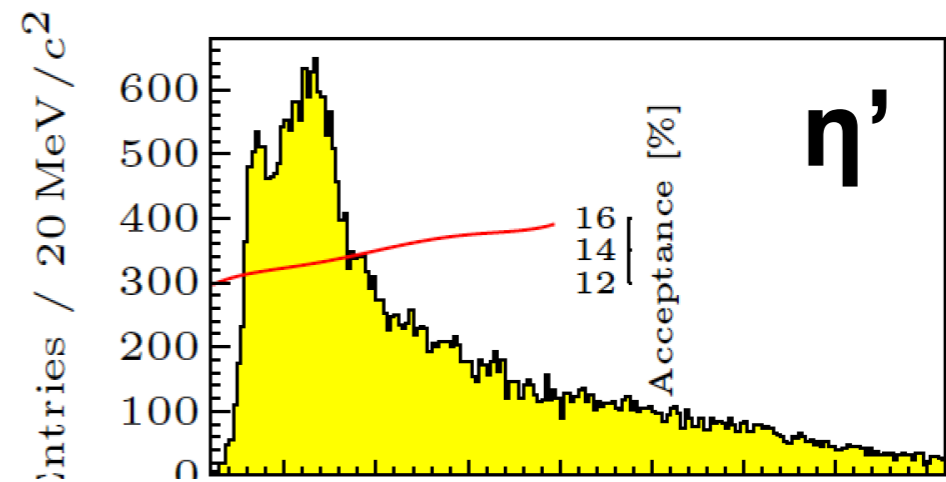
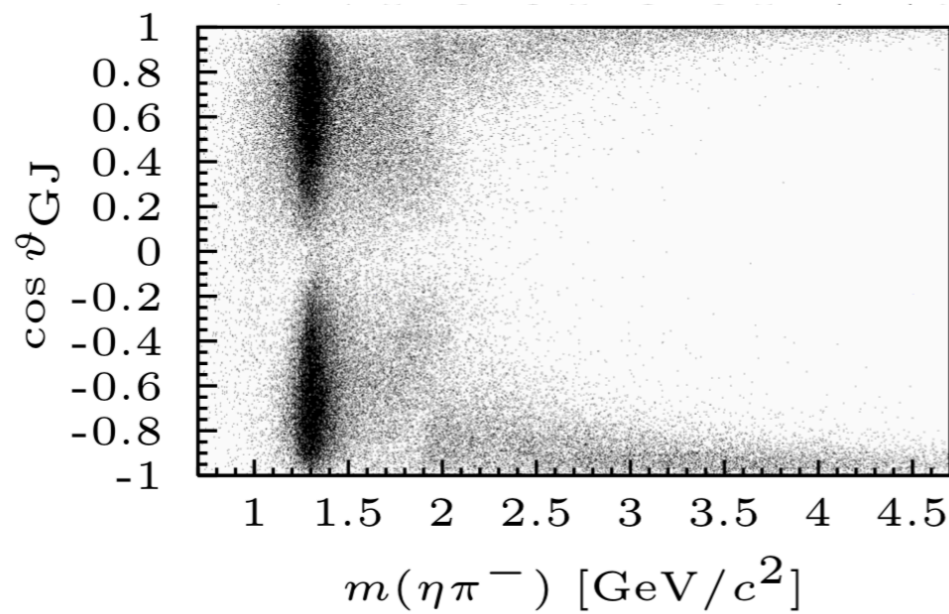
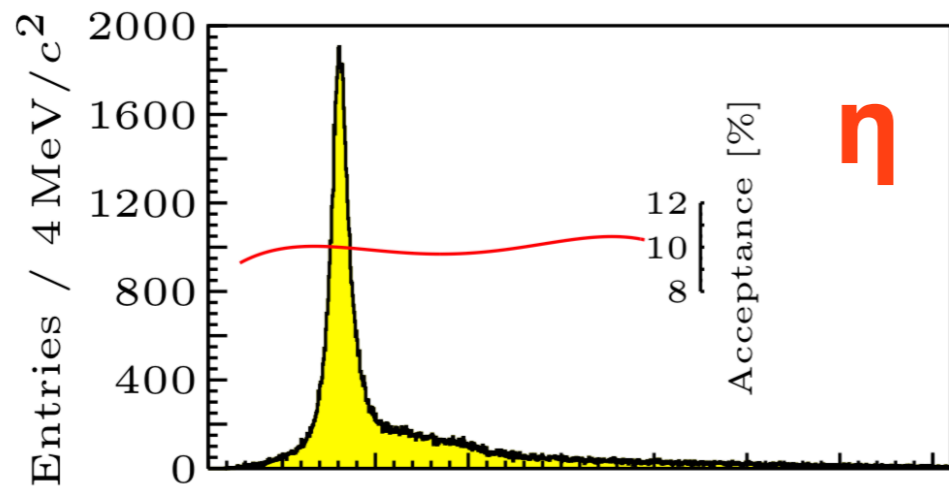

PLB 740 (2015) 303

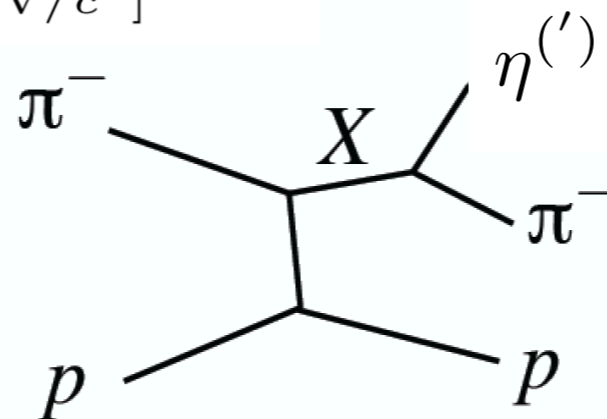

Evidence for hybrids: $\eta^{(\prime)}\pi$ spectroscopy

COMPASS: $\pi^- p \rightarrow \eta^{(\prime)}\pi^- p$

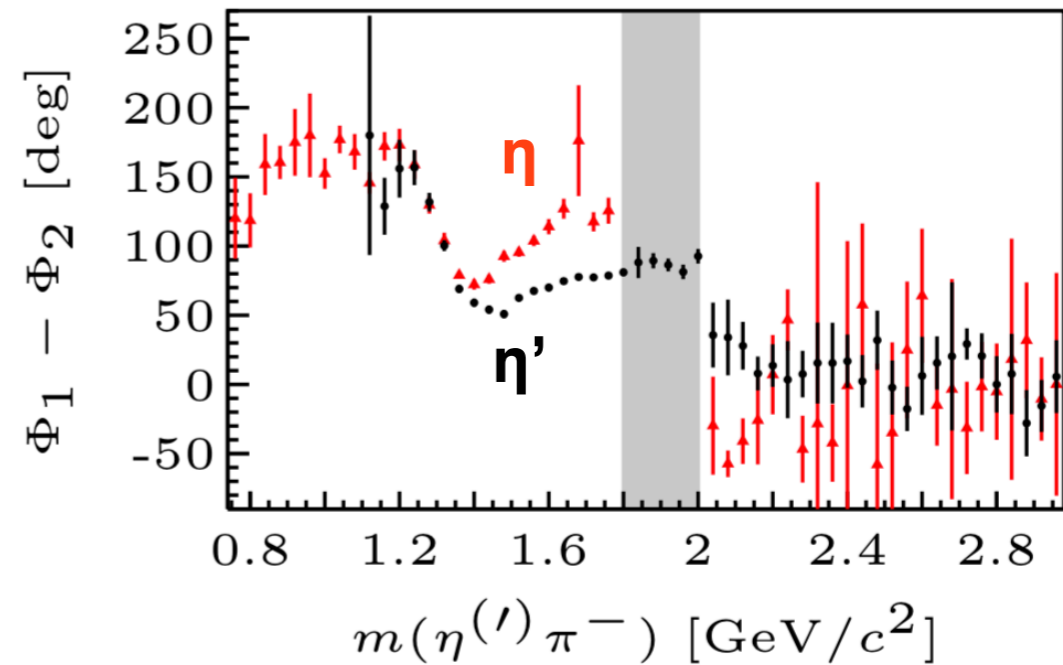
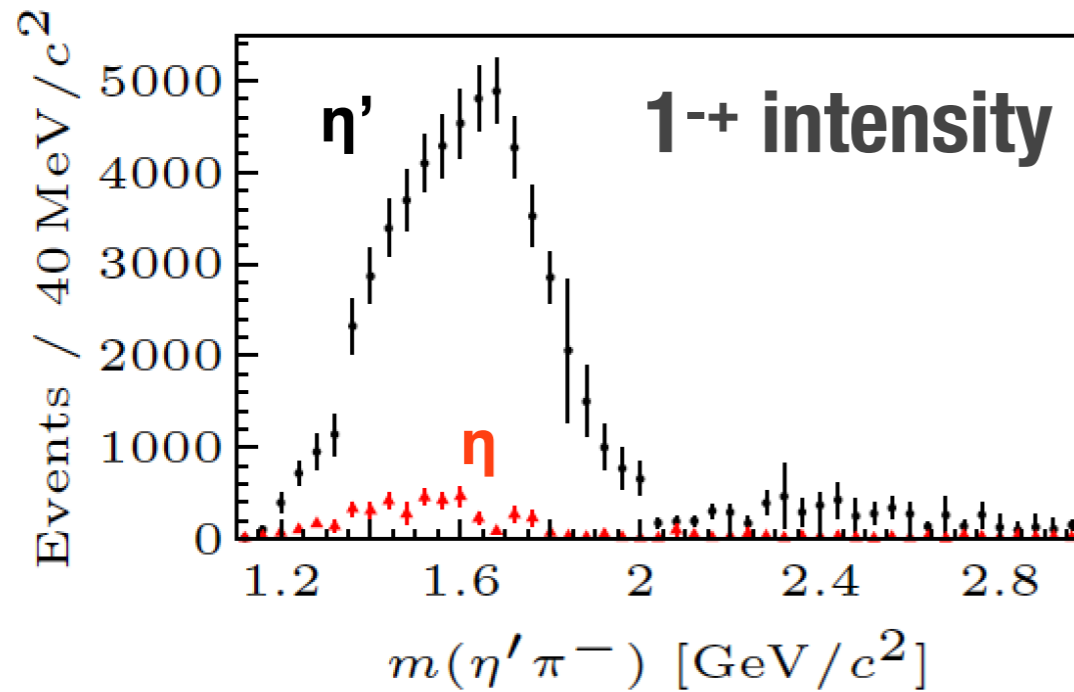

PLB 740 (2015) 303



Need to work with theorists on better models to describe broad structures:

Joint Physics Analysis Center 

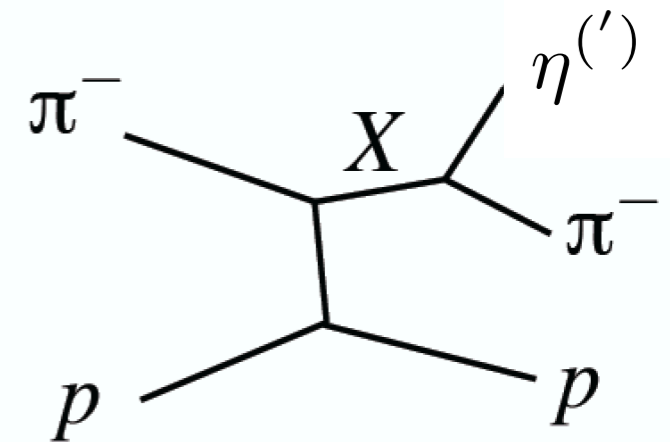

Evidence for hybrids: $\eta^{(\prime)}\pi$ spectroscopy

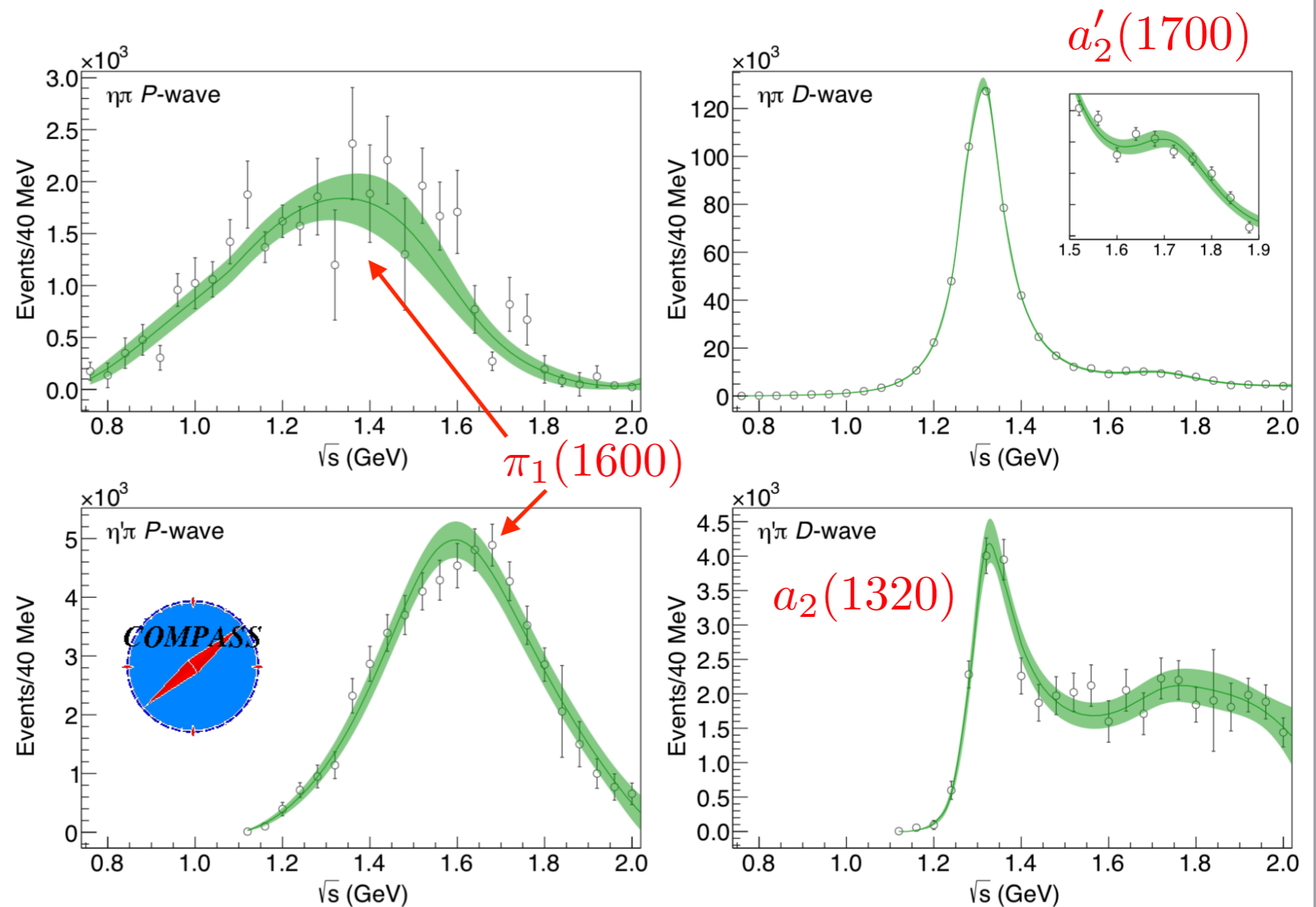
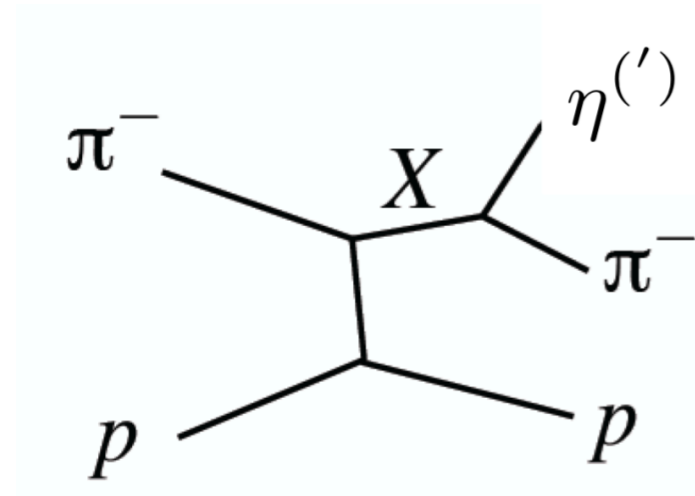

JPAC coupled channel fit to $\eta\pi$ and $\eta'\pi$ determine pole positions for a_2 , a'_2 and single exotic $\pi_1(1600)$

COMPASS: PLB 740 (2015) 303
JPAC: PRL 122 (2019) 042002

Summary

- * Hybrid mesons provide unique access to gluonic degrees of freedom in bound states
- * Lattice QCD predicts a rich spectrum of hybrid mesons, some with exotic J^{PC}
- * Significant evidence for exotic $J^{PC} = 1^{-+}$ in the literature, but interpretation is murky
- * The search for a coherent pattern of gluonic excitations continues...

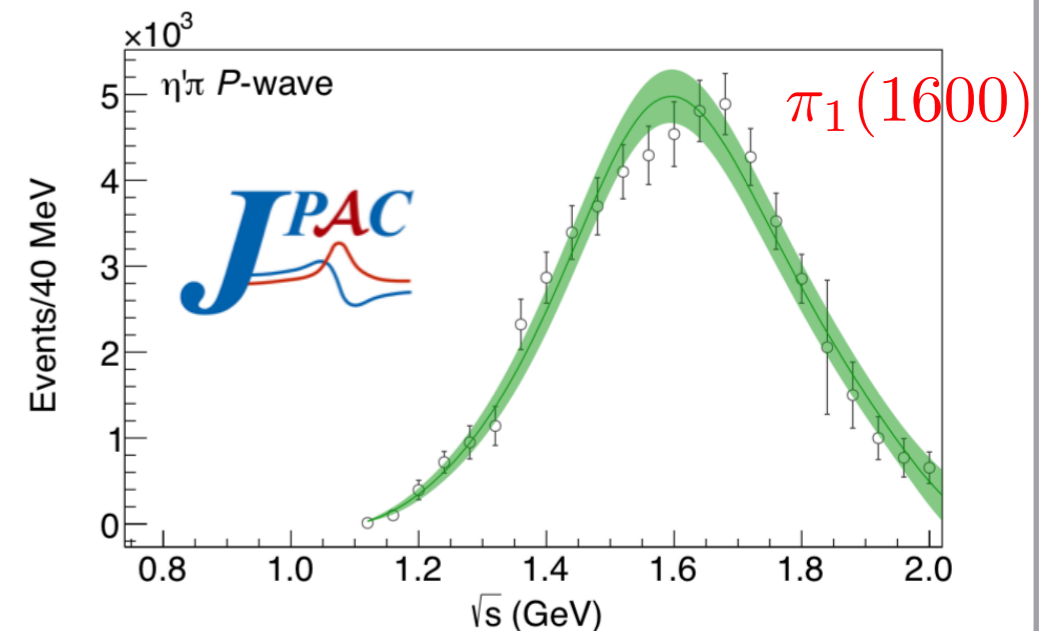
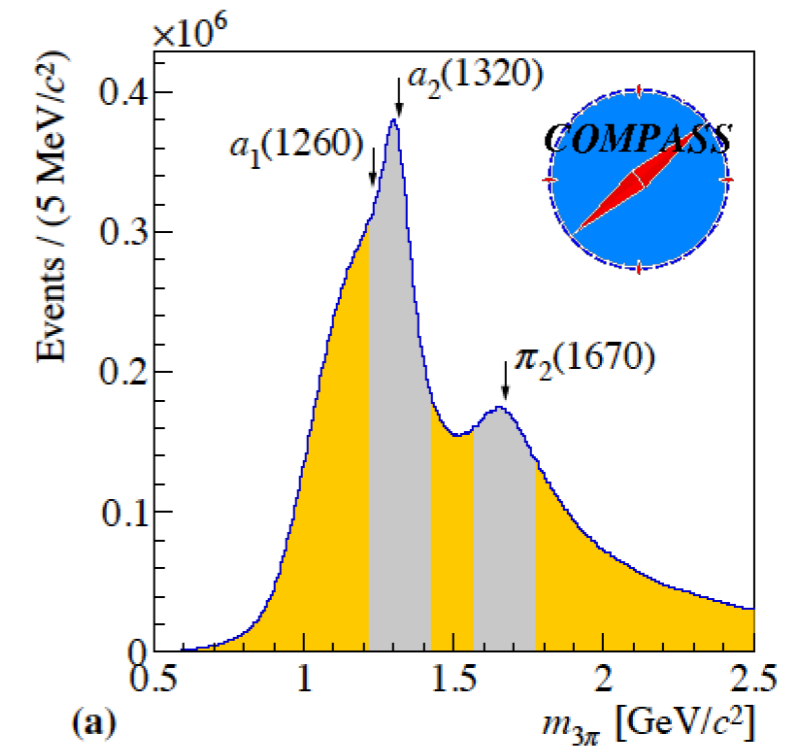
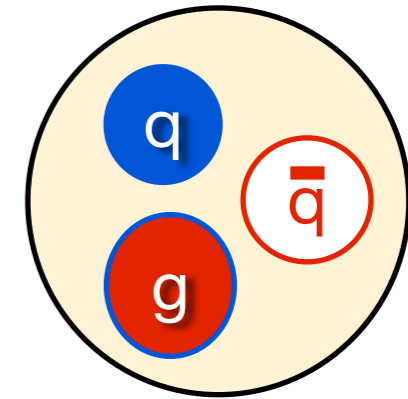

Hadron Spectroscopy at GlueX and Beyond (4)

Justin Stevens



WILLIAM & MARY

CHARTERED 1693

Jefferson Lab

- * JLab 12 GeV running since 2017: programs in hadron spectroscopy, nucleon and nuclear structure, etc.
- * Photoproduction process provides access to many proposed exotic decay channels
- * Orders of magnitude higher statistics than previous photoproduction experiments

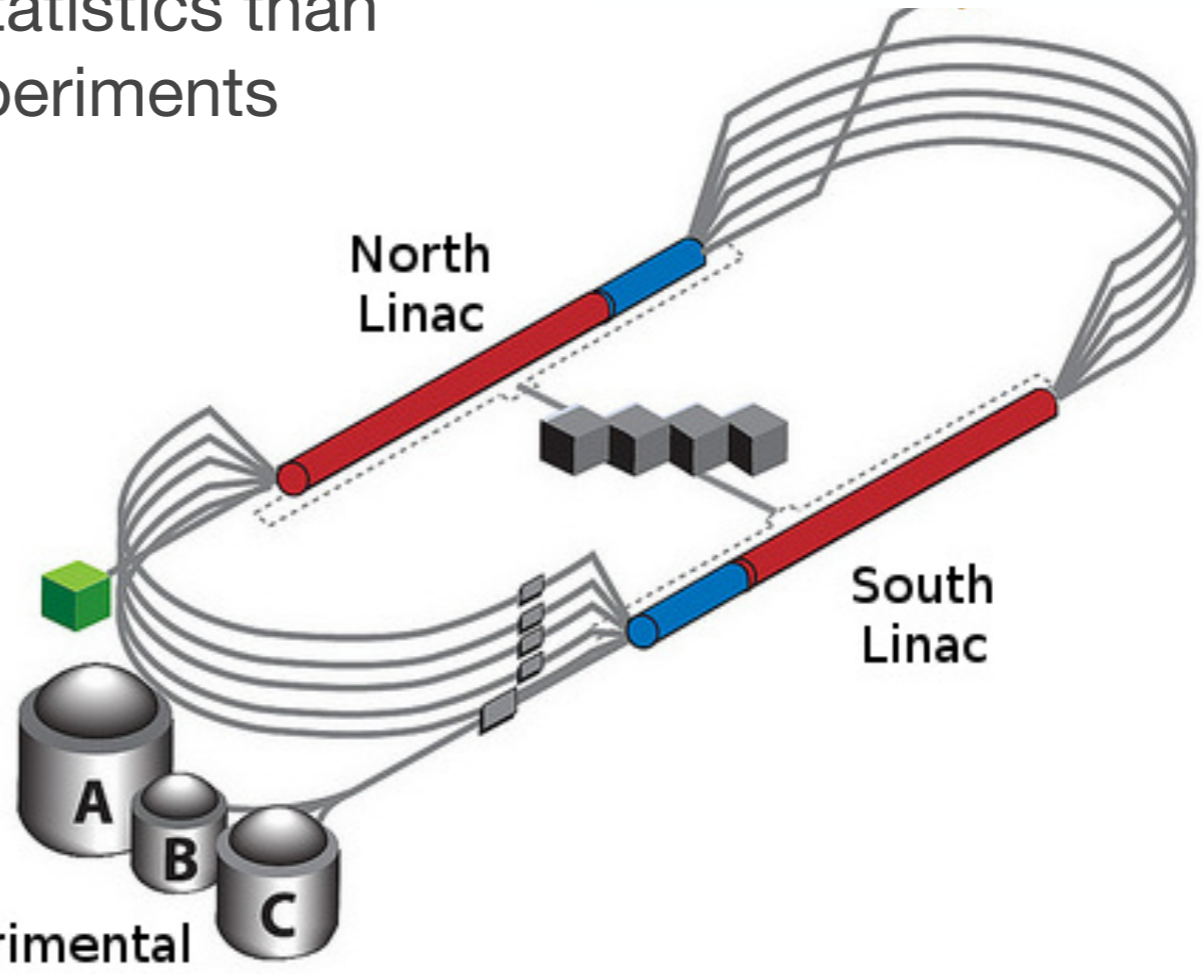
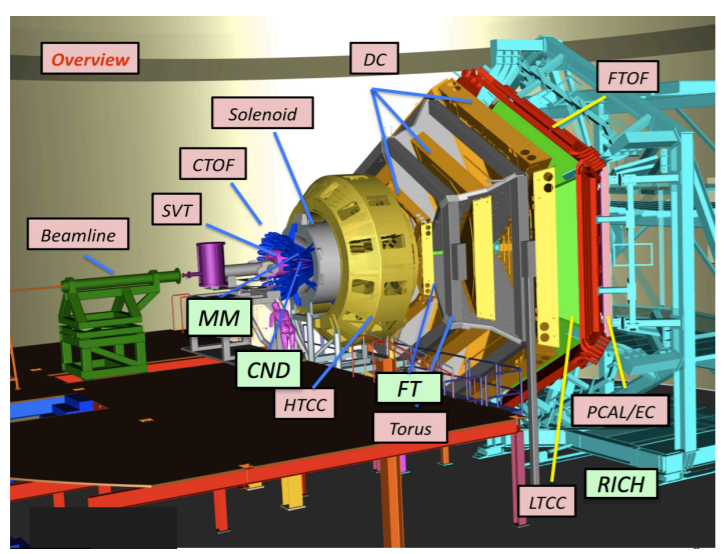
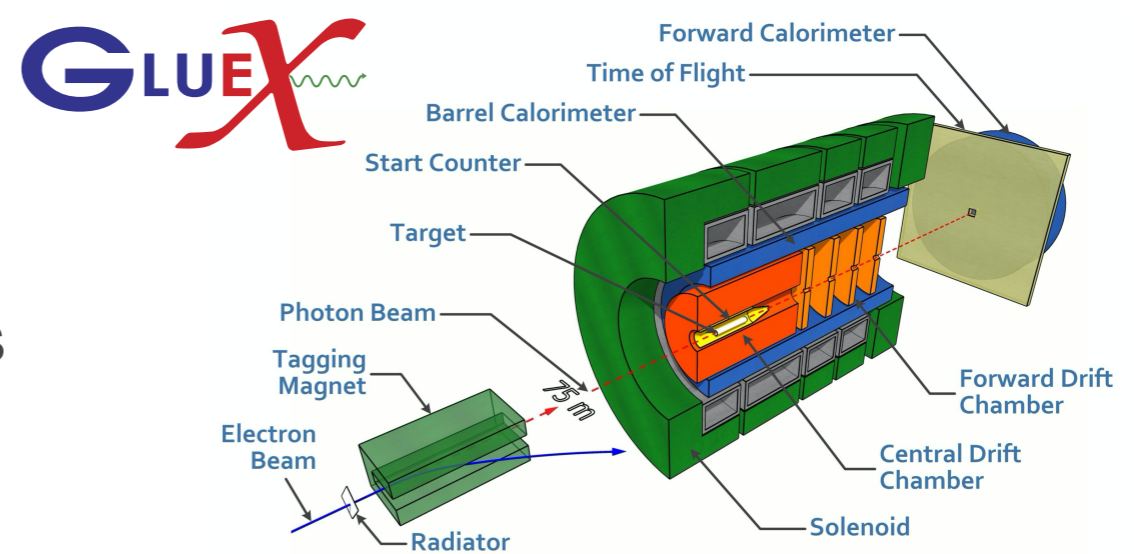

GLUEX in Hall D

- * Linearly polarized photon beam from CEBAF 12 GeV
- * Large acceptance detector for both charged and neutral particles

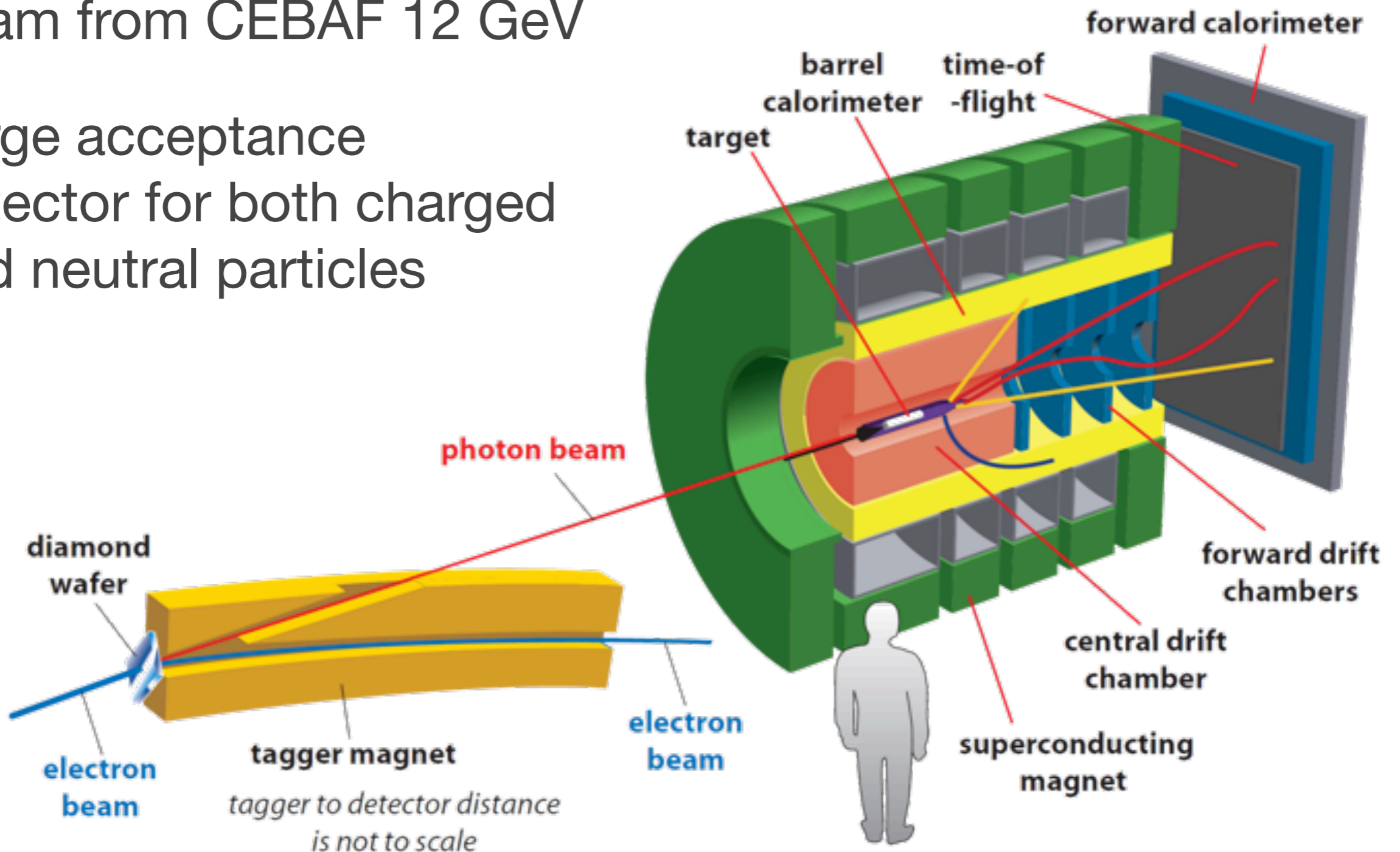

Photon Beam and Tagger

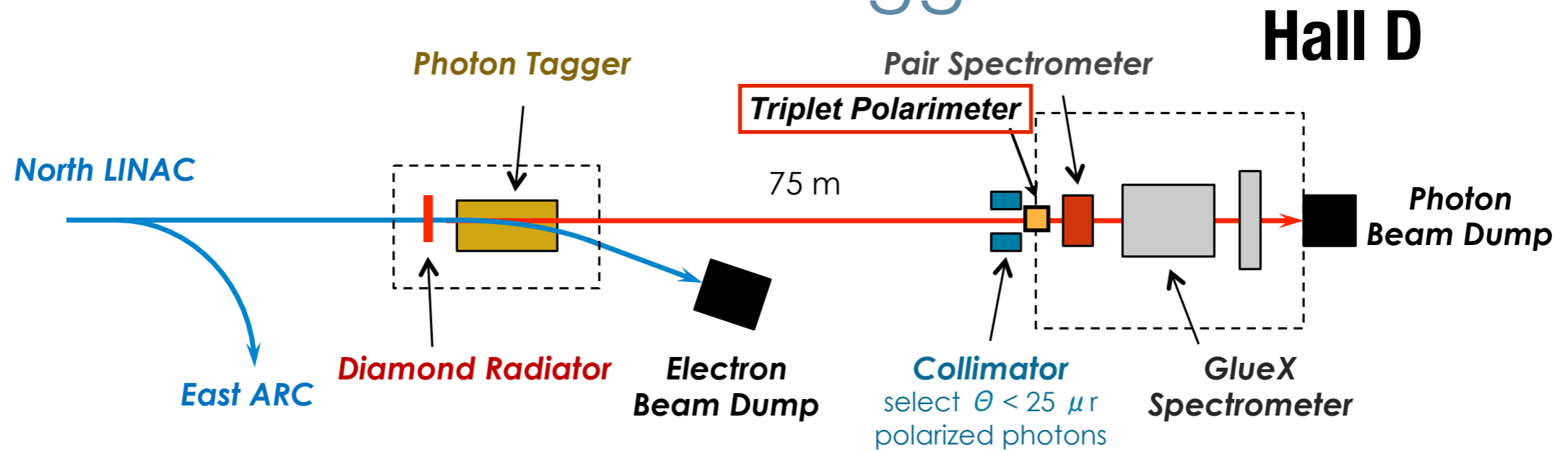

Measured Flux

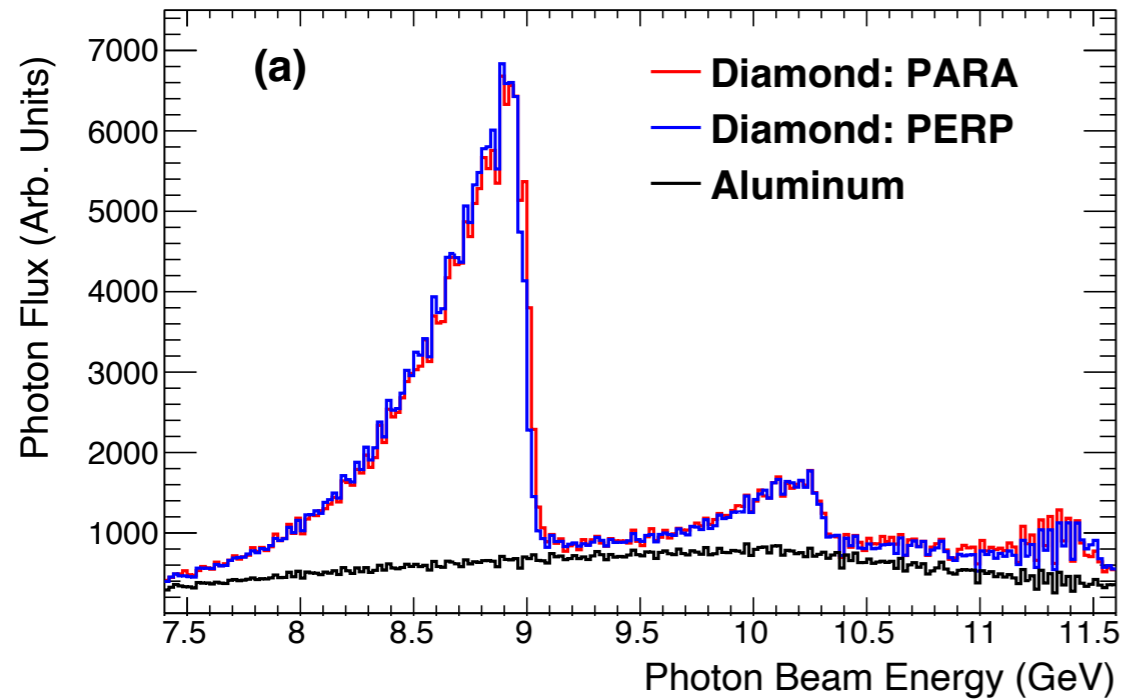

Measured Polarization

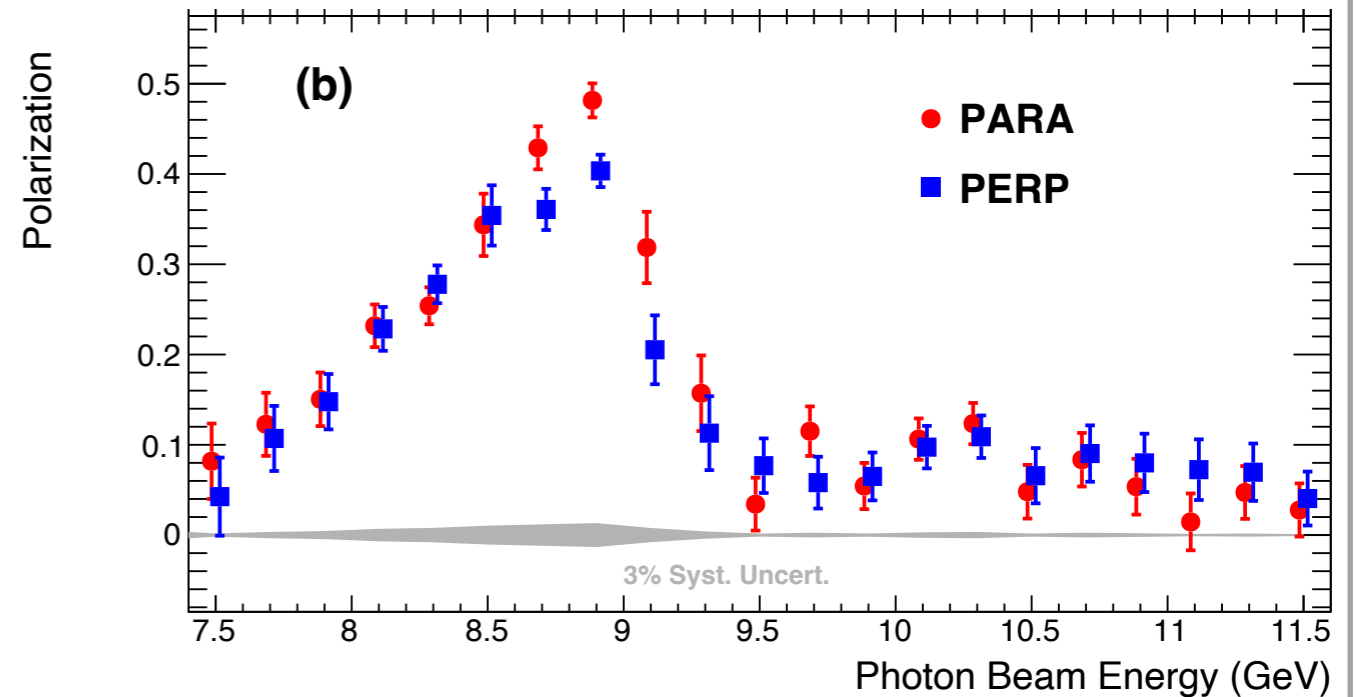



Construction (~5 years)



“Typical” $\gamma p \rightarrow \pi^+ \pi^- p$ event

top view (looking down from above detector)

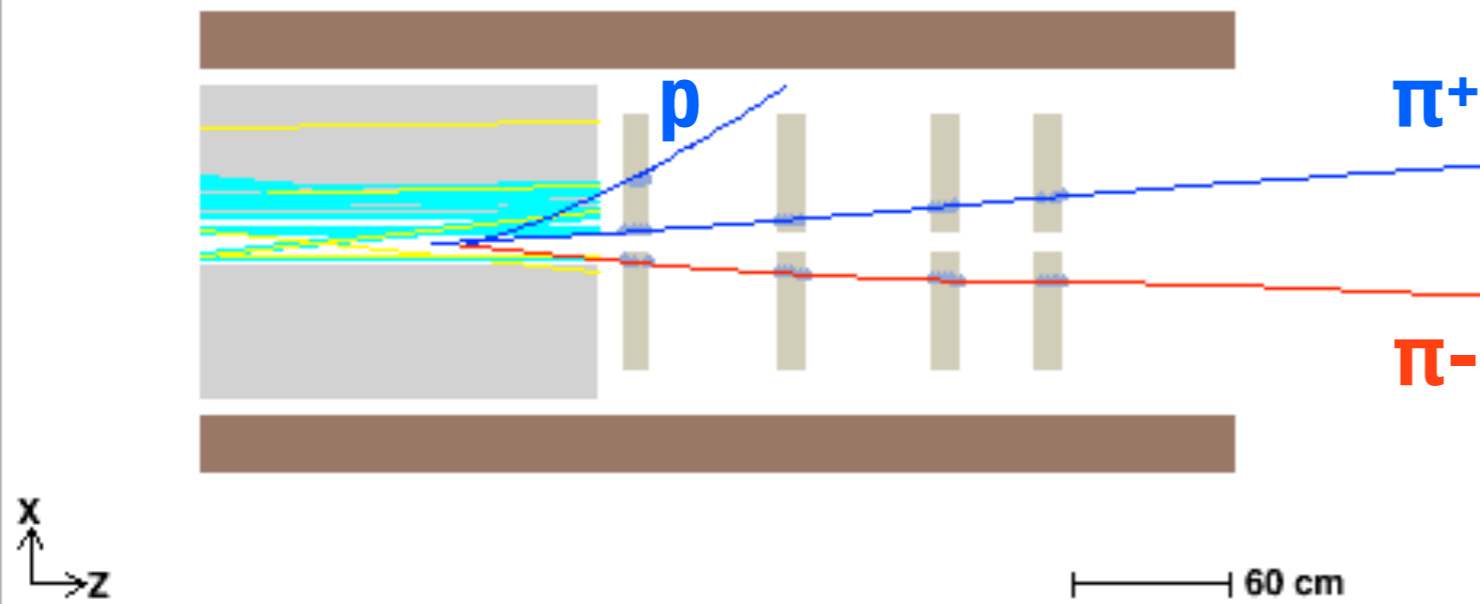

side view from beam right (south)

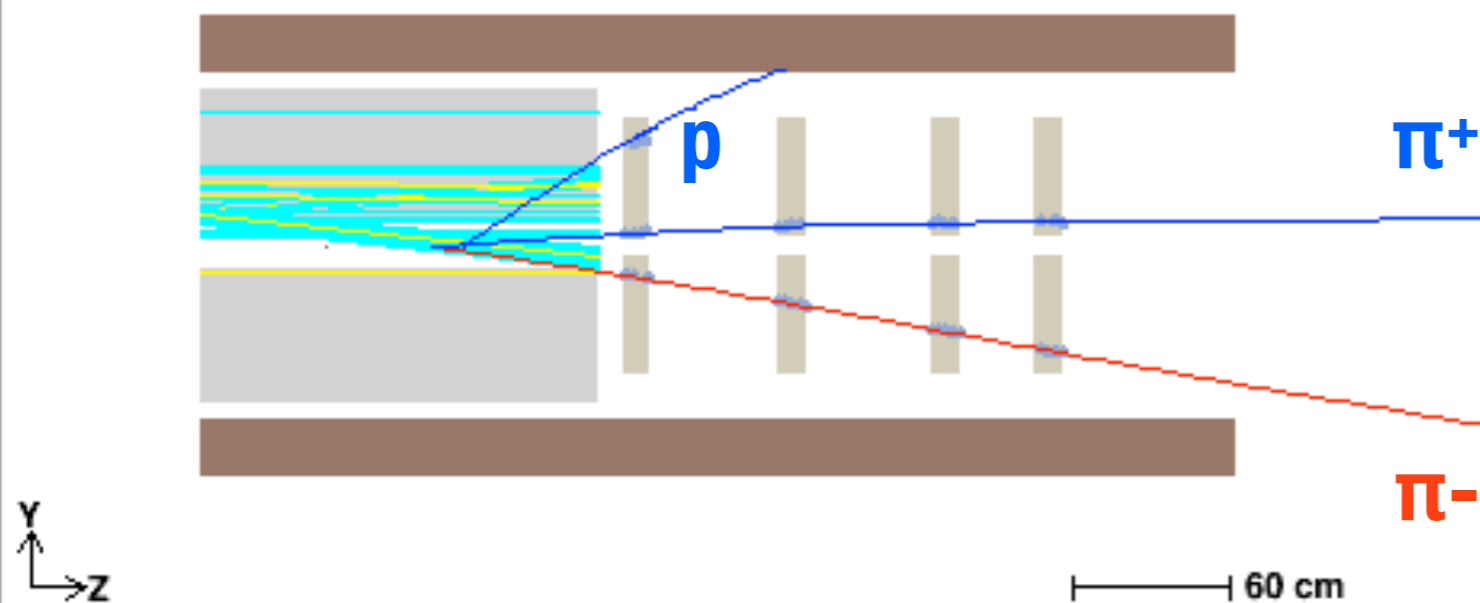

BCAL view from downstream looking upstream

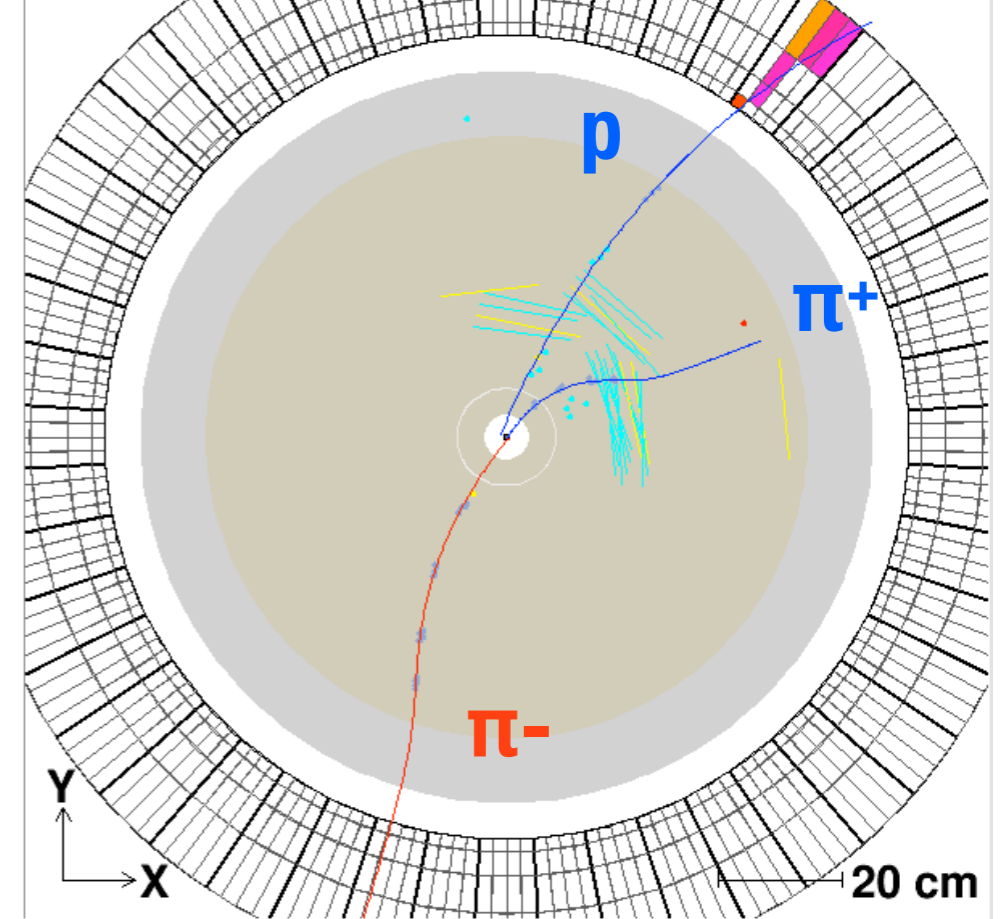

Exotic J^{PC} in photoproduction

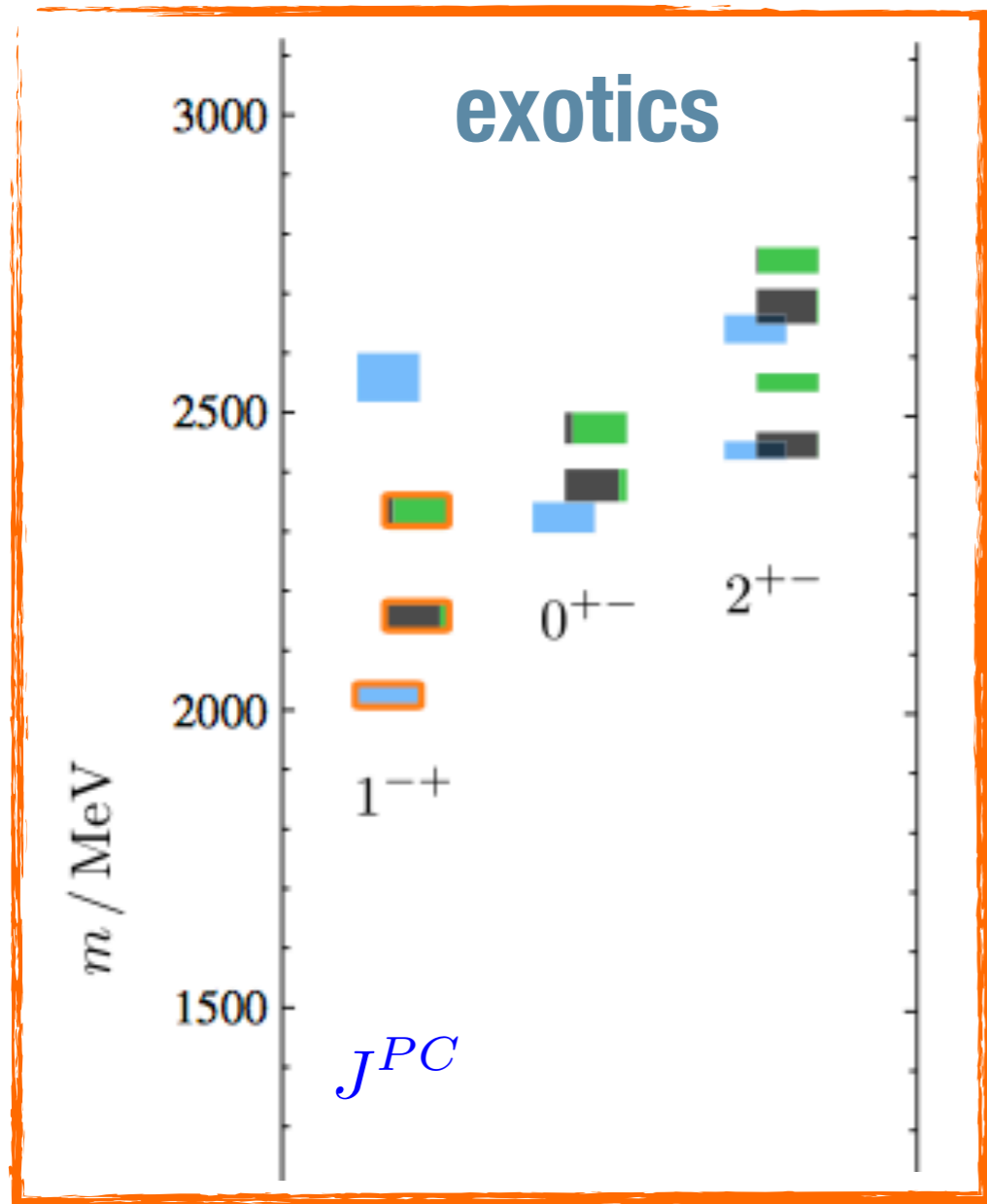

Meson X with particular J^{PC}

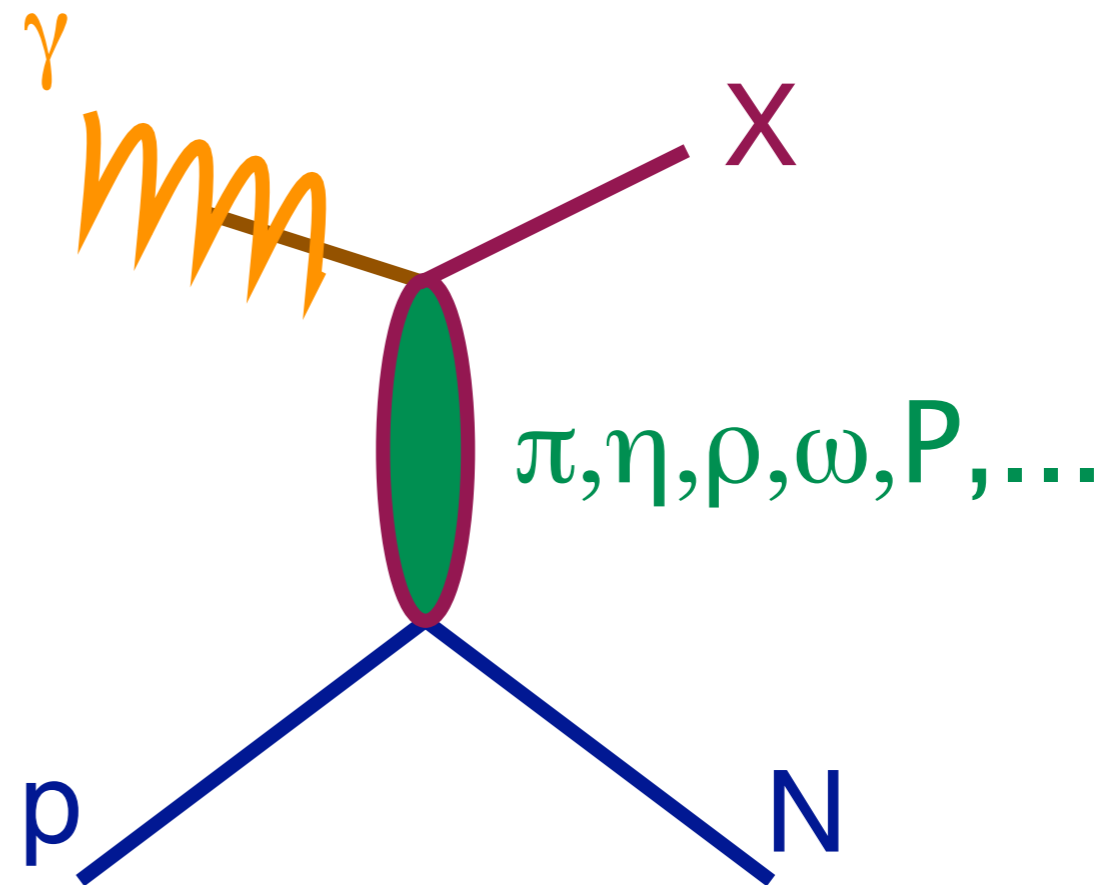

**Production through t-channel
“quasi-particle” exchange**

$\eta\pi$ spectroscopy at



- * Broad overlapping resonances requires amplitude, described by decay angles θ , ϕ

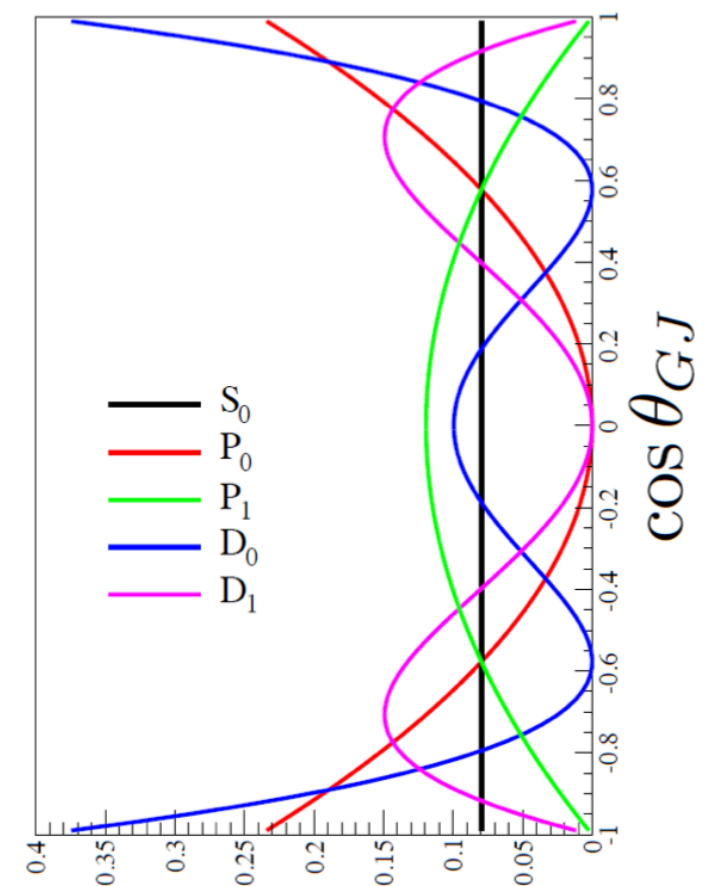
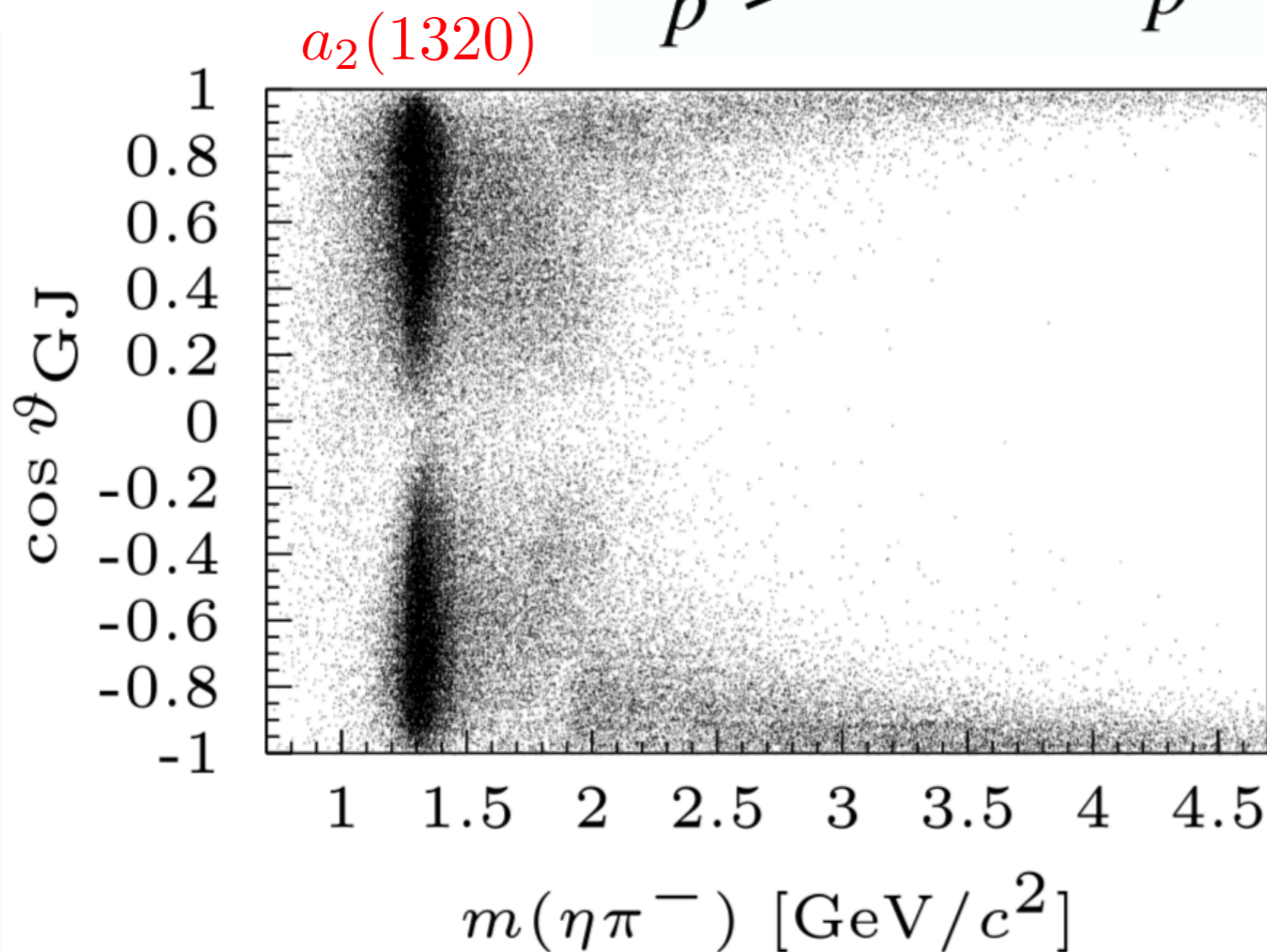
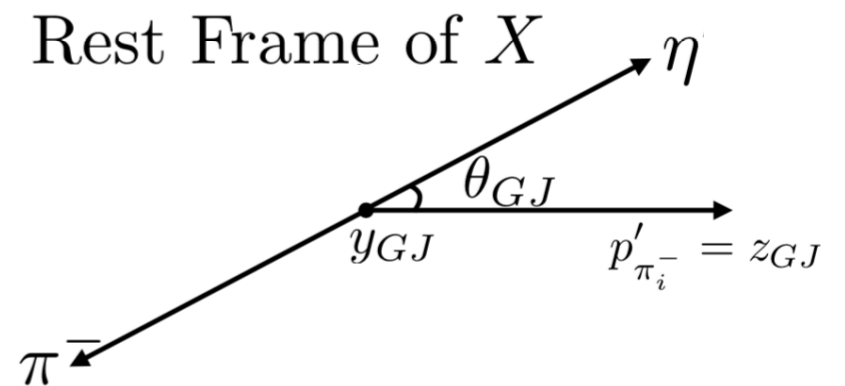
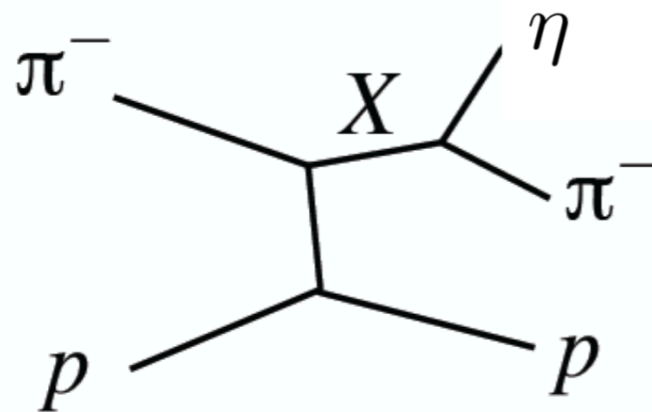

$\eta\pi$ spectroscopy at



- * Broad overlapping resonances requires amplitude, described by decay angles θ , ϕ
- * Polarized photon beam provides new information on production mechanism, collaborating with **JPAC** on amplitudes

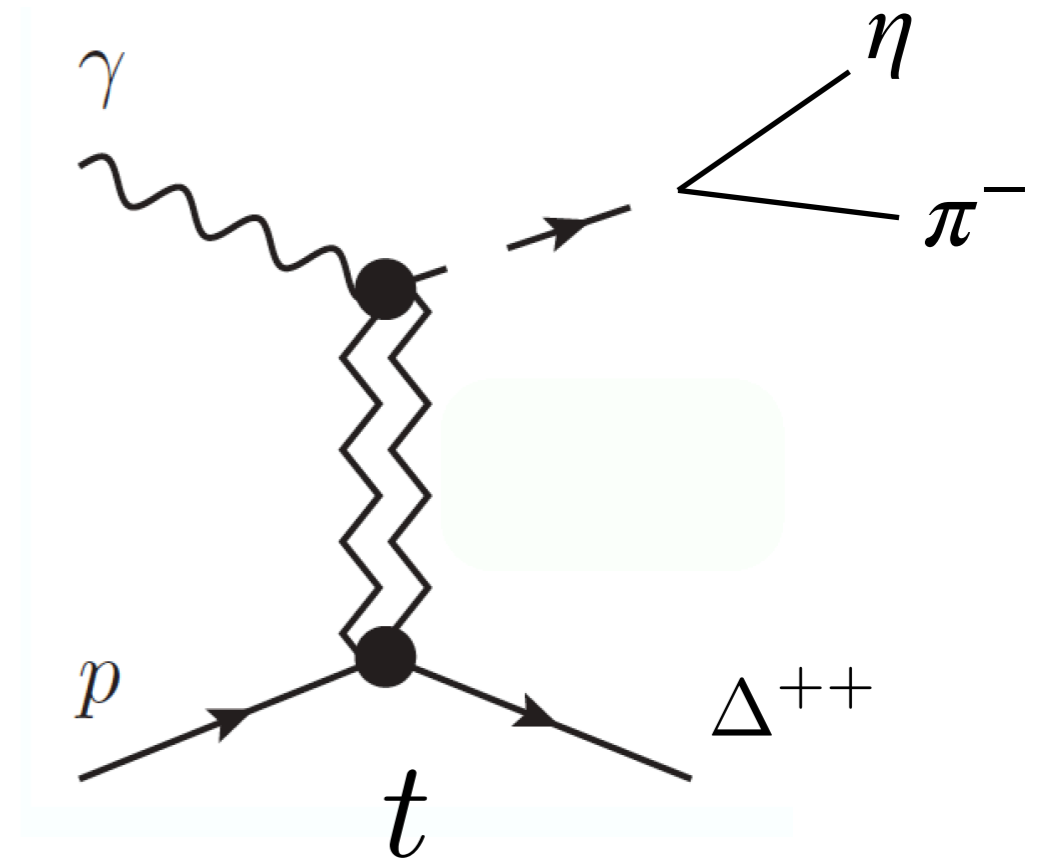
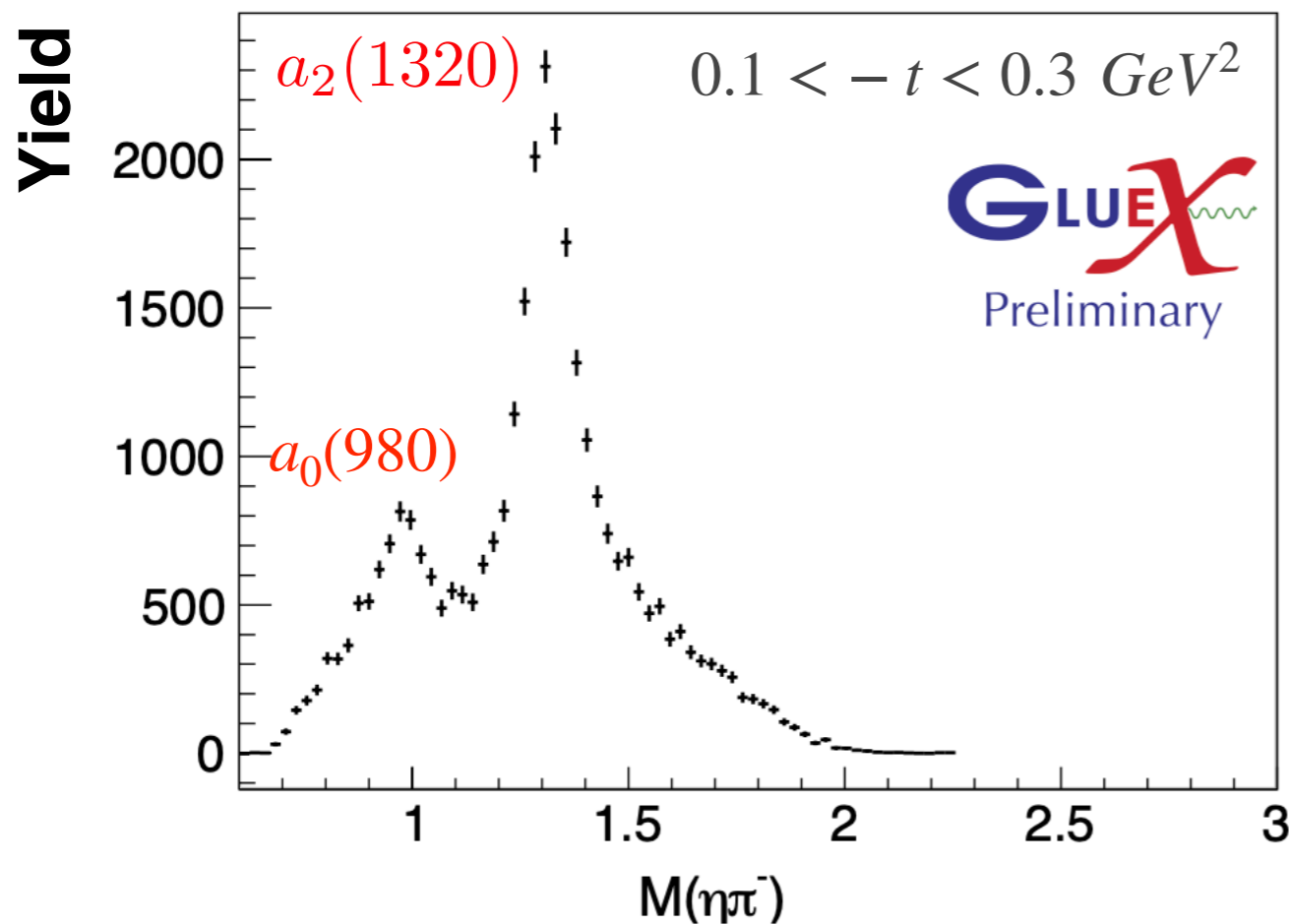
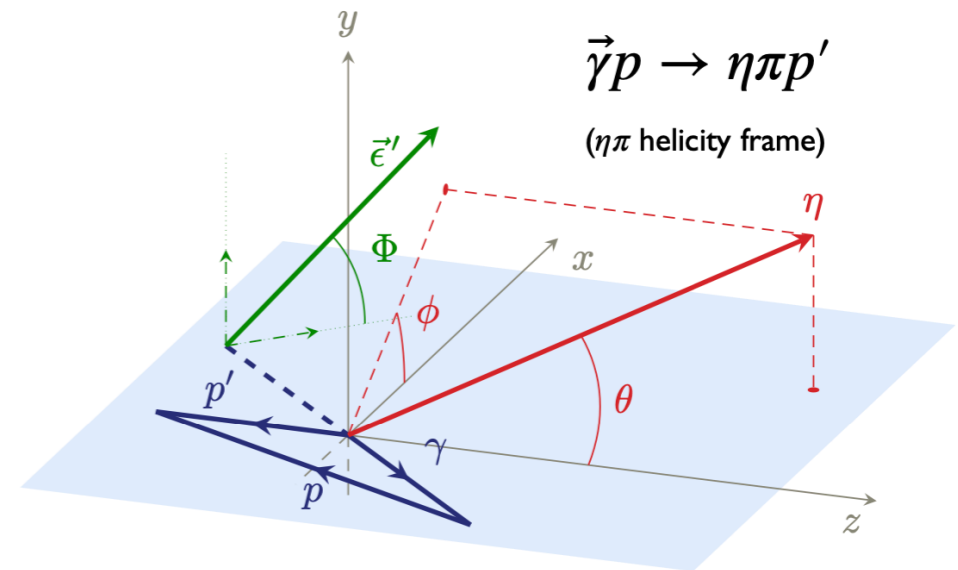

$\eta\pi$ spectroscopy at **GLUEX**

- * Broad overlapping resonances requires amplitude, described by decay angles θ, ϕ
- * Polarized photon beam provides new information on production mechanism, collaborating with **JPARC** on amplitudes

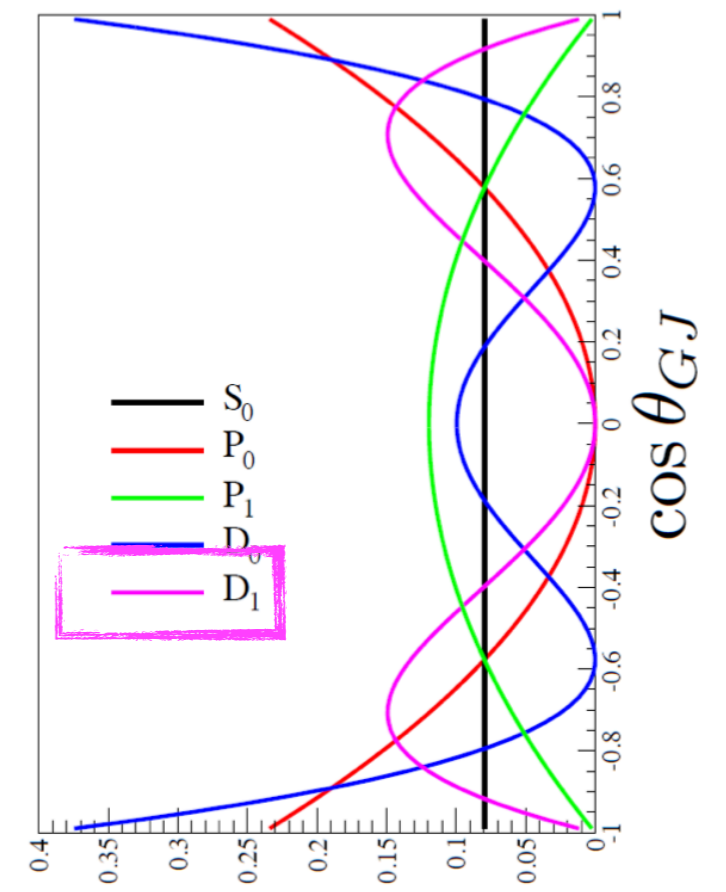
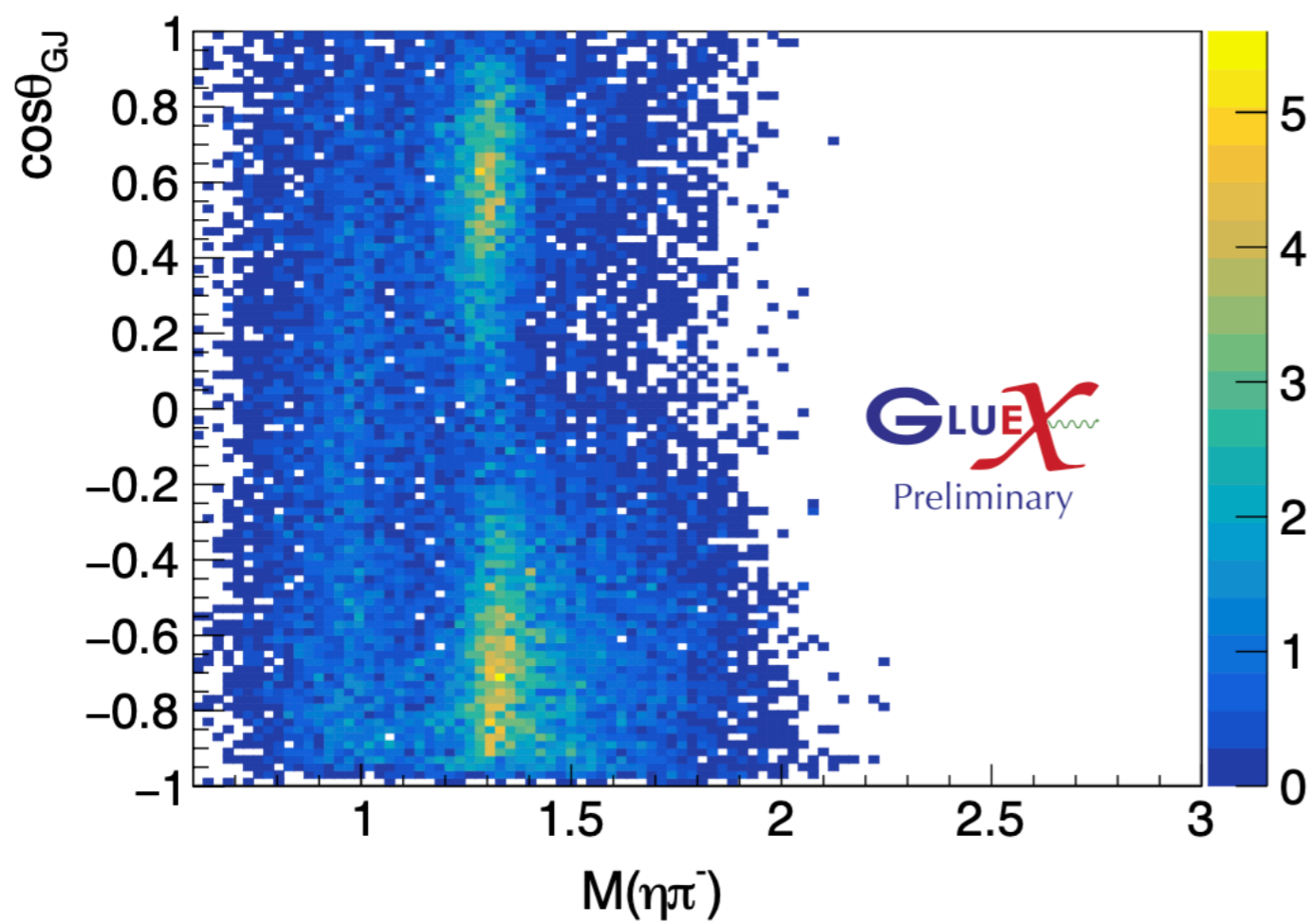
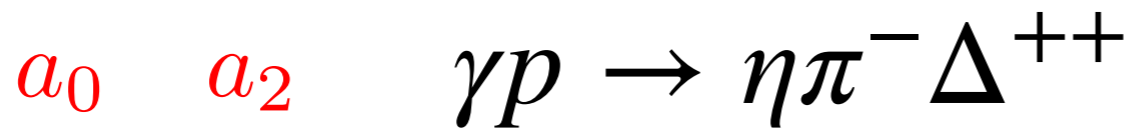
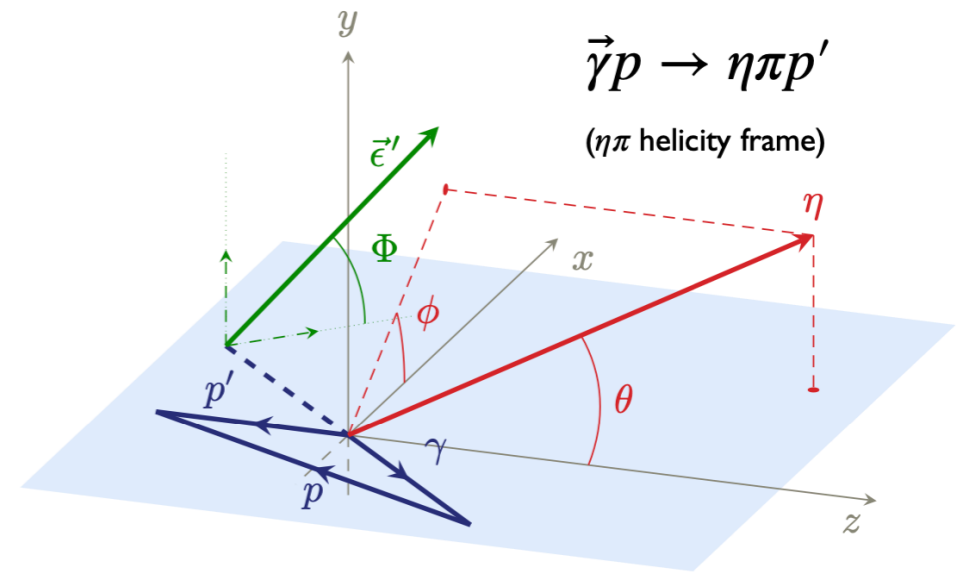

$\eta\pi$ spectroscopy at **GLUEX**

- * Broad overlapping resonances requires amplitude, described by decay angles θ, ϕ
- * Polarized photon beam provides new information on production mechanism, collaborating with **JPARC** on amplitudes

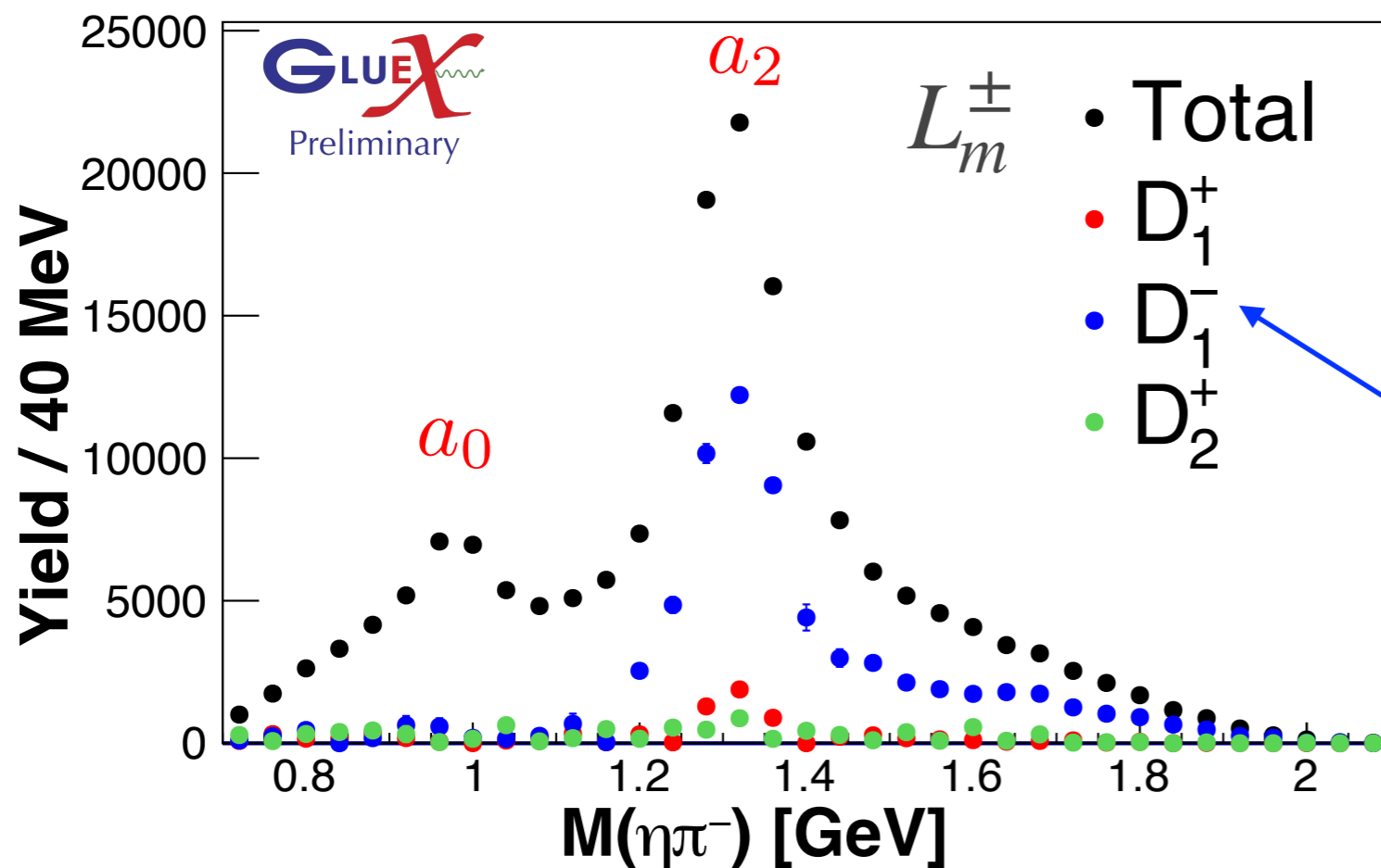
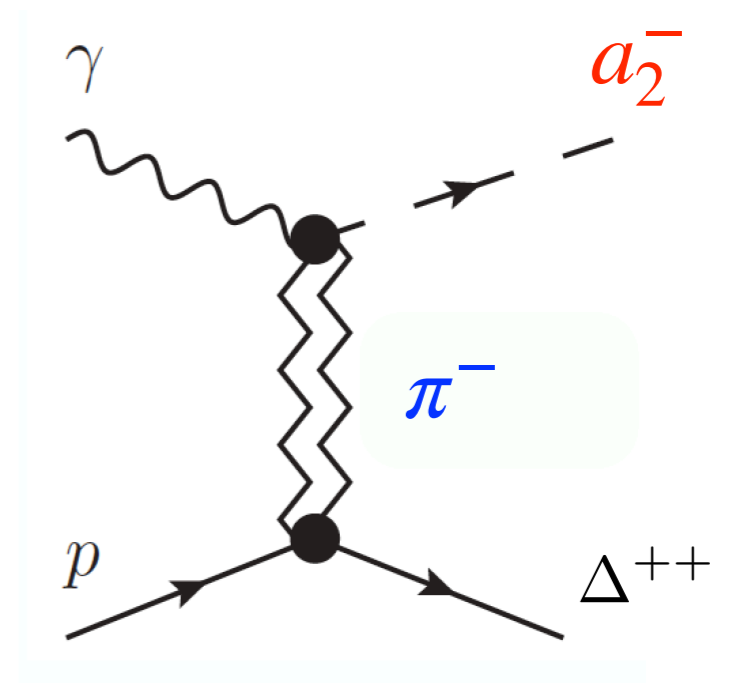

- * Understanding production mechanism for conventional mesons, e.g. a_2^- through unnatural π exchange

Prospects for $\pi_1 \rightarrow \eta' \pi$ with **GLUEX**

$M_{\eta'\pi} = 1600 \text{ MeV}$ COMPASS: PLB 740 (2015) 303

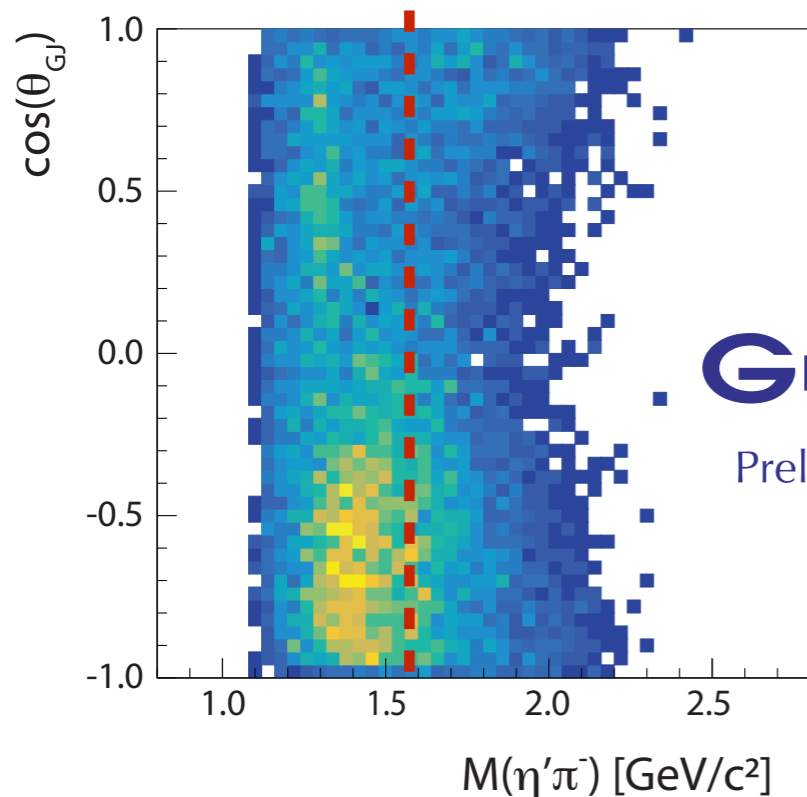
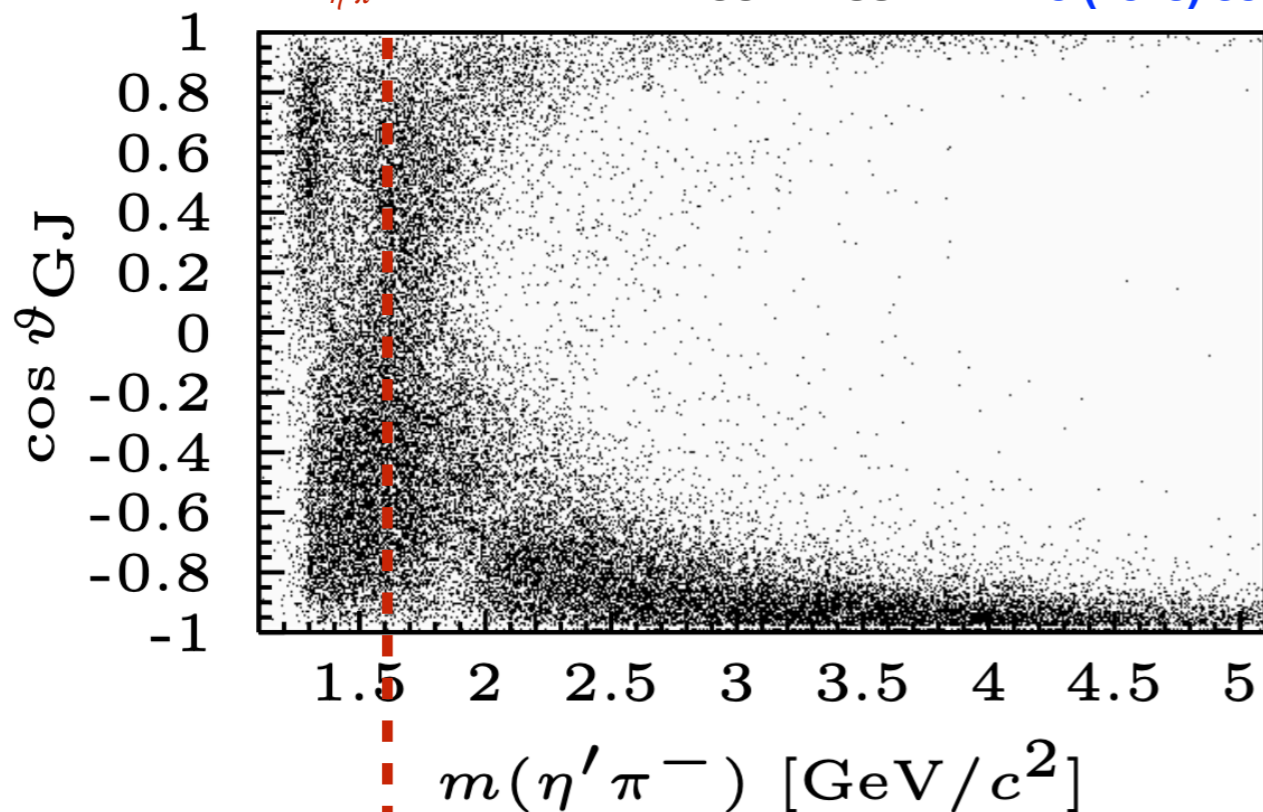

- * Promising $\eta' \pi^-$ channel with similar forward/backward asymmetry to COMPASS
- * Potential for interference between odd (π_1 P-wave) and even (a_2 D-wave) partial waves

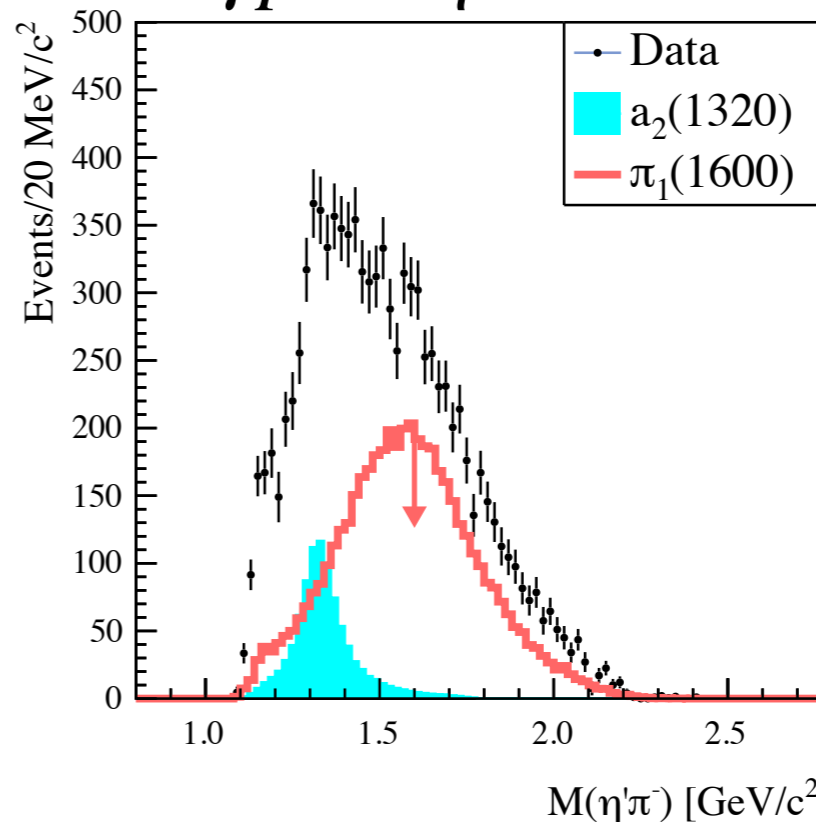
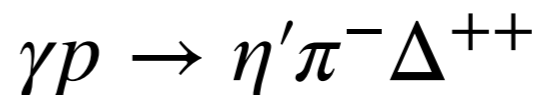

π_1 could be significant relative to a_2

arXiv:2407.03316
Submitted to PRL

Exercise #3: amplitude interference

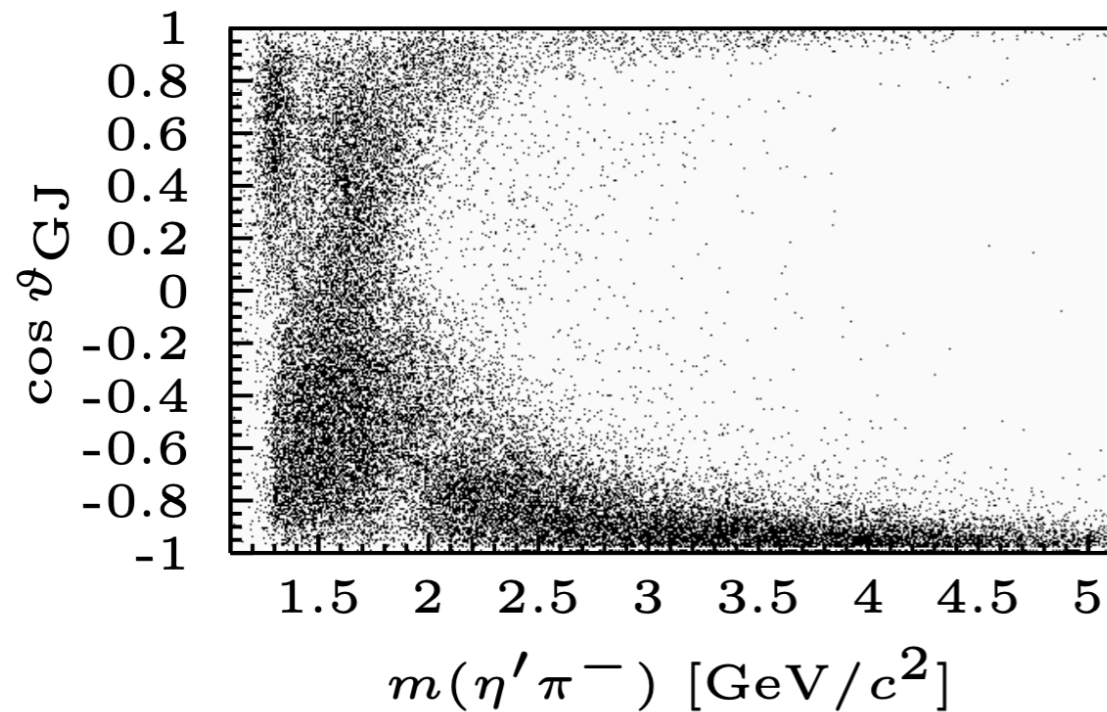

- * Play with parameters of S, P, D waves and observe effect on predicted intensities

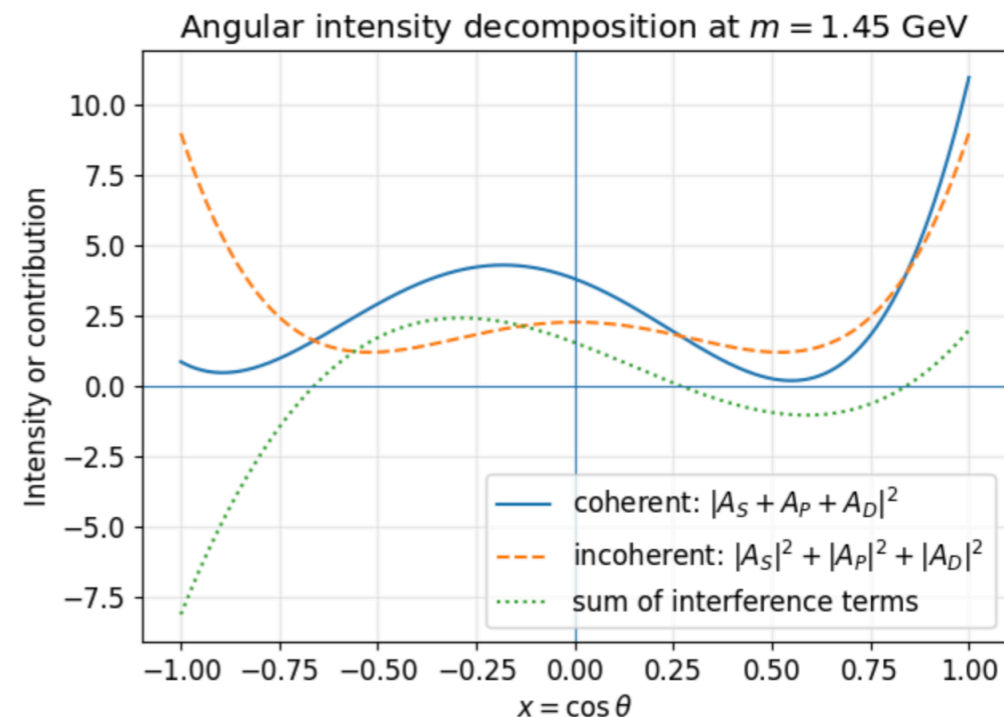
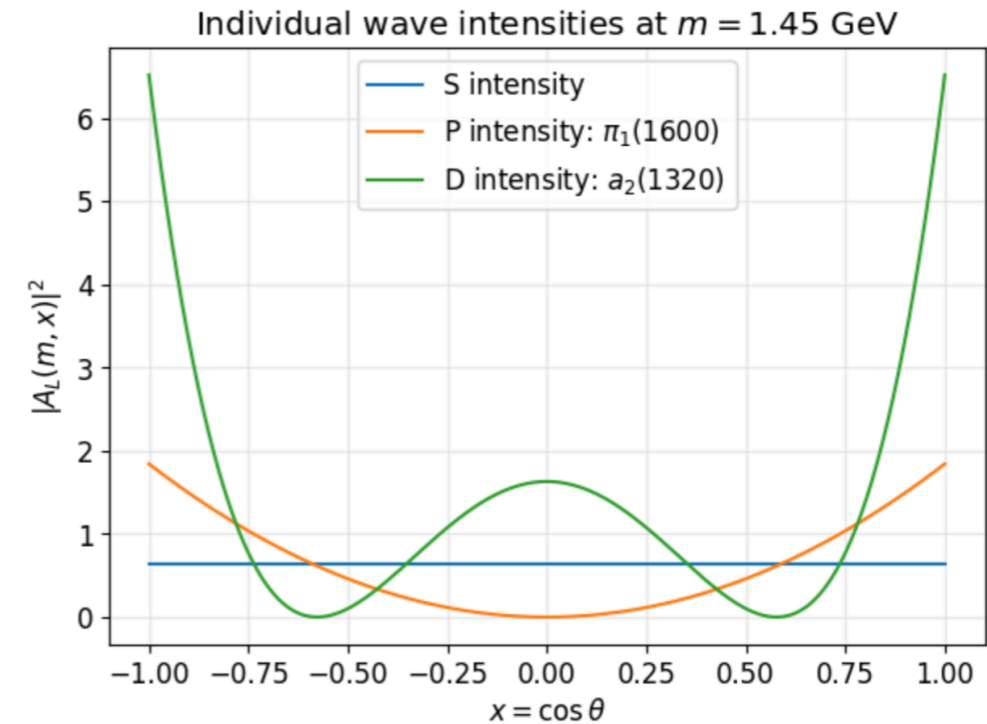

<https://drive.google.com/file/d/18pVtJdHmjbs3756HBjXq7zYM-rVXCGNh/view?usp=sharing>

Another example: $\pi^+\pi^+\pi^-$ at CLAS12

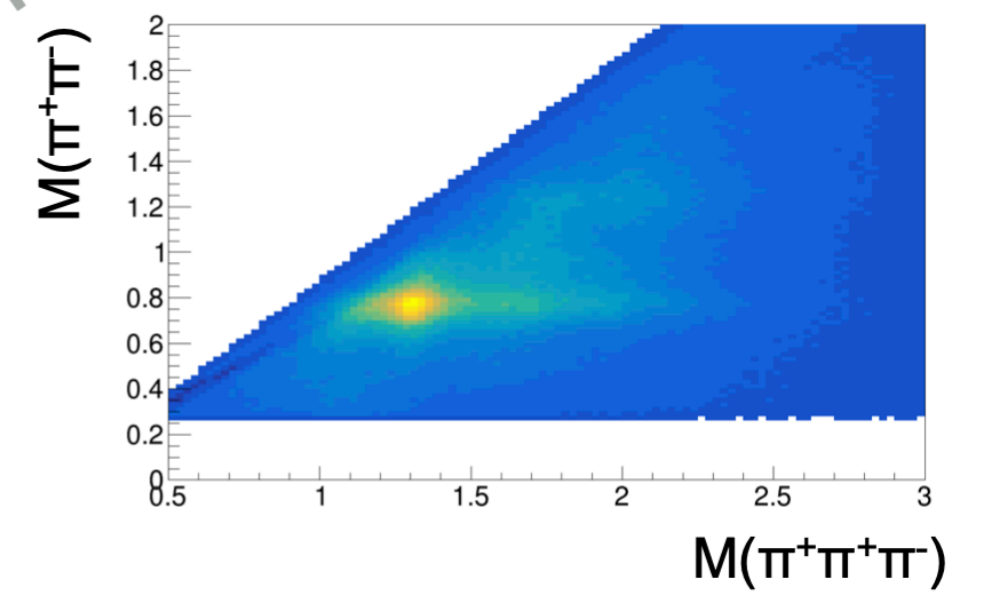
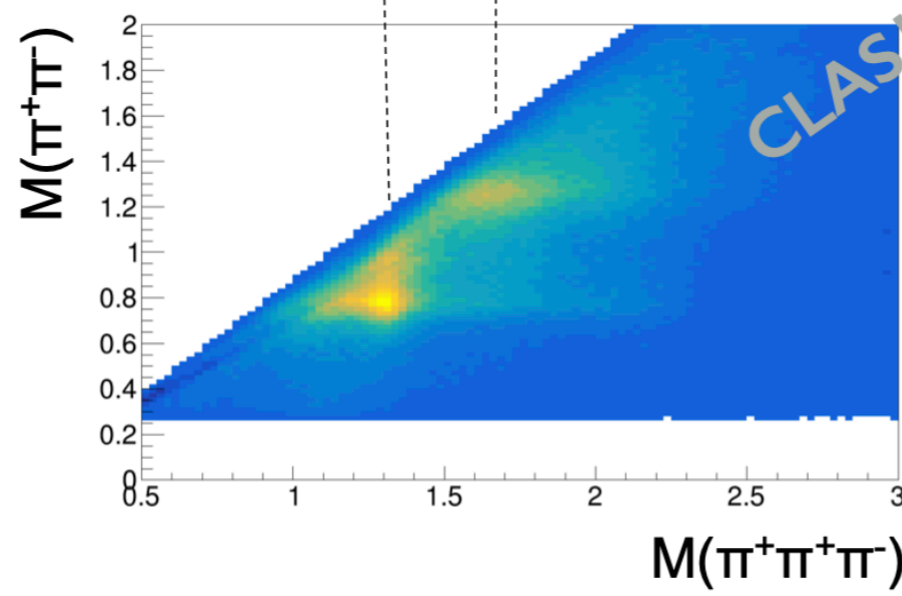
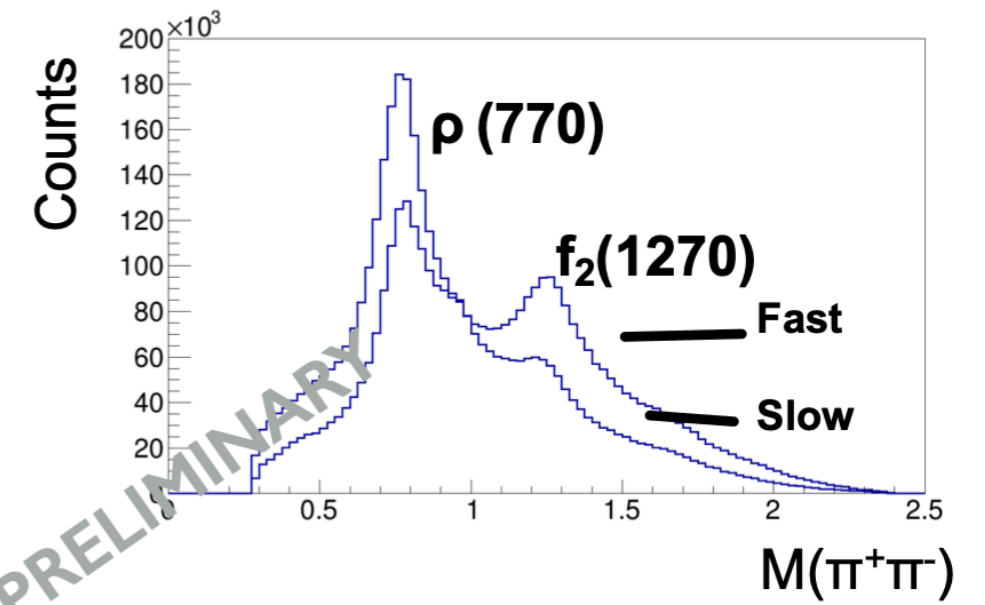
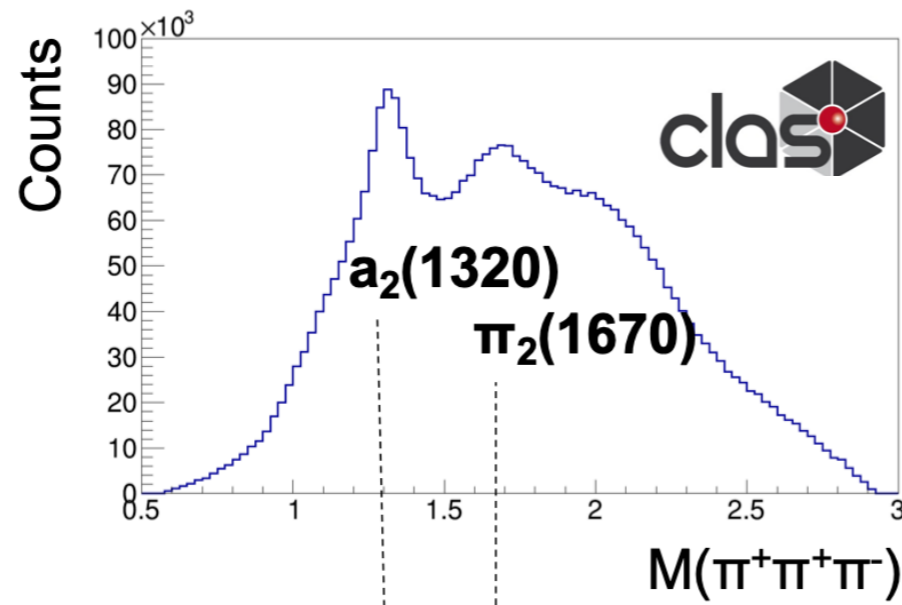
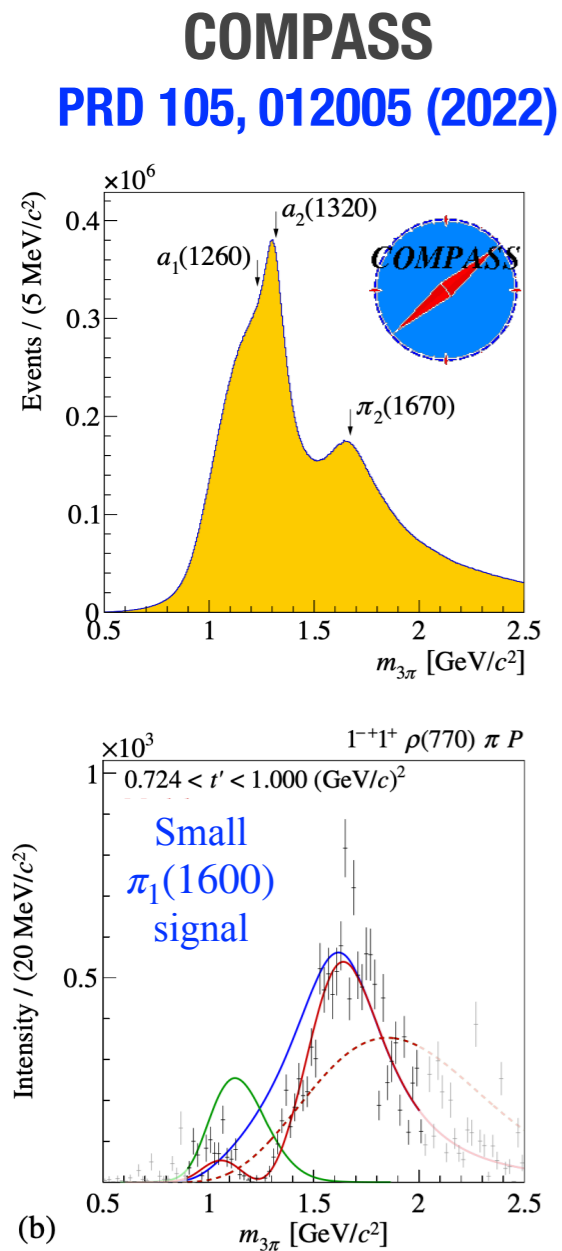

- * Unique $\pi^+\pi^+\pi^-$ dataset from only a portion of CLAS12 beam time to compare with observations of $\pi_1(1600)$ signal from COMPASS

Mapping the meson spectrum

PRD 88 (2013) 094505

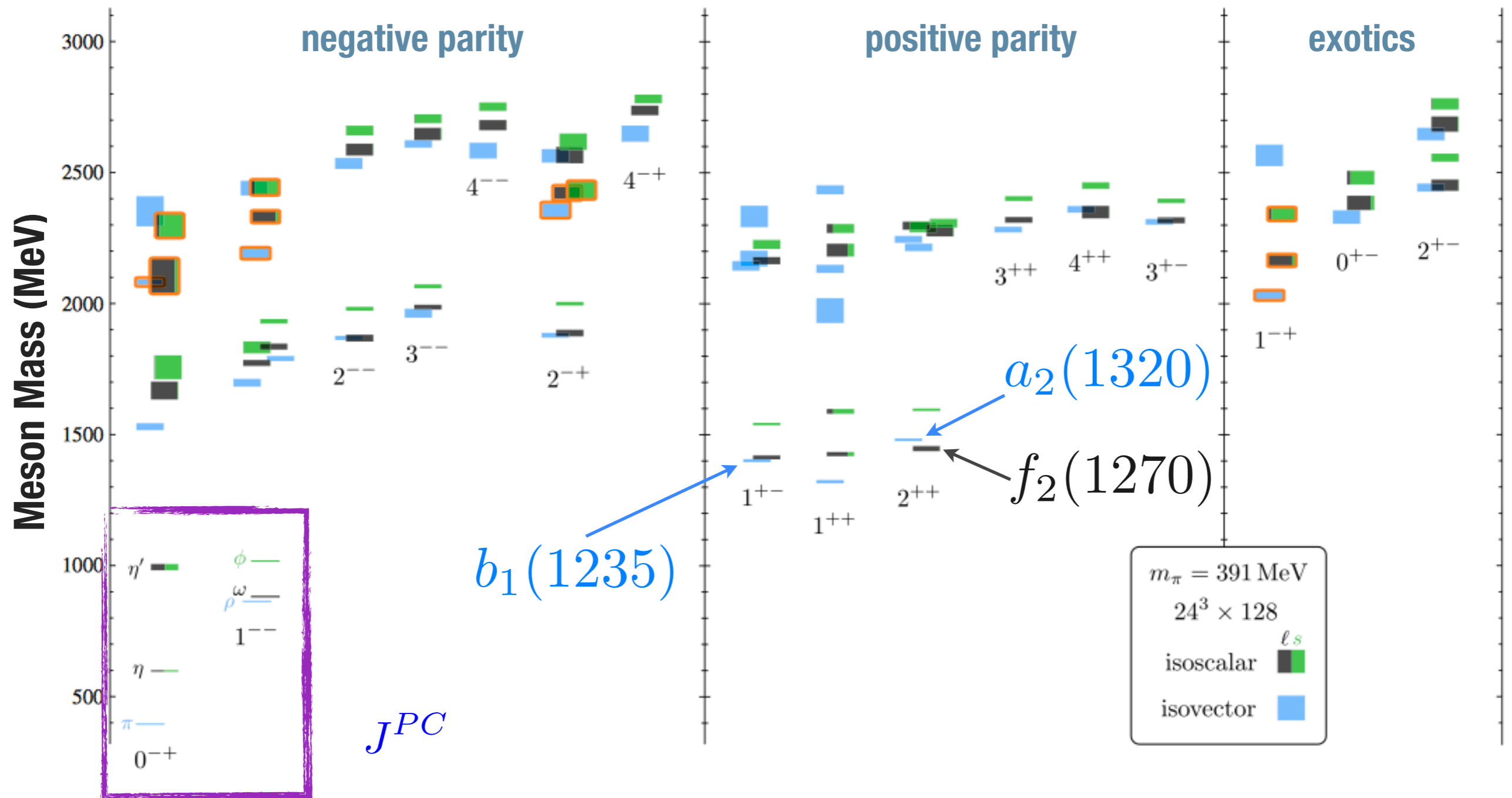

- * Already studying polarization observables for **“simple” final states**
- * Beginning to identify **known mesons** in multi-particle final states

Strangeness program

- * Lattice predicts **strange** and **light** quark content for mesons
- * Search for a **pattern** of hybrid states in many final states
- * Requires clean identification of charged pions and kaons

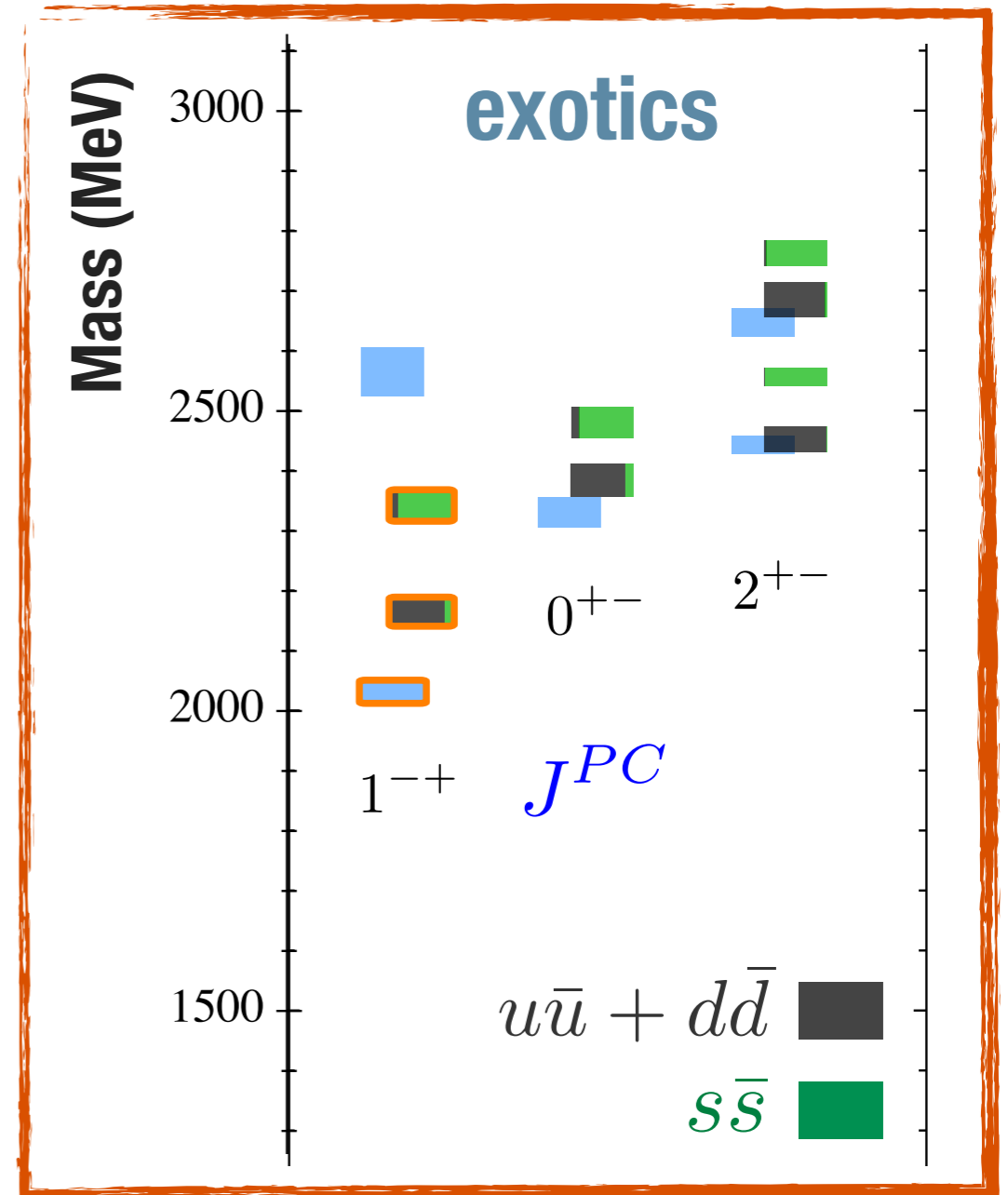

	Approximate Mass (MeV)	J^{PC}	Final States
π_1	1900	1^{-+}	$\omega\pi\pi^\dagger, 3\pi^\dagger, 5\pi, \eta 3\pi^\dagger, \eta'\pi^\dagger$
η_1	2100	1^{-+}	$4\pi, \eta 4\pi, \eta\eta\pi\pi^\dagger$
η'_1	2300	1^{-+}	$KK\pi\pi^\dagger, KK\pi^\dagger, KK\omega^\dagger$

Strangeness program: decay patterns

- * Experimentally infer quark flavor composition through branching ratios to strange and non-strange decays

$$\frac{\mathcal{B}(f_2'(1525) \rightarrow \pi\pi)}{\mathcal{B}(f_2'(1525) \rightarrow KK)} \approx 0.009$$

$$\frac{\mathcal{B}(f_2(1270) \rightarrow \pi\pi)}{\mathcal{B}(f_2(1270) \rightarrow KK)} \approx 20$$

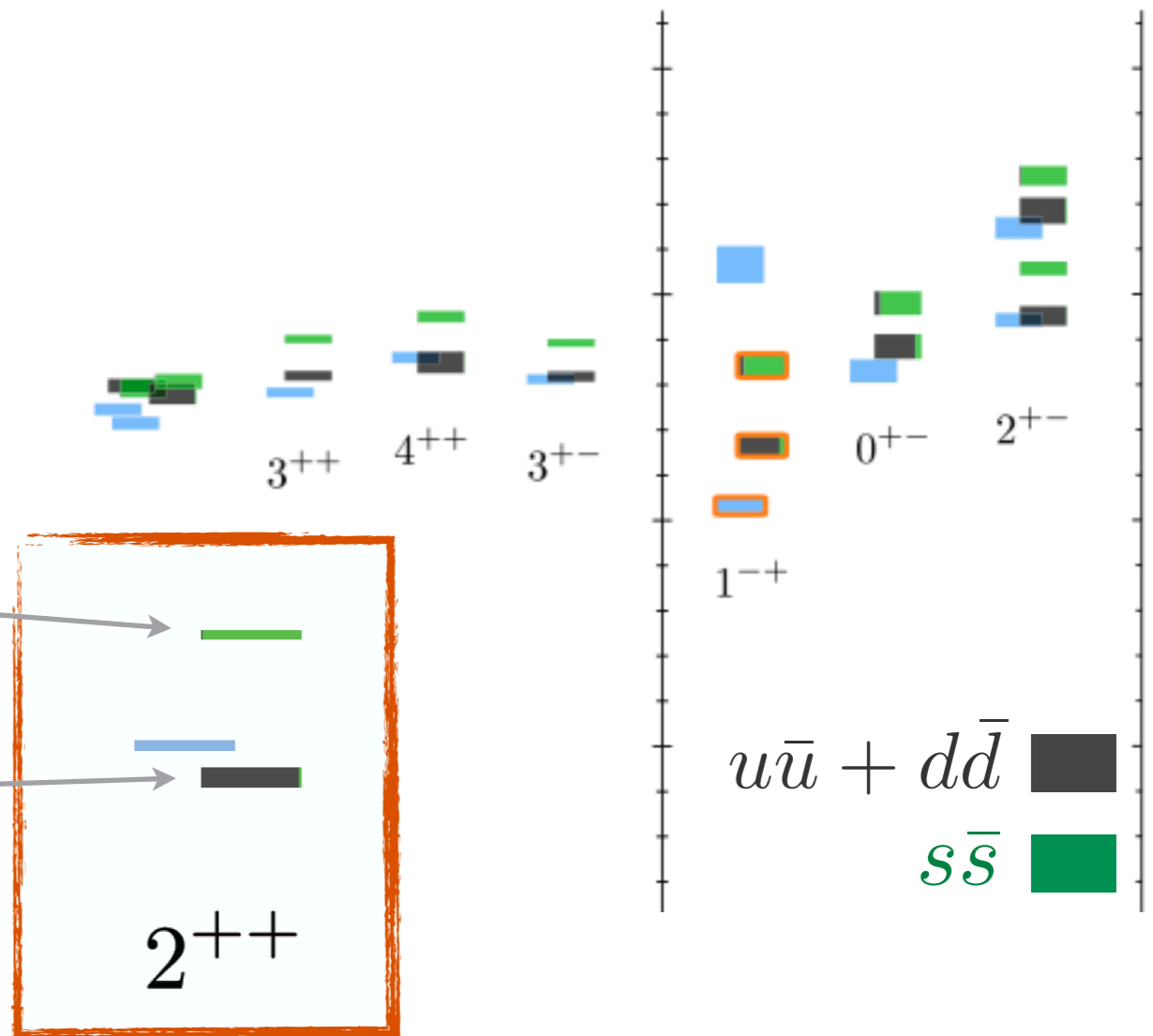

- * Consistent with lattice QCD mixing angle for 2^{++} , and predictions for hybrids
- * Need capability to detect strange and non-strange to infer hybrid flavor content

Strangeness program: $Y(2175)$

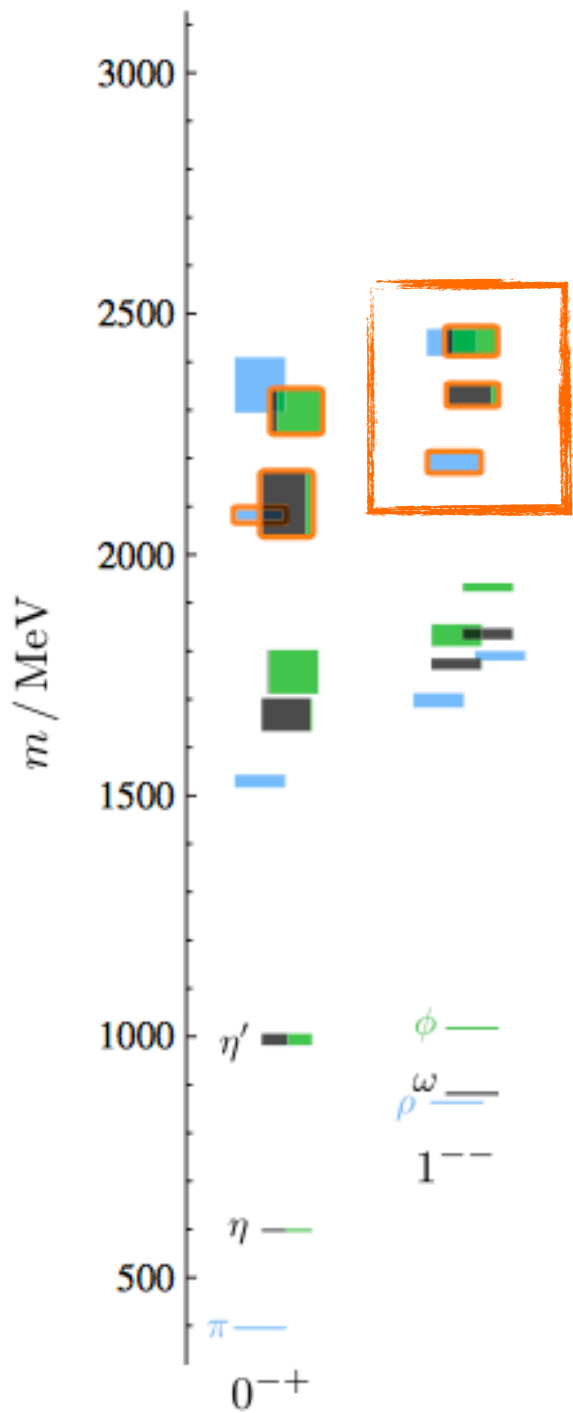

Belle: $e^+e^- \rightarrow \phi\pi^+\pi^-(\gamma)$

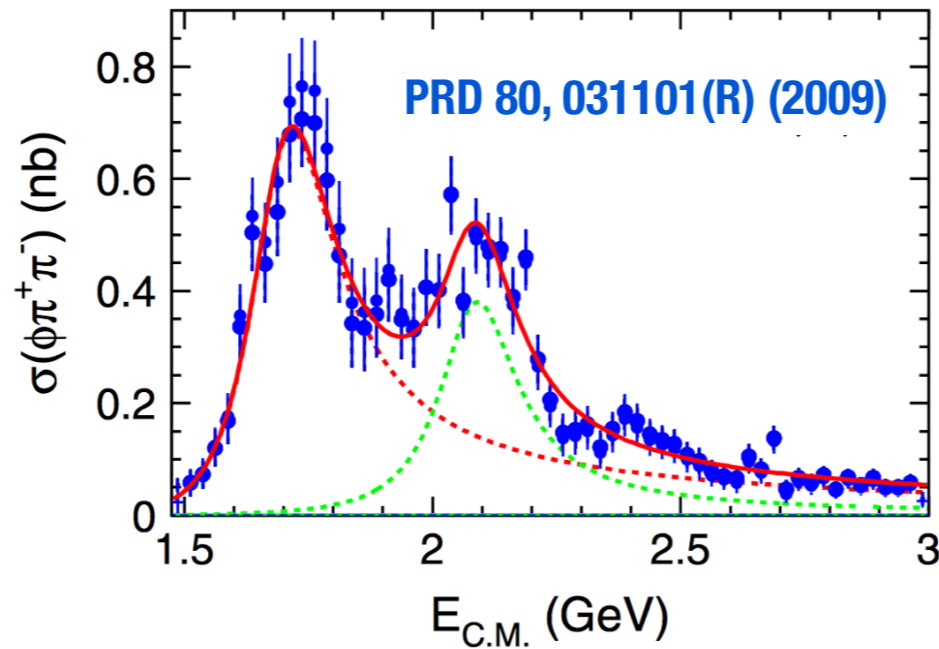

BES III: $J/\psi \rightarrow \eta\phi\pi^+\pi^-$

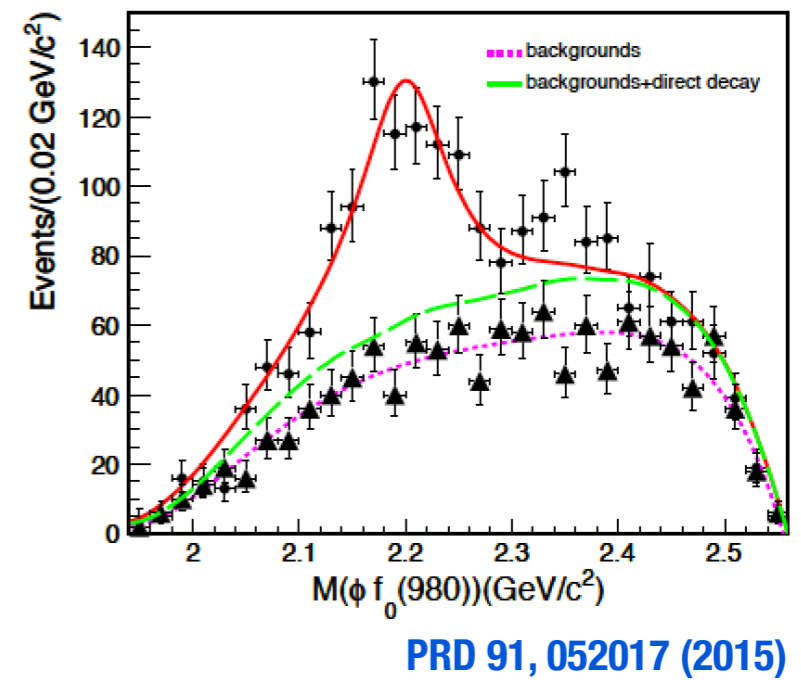

* $Y(2175)$ $J^{PC}=1^{--}$ state observed by 3 experiments

* Decay pattern similar to $Y(4260)$ in charmonium

$$Y(2175) \rightarrow \phi\pi^+\pi^- \quad Y(4260) \rightarrow J/\psi\pi^+\pi^-$$

* Is it a supernumerary state in the strangeonium spectrum? Possibly a hybrid?

Strangeness program: $\Upsilon(2175)$

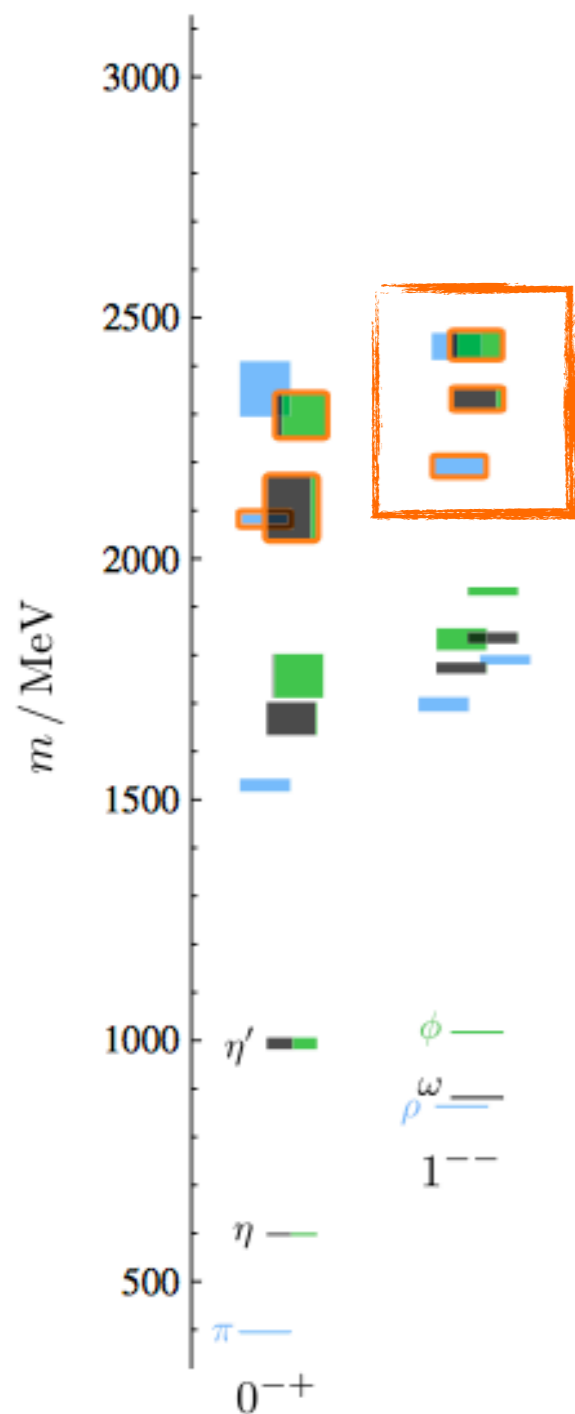

GlueX: $\gamma p \rightarrow \phi \pi^+ \pi^- p$

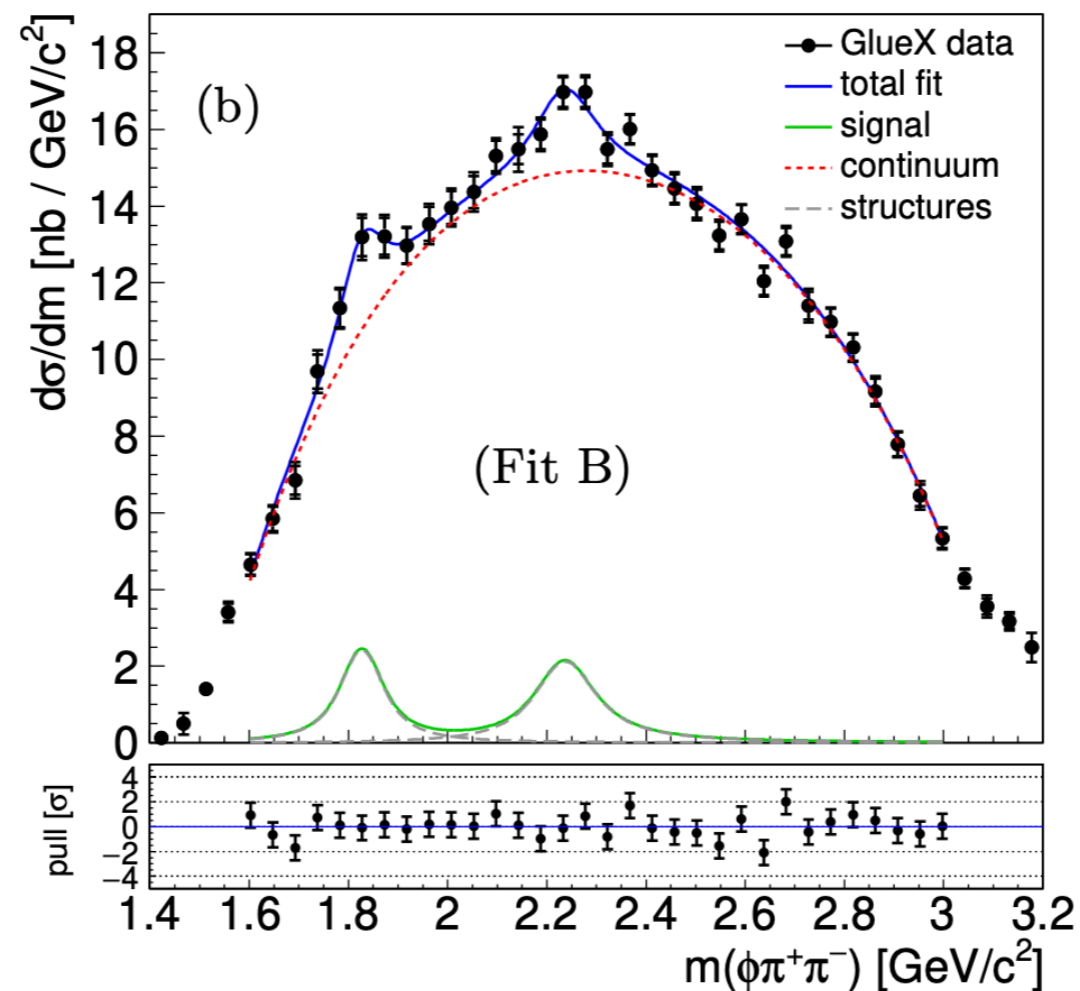

- * Don't observe the $\Upsilon(2175)$ in photoproduction!
- * Instead find structure at ~ 2.24 GeV

Strange hadron spectroscopy

* JLab strange quark program upgrades

CLAS12

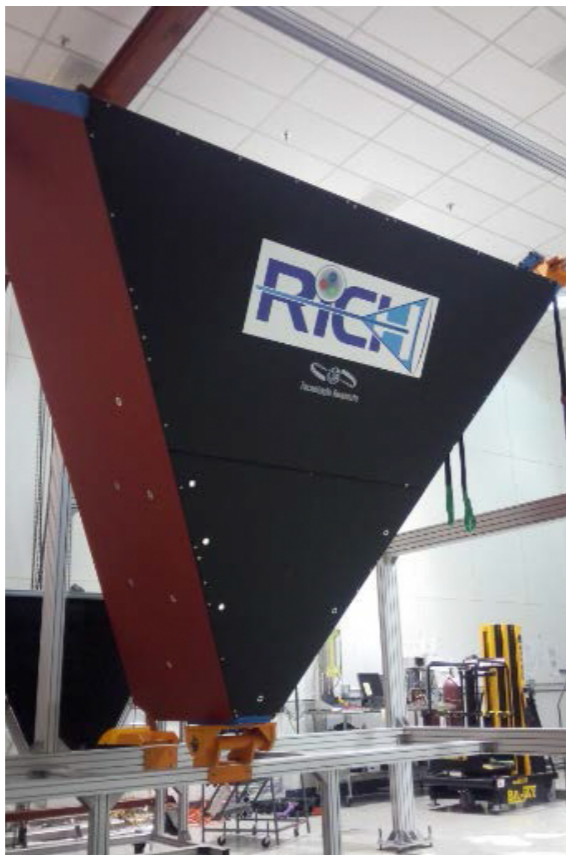

GLUEX

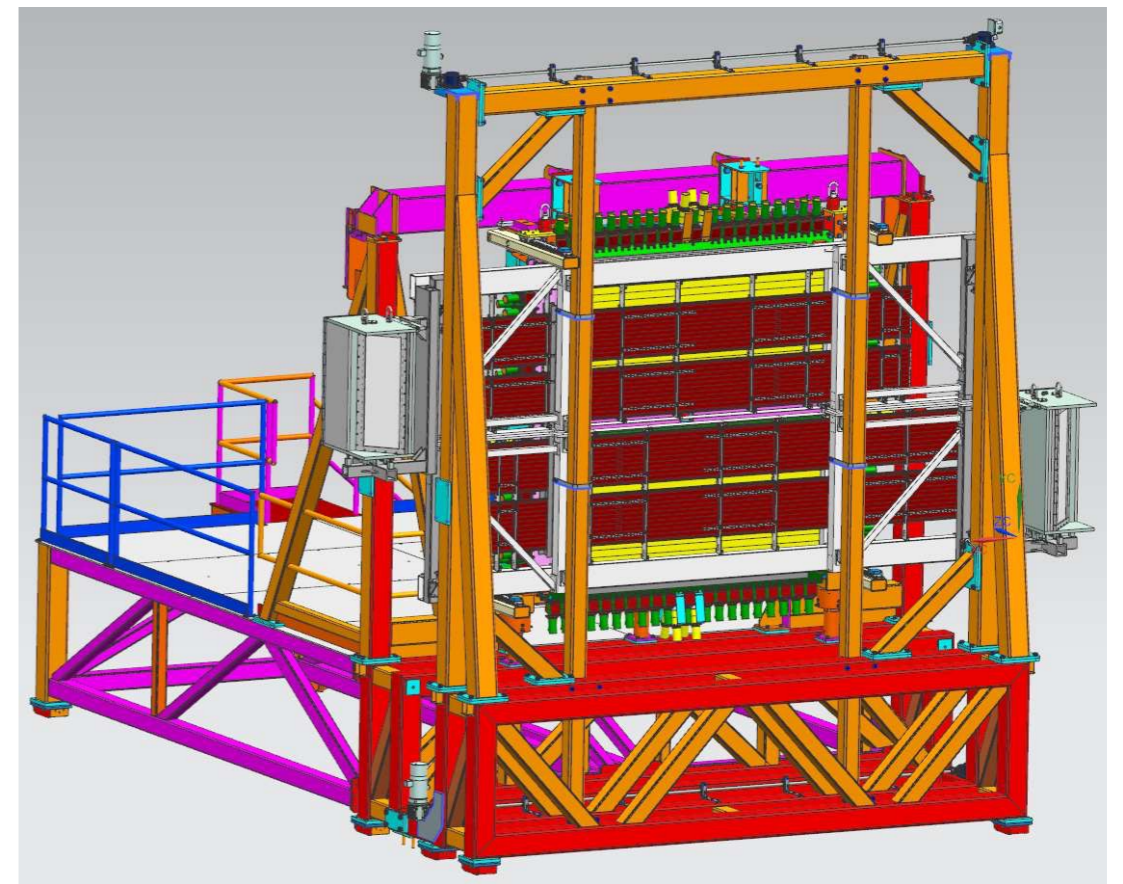

Charged particle identification

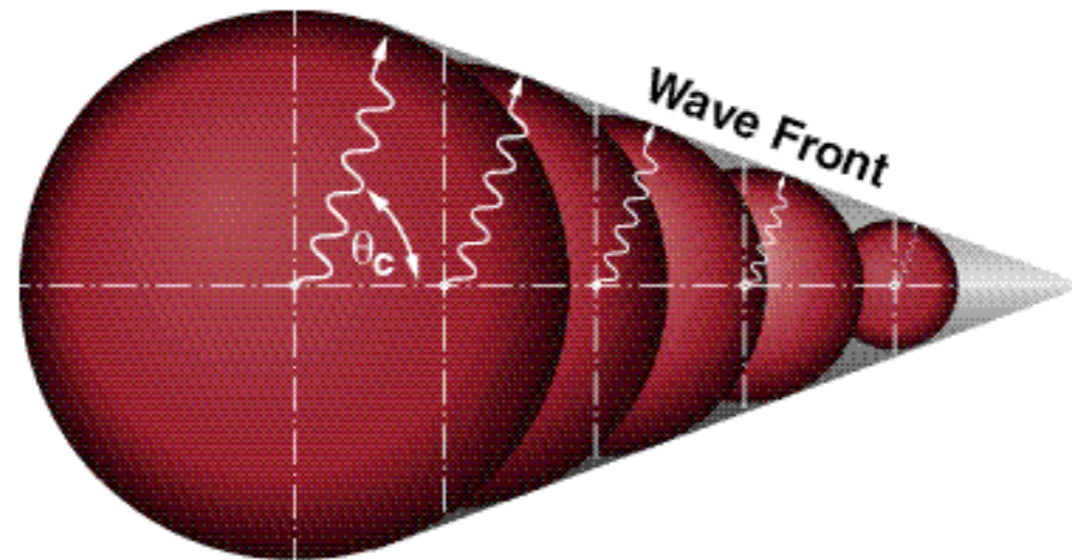

- * Charged particles traveling faster than the speed of light in a medium emit Cherenkov light

- * Wavelength dependence:

$$N_{\gamma} \sim \frac{1}{\lambda^2}$$

- * Cherenkov angle:

$$\cos\theta_c = \frac{1}{\beta n(\lambda)}$$

- * Determine $\beta = v/c$, separate kaons from pions by difference in mass

Nuclear Reactor

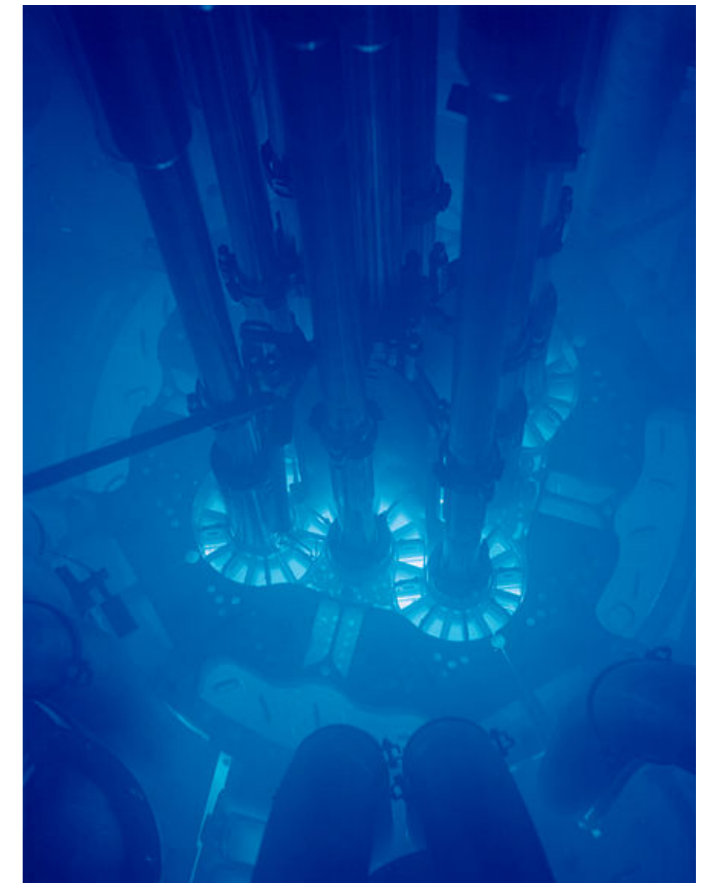

Particle Identification: DIRC

- * **DIRC**: Detection of Internally Reflected Cherenkov Light
- * Pioneered for BaBar detector at SLAC PEP-II
- * Image photons to measure Cherenkov angle

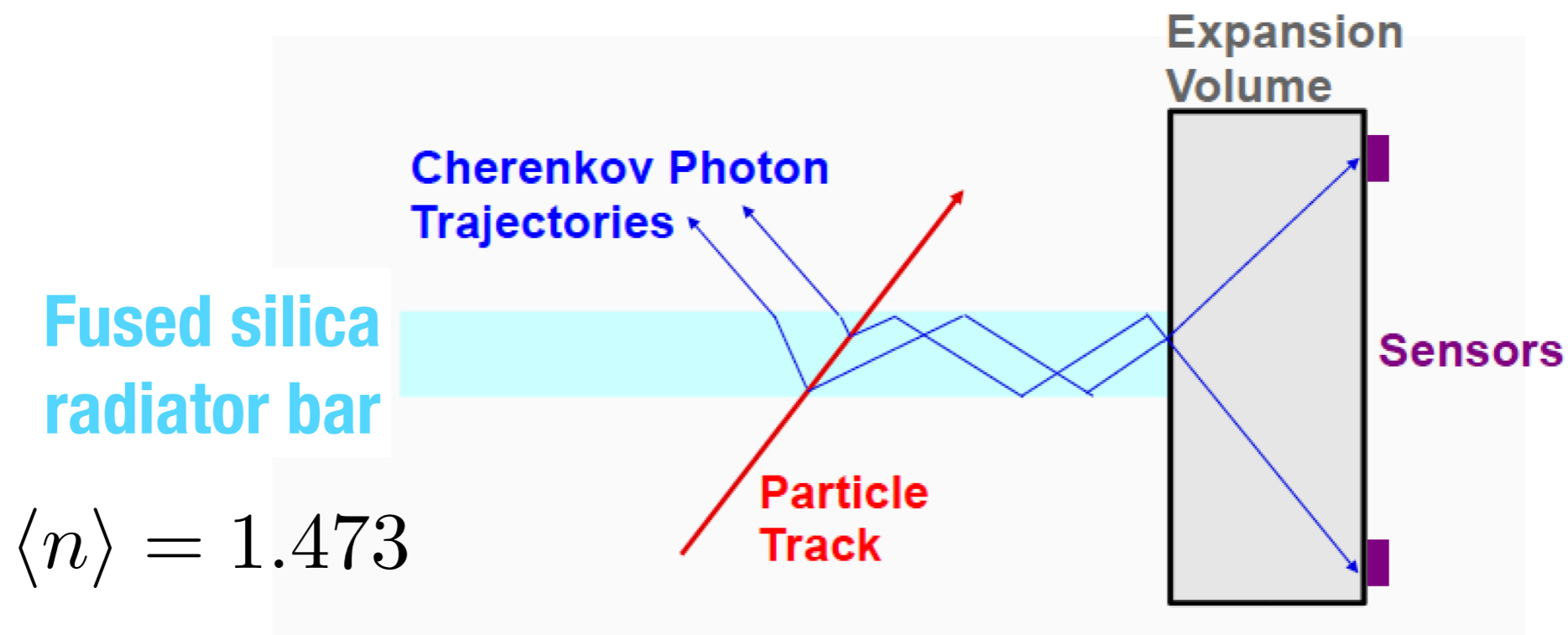
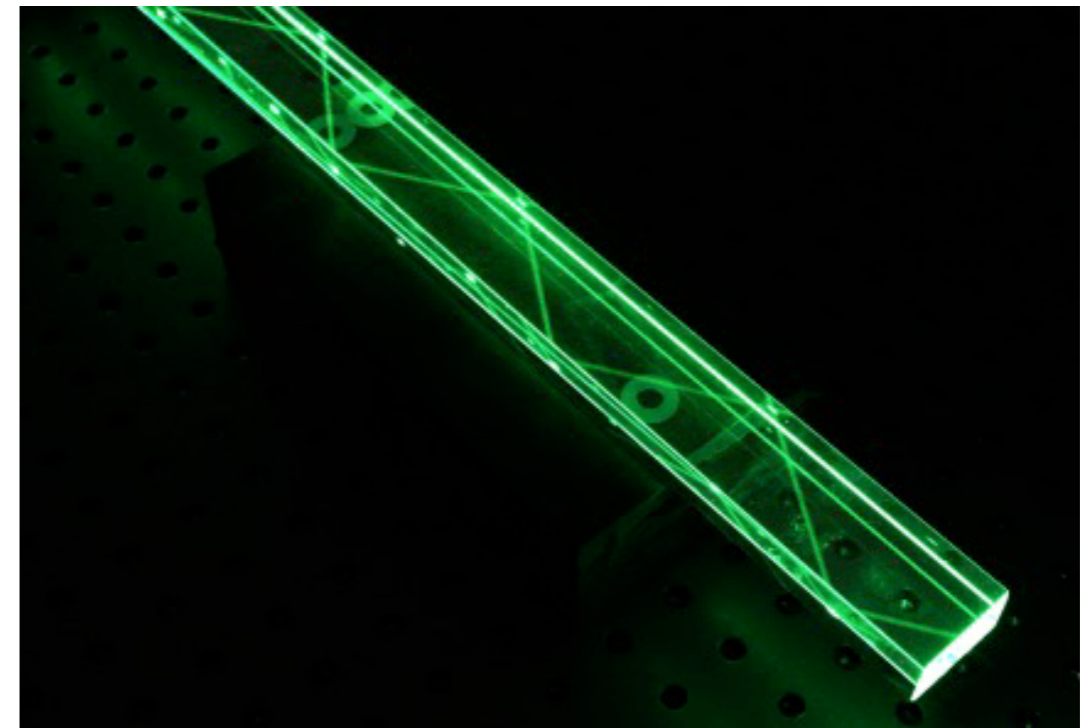

Particle Identification: DIRC

- * **DIRC:** Detection of Internally Reflected Cherenkov Light
- * Pioneered for BaBar detector at SLAC PEP-II
- * Image photons to measure Cherenkov angle

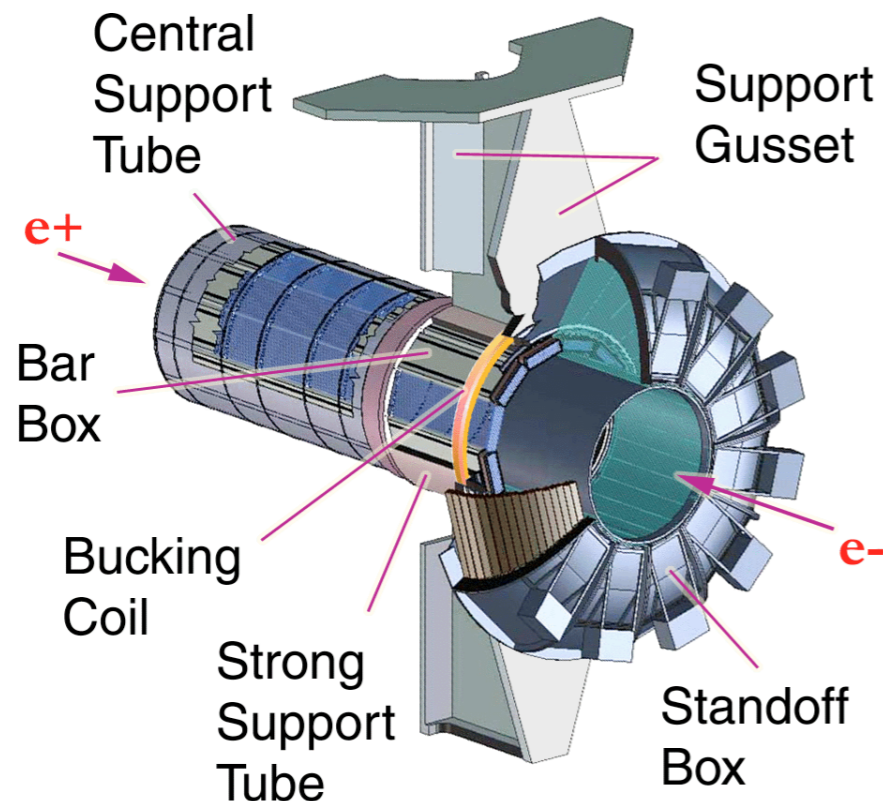
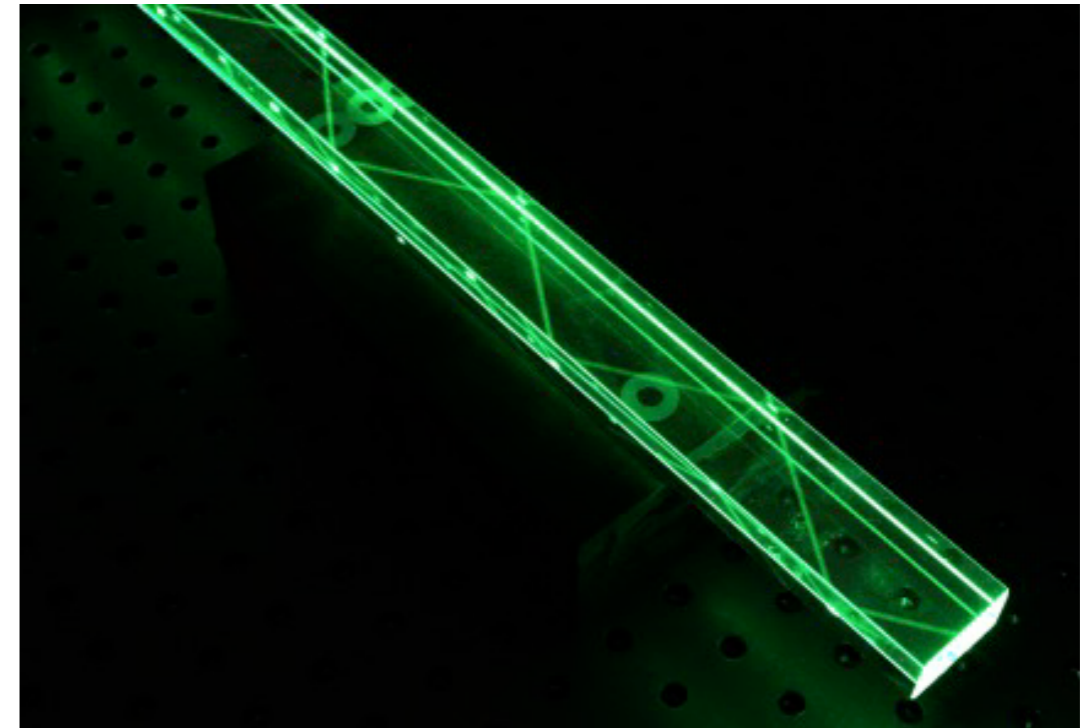

BaBar DIRC Event Display

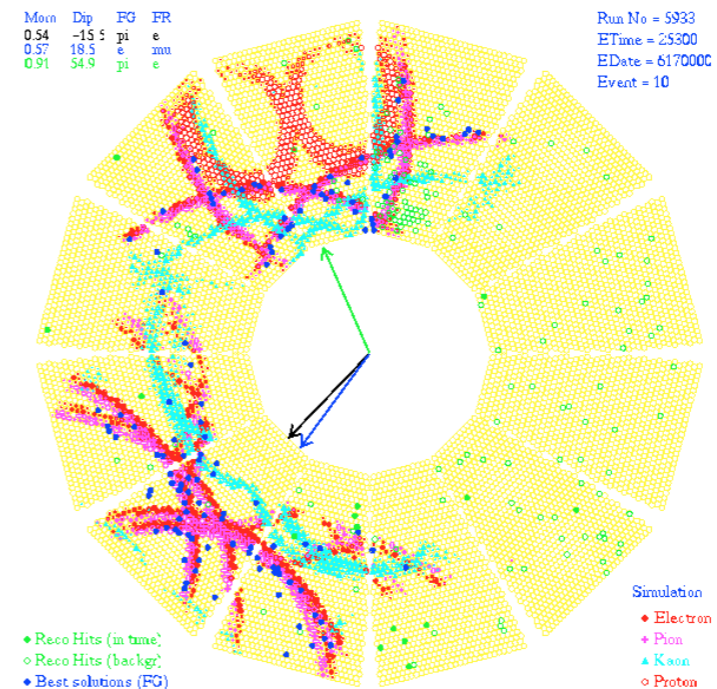

Particle Identification: DIRC

- * **DIRC:** Detection of Internally Reflected Cherenkov Light
- * Pioneered for BaBar detector at SLAC PEP-II
- * Image photons to measure Cherenkov angle

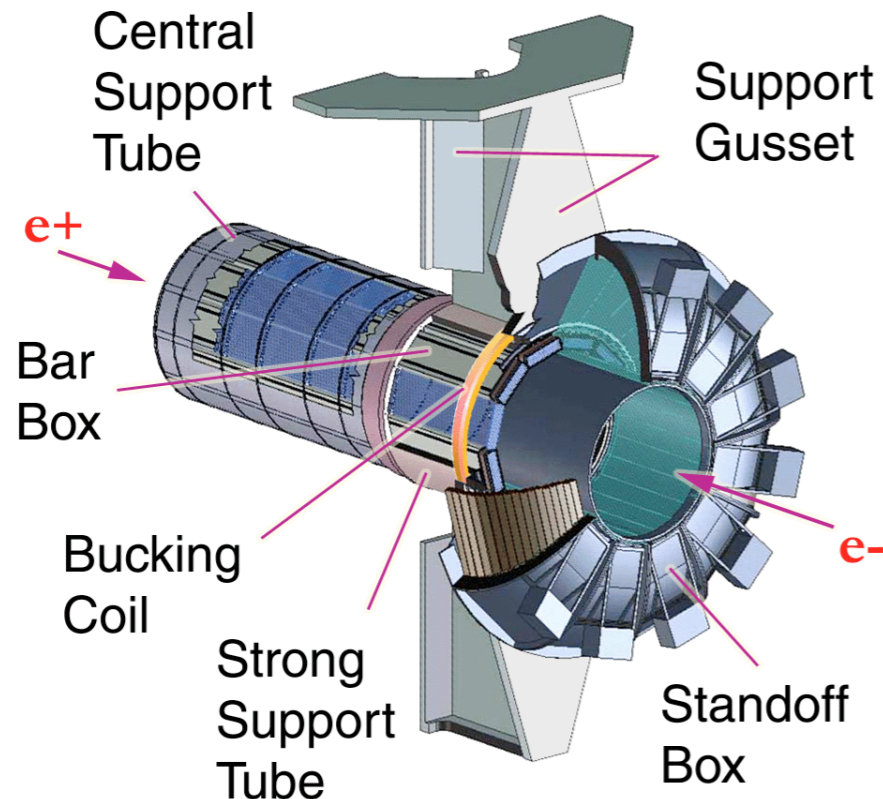
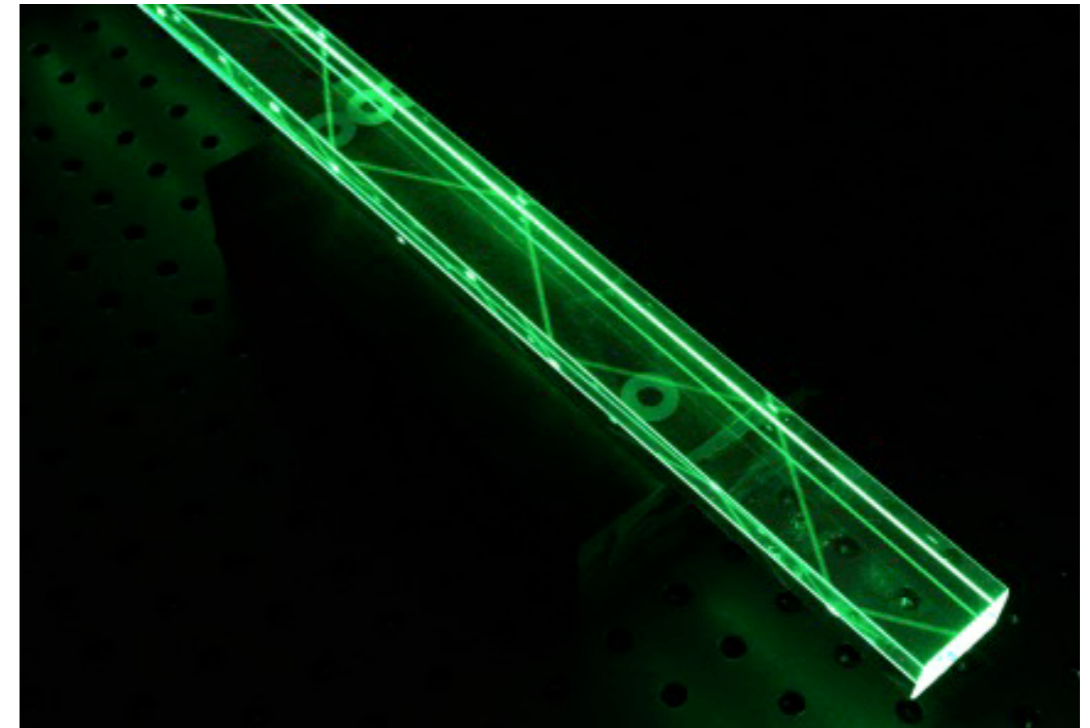

**BaBar finished data
taking in 2008**





Shipped from SLAC -> JLab in 2018

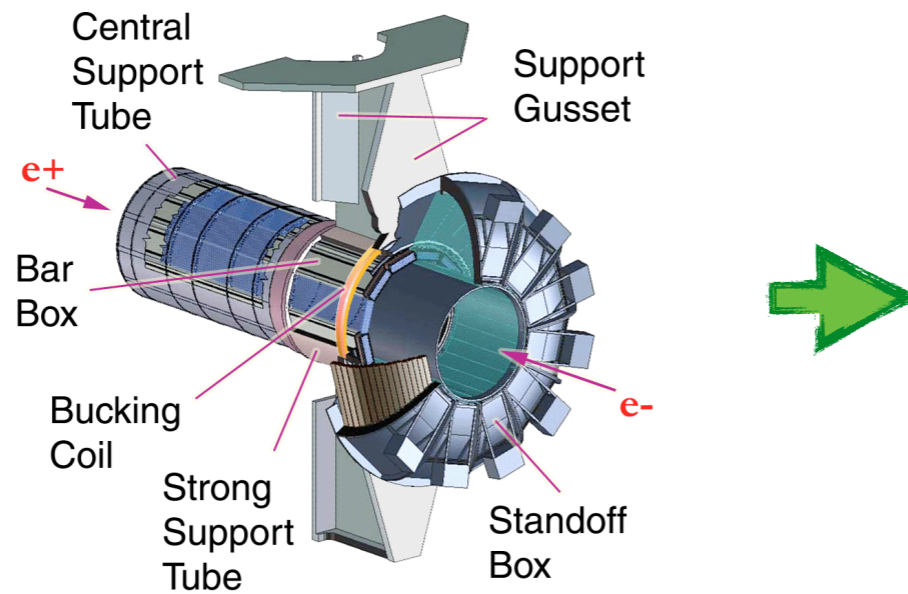

Follow the trip:  @GlueX_DIRC

Photon hit patterns: **kaons**

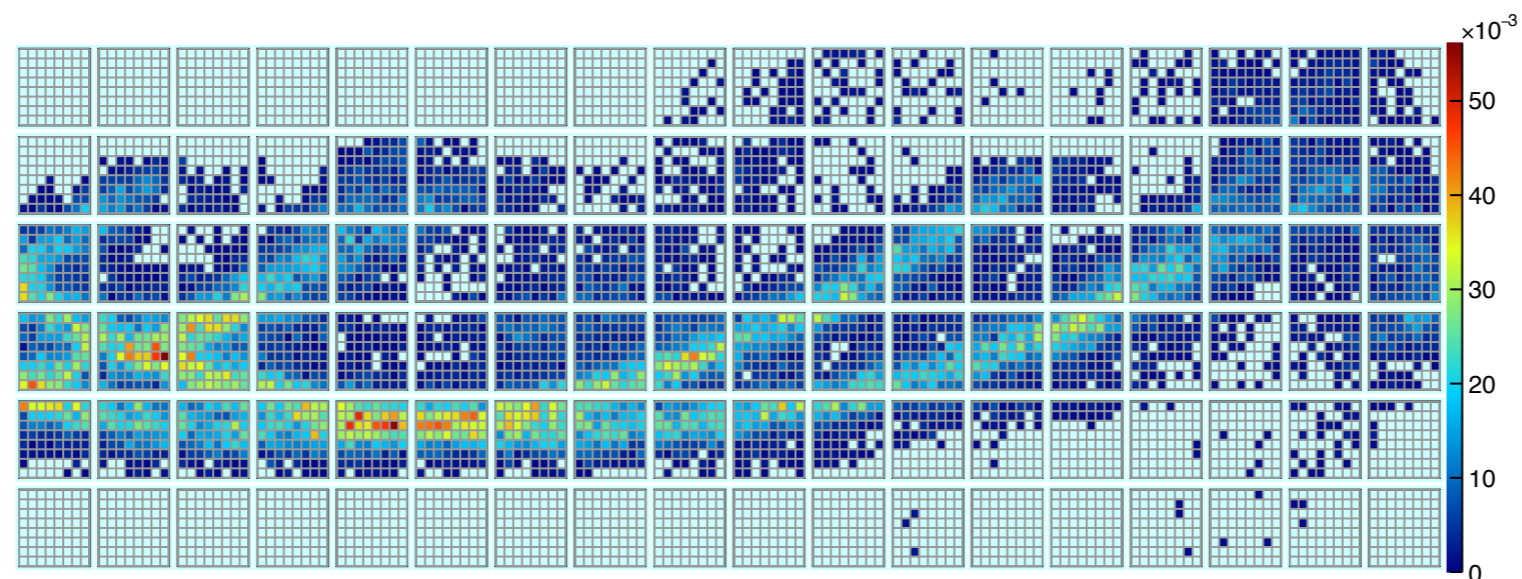

GlueX-II
Data

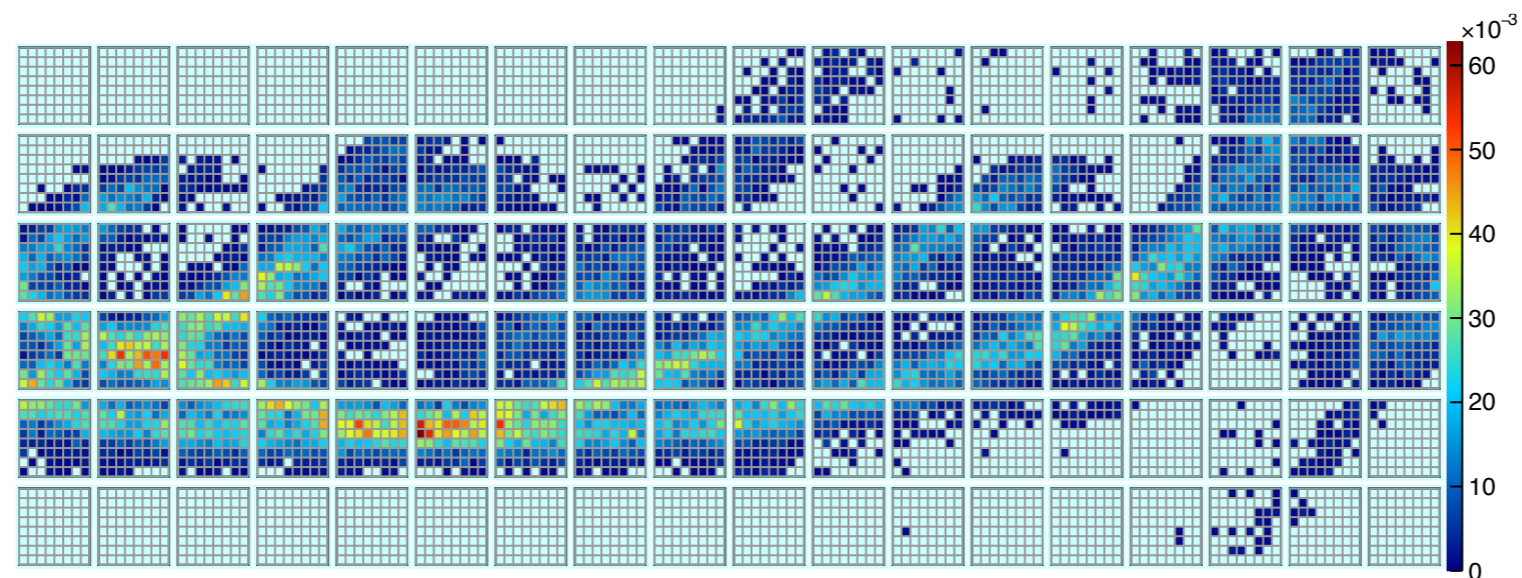

Geant4
Simulation

- * Hit patterns from 1000 identified **kaons** tracks with $p = 3.5 \text{ GeV}/c$
- * Good agreement between beam data and simulations

Summary

- * The **GLUEX** experiment is commissioned and the initial meson program is well underway
- * Early measurements aimed at understanding the meson production mechanism through polarization observables
- * Cherenkov detectors provided access to strange quark sector enhancing the discovery potential for hybrid mesons

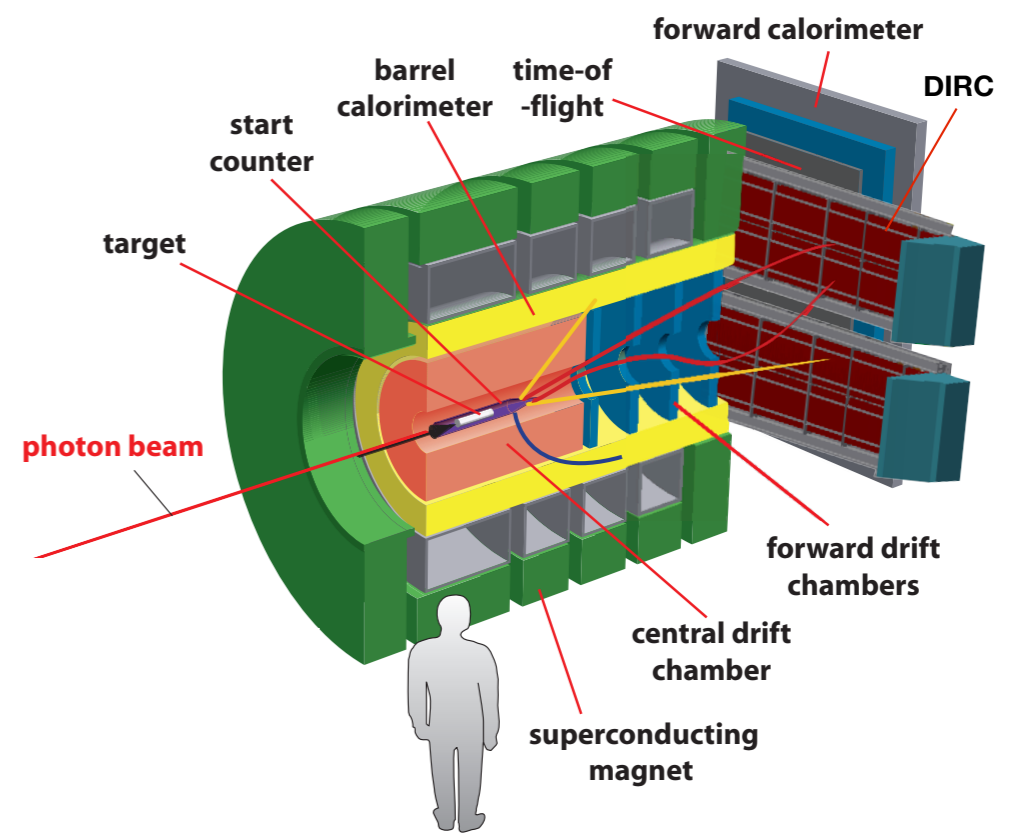
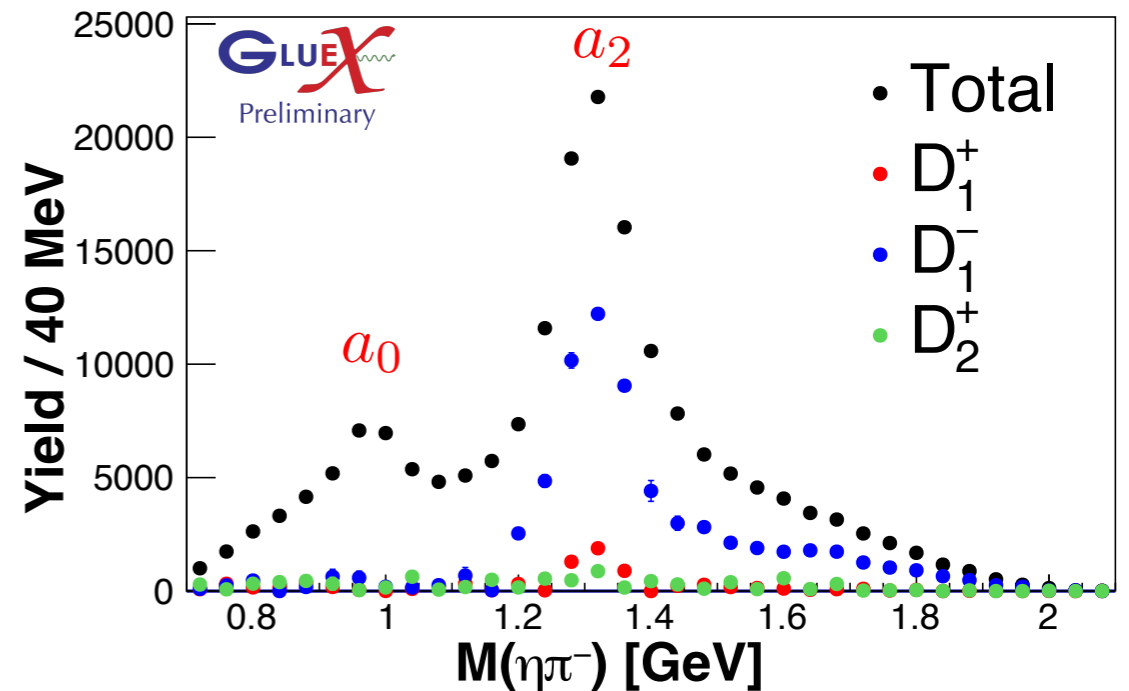

Supported by DE-SC0018224

Further Reading

- * **Light isovector resonances in $\pi^- p \rightarrow \pi^- \pi^- \pi^+$**
Compass Collaboration
[arXiv:1802.05913]
- * **Searching for the rules that govern hadron construction**
Matt Shepherd, Jozef J. Dudek, and Ryan Mitchell
Nature 534 (2016) 487
- * **Hybrid mesons**
Curtis A. Meyer and Eric S Swanson, Progress in Particle and Nuclear Physics 82, 21-58 (2015)

Backup

Exotic J^{PC} decays

C. A. Meyer and E. S. Swanson,
Progress in Particle and Nuclear Physics B82, 21, (2015)

	Approximate Mass (MeV)	J^{PC}	Total Width MeV		Allowed Decay Modes
			PSS	IKP	
π_1	1900	1^{-+}	81 – 168	117	$b_1\pi, \pi\rho, \pi f_1, \pi\eta, \pi\eta', \eta a_1, \pi\eta(1295)$
η_1	2100	1^{-+}	59 – 158	107	$\pi a_1, \pi a_2, \eta f_1, \eta f_2, \pi\pi(1300), \eta\eta', KK_1^A, KK_1^B$
η'_1	2300	1^{-+}	95 – 216	172	$KK_1^B, KK_1^A, KK^*, \eta\eta'$
b_0	2400	0^{+-}	247 – 429	665	$\pi\pi(1300), \pi h_1, \rho f_1, \eta b_1$
h_0	2400	0^{+-}	59 – 262	94	$\pi b_1, \eta h_1, KK(1460)$
h'_0	2500	0^{+-}	259 – 490	426	$KK(1460), KK_1^A, \eta h_1$
b_2	2500	2^{+-}	5 – 11	248	$\pi a_1, \pi a_2, \pi h_1, \eta\rho, \eta b_1, \rho f_1$
h_2	2500	2^{+-}	4 – 12	166	$\pi\rho, \pi b_1, \eta\omega, \omega b_1$
h'_2	2600	2^{+-}	5 – 18	79	$KK_1^B, KK_1^A, KK_2^*, \eta h_1$

* Predictions for the spectrum of hybrids from lattice, **but decay predictions are model dependent**

1⁻⁺ channels observed

$$\pi\rho \rightarrow \pi\pi\pi$$

$$\pi\eta' \rightarrow \eta\pi\pi\pi$$

$$\pi b_1 \rightarrow \omega\pi\pi$$

Exotic J^{PC} decays

C. A. Meyer and E. S. Swanson,
Progress in Particle and Nuclear Physics B82, 21, (2015)

	Approximate Mass (MeV)	J^{PC}	Total Width MeV		Allowed Decay Modes
			PSS	IKP	
π_1	1900	1^{-+}	81 – 168	117	$b_1\pi, \pi\rho, \pi f_1, \pi\eta, \pi\eta', \eta a_1, \pi\eta(1295)$
η_1	2100	1^{-+}	59 – 158	107	$\pi a_1, \pi a_2, \eta f_1, \eta f_2, \pi\pi(1300), \eta\eta', KK_1^A, KK_1^B$
η_1'	2300	1^{-+}	95 – 216	172	$KK_1^B, KK_1^A, KK^*, \eta\eta'$
b_0	2400	0^{+-}	247 – 429	665	$\pi\pi(1300), \pi h_1, \rho f_1, \eta b_1$
h_0	2400	0^{+-}	59 – 262	94	$\pi b_1, \eta h_1, KK(1460)$
h_0'	2500	0^{+-}	259 – 490	426	$KK(1460), KK_1^A, \eta h_1$
b_2	2500	2^{+-}	5 – 11	248	$\pi a_1, \pi a_2, \pi h_1, \eta\rho, \eta b_1, \rho f_1$
h_2	2500	2^{+-}	4 – 12	166	$\pi\rho, \pi b_1, \eta\omega, \omega b_1$
h_2'	2600	2^{+-}	5 – 18	79	$KK_1^B, KK_1^A, KK_2^*, \eta h_1$

* Predictions for the spectrum of hybrids from lattice, **but decay predictions are model dependent**

1-+ channels observed

$$\begin{aligned}\pi\rho &\rightarrow \pi\pi\pi \\ \pi\eta' &\rightarrow \eta\pi\pi\pi \\ \pi b_1 &\rightarrow \omega\pi\pi\end{aligned}$$

Some additional 1-+ channels

$$\begin{aligned}\pi a_2 &\rightarrow \eta\pi\pi & \eta f_1 &\rightarrow \eta\eta\pi\pi \\ & & KK^* &\rightarrow KK\pi \\ & & KK_1(1270) &\rightarrow KK\pi\pi\end{aligned}$$

Evidence for 1^{-+} exotics

* $\pi_1(1400) \rightarrow \eta\pi$

* Not likely a hybrid: dynamical origin or 4-quark state?

* $\pi_1(1600) \rightarrow \pi\pi\pi, \eta'\pi, b_1\pi, \text{ etc.}$

Compass: PLB 740 (2015) 303

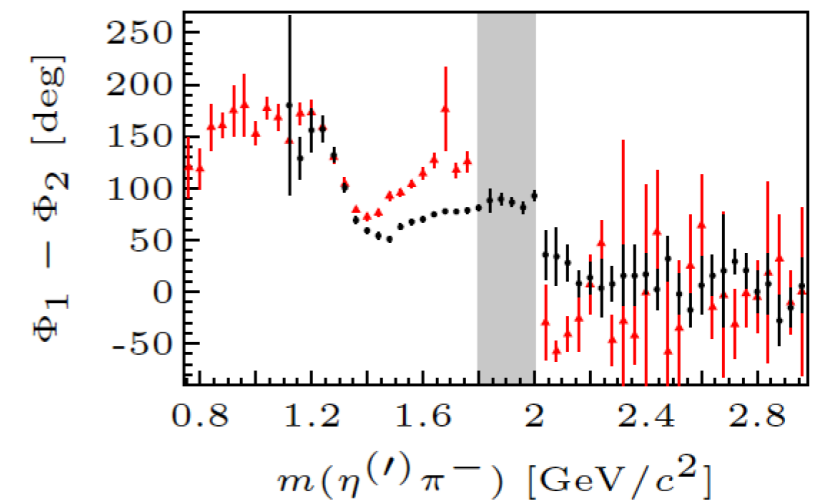
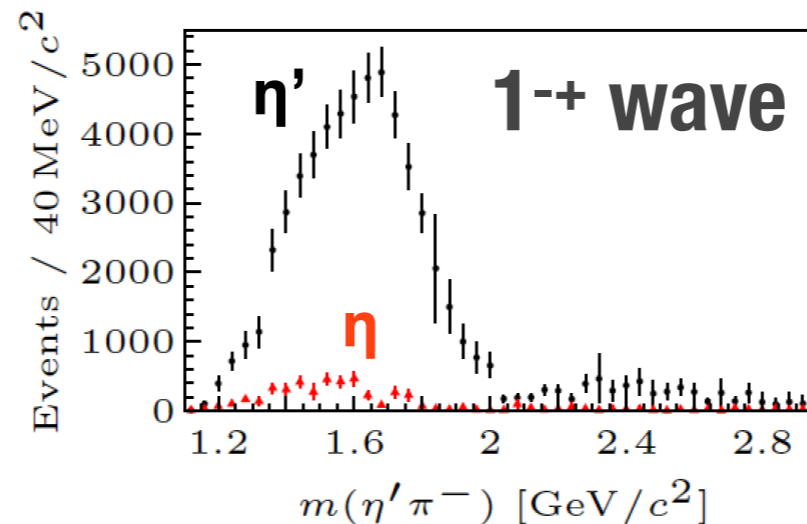
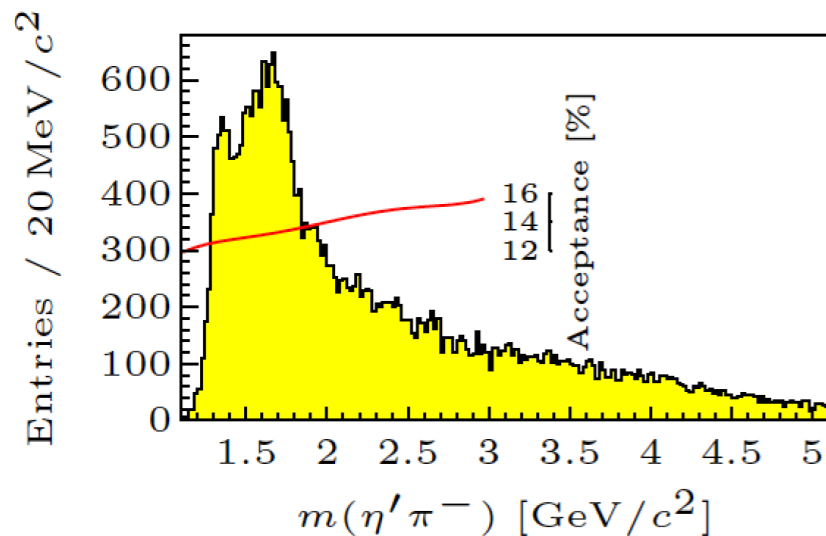

Evidence for 1^{-+} exotics

* $\pi_1(1400) \rightarrow \eta\pi$

* Not likely a hybrid: dynamical origin or 4-quark state?

* $\pi_1(1600) \rightarrow \pi\pi\pi, \eta'\pi, b_1\pi, \text{ etc.}$

Compass: PRL 104, 241803 (2010)

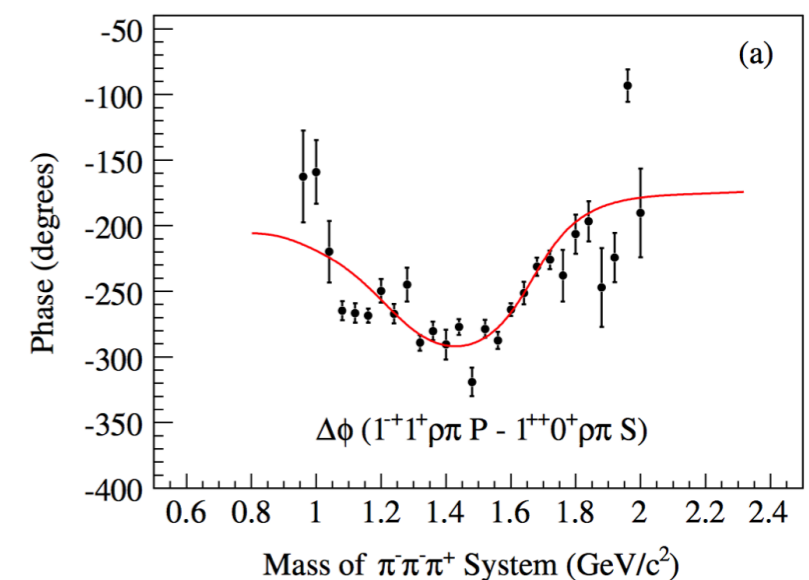
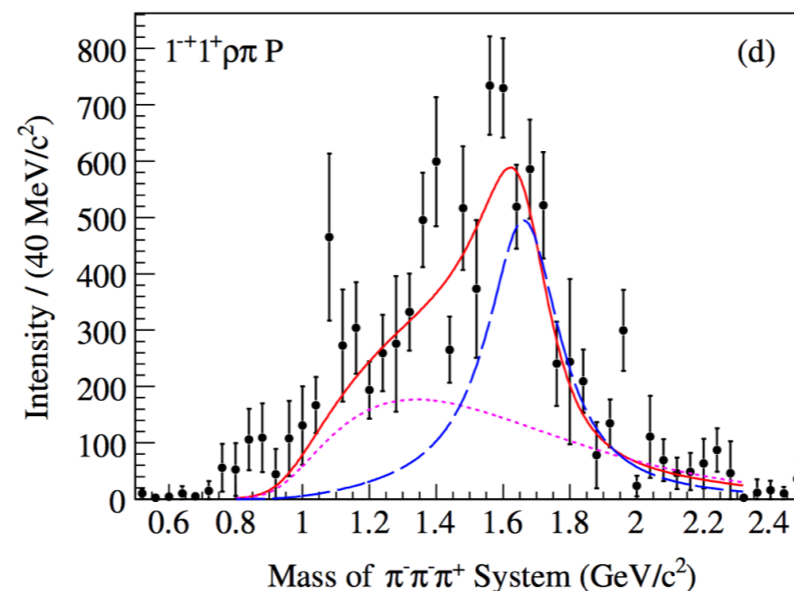
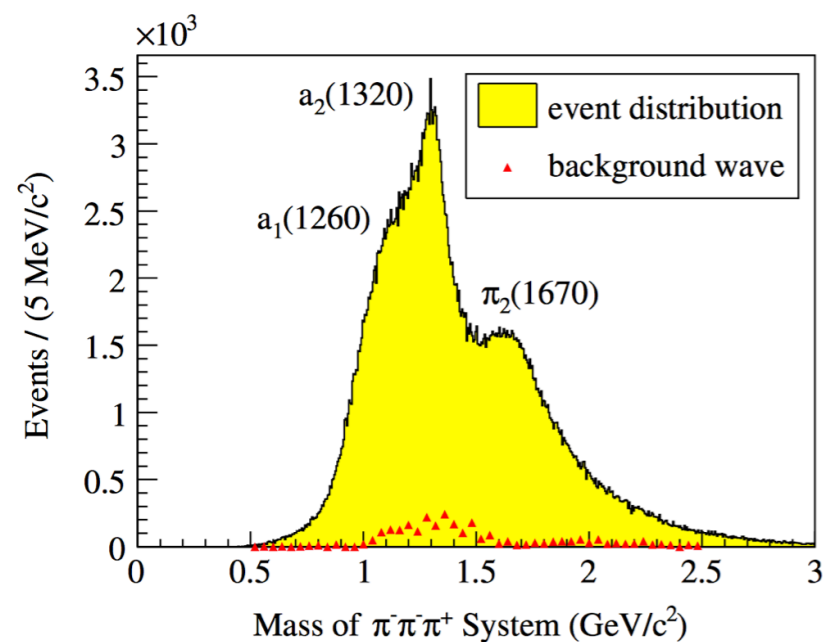

Evidence for 1^{-+} exotics

* $\pi_1(1400) \rightarrow \eta\pi$

* Not likely a hybrid: dynamical origin or 4-quark state?

* $\pi_1(1600) \rightarrow \pi\pi\pi, \eta'\pi, b_1\pi, \text{etc.}$

E852: PRD 73 (2006) 072001

Found no exotic when using a larger set of partial waves (ie. “high wave”) than previous analysis

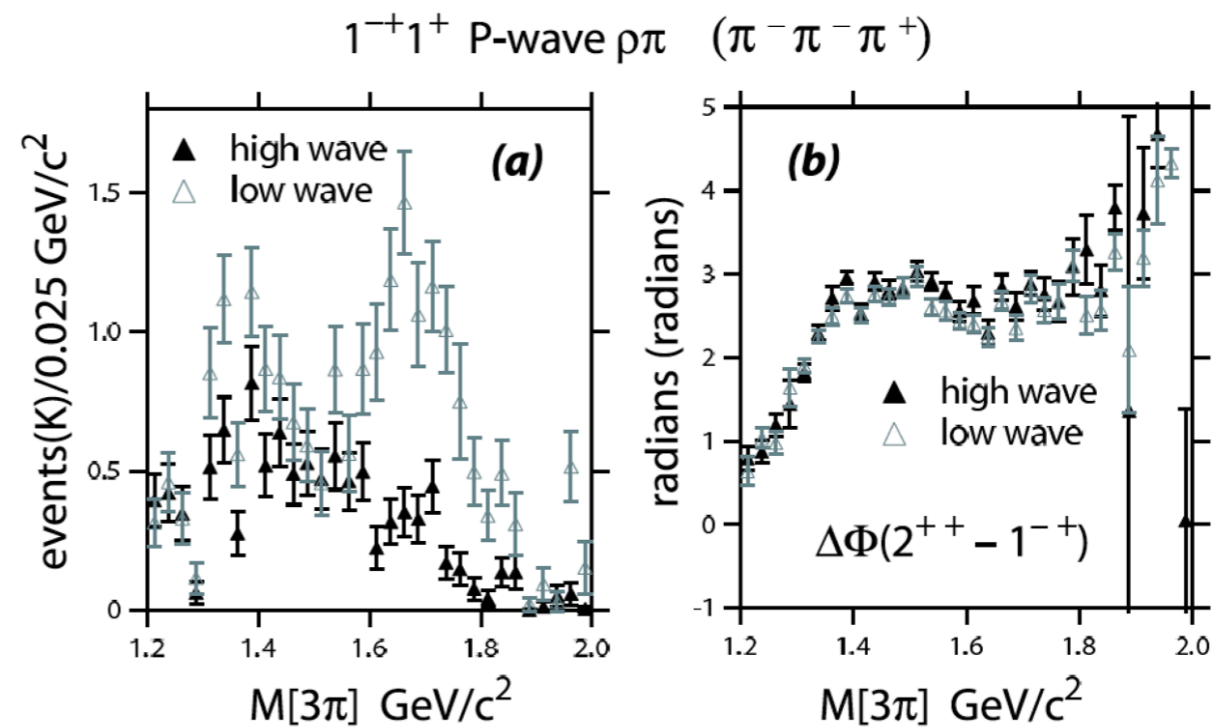

* **Not** observed in $\gamma p \rightarrow n \pi^+\pi^-\pi^+$ at CLAS: charged vs neutral exchange?

Quantum number counting

Assuming Vector Dominance

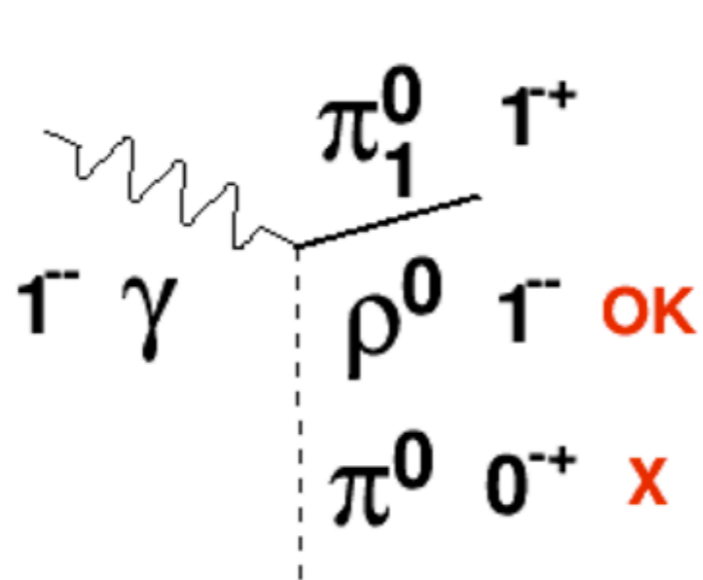
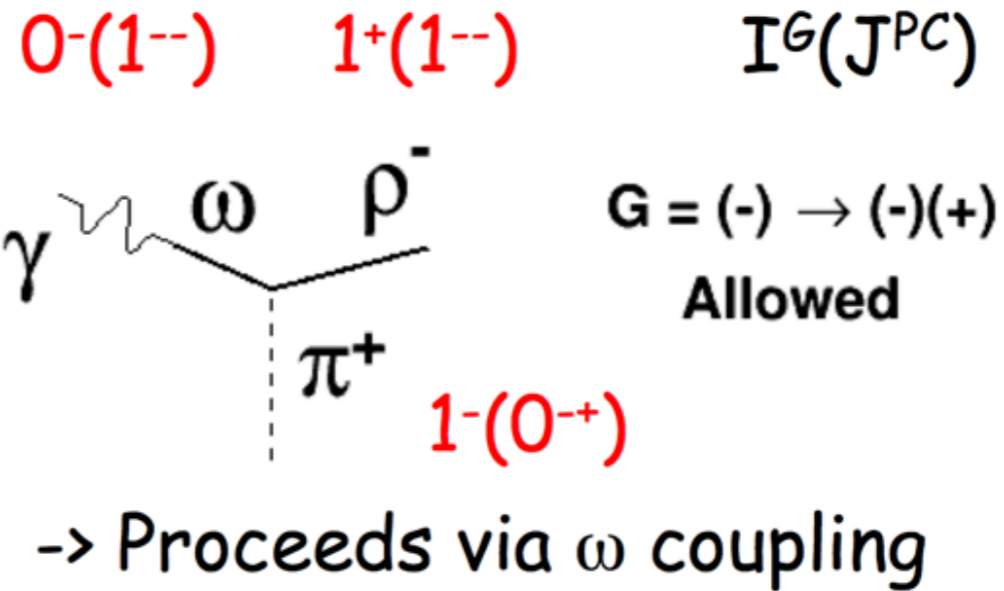
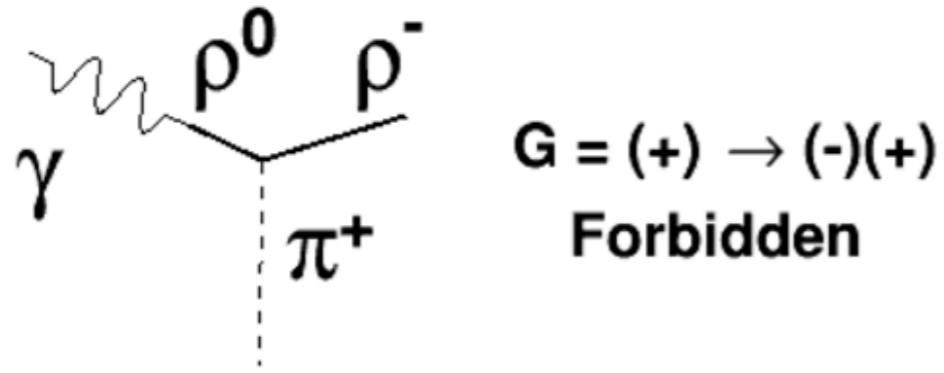

C Conservation

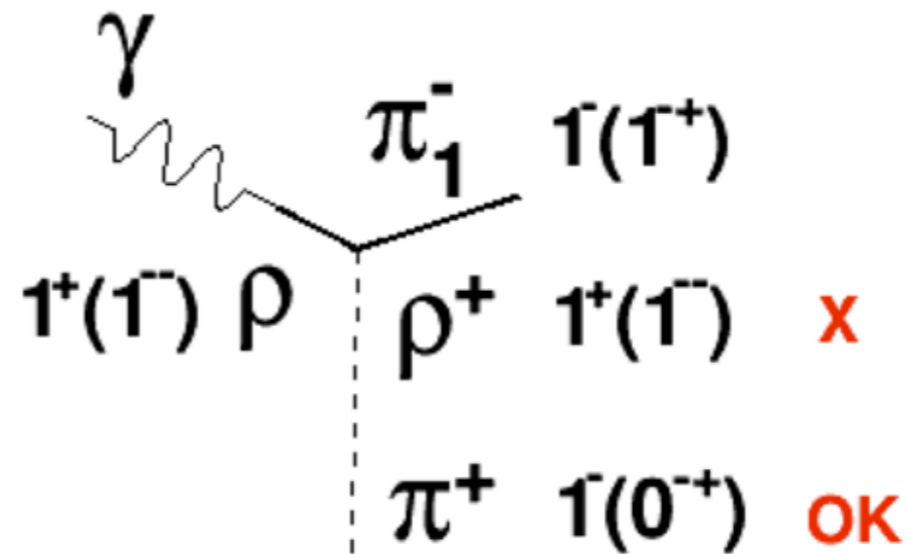

G-Parity Conservation