

# UNH Target Group Status and Goals

$b_1/A_{zz}$  Tensor Collaboration



Jefferson Lab  
2026-06-03

Karl J Slifer  
University of New Hampshire

# Polarized Target Group

---



Anchit Arora (PhD Student)

Eli Phippard (Undergrad)

Ben Limric (Undergrad)

Muhammad Farooq (PhD Student)

Chhetra Lama (PhD Student)

Utsav Shrestha (Post Doc)

Sam Takwira (Masters)

Aden Whitney (PhD Student)

Elena Long

Nathaly Santiesteban

Karl Slifer



## Dynamic Nuclear Polarization

Temp = 1 Kelvin

Field = 5 Tesla

140 GHz microwaves

Vector polarization of proton

Tensor Polarization of deuteron

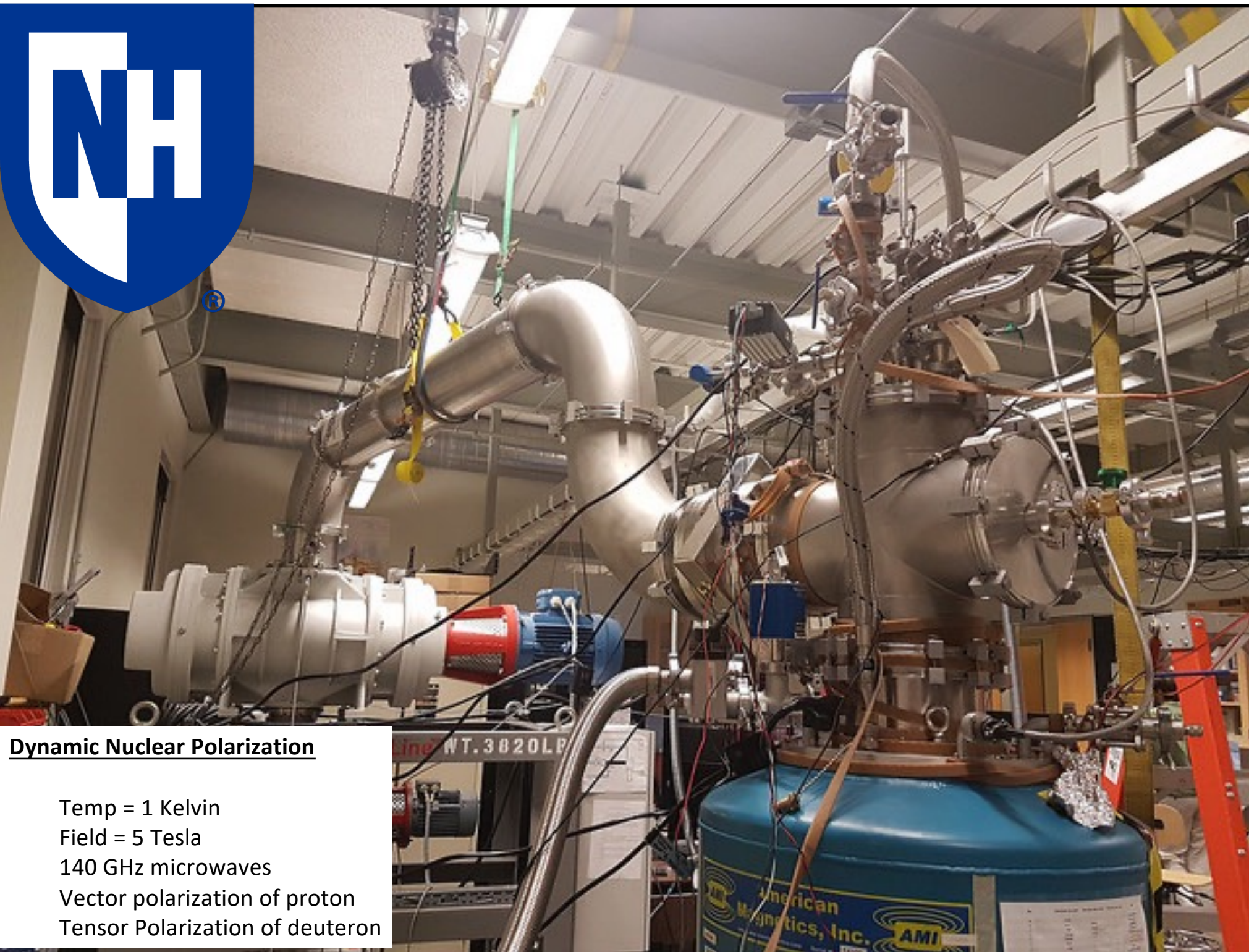

# Helium Recovery System

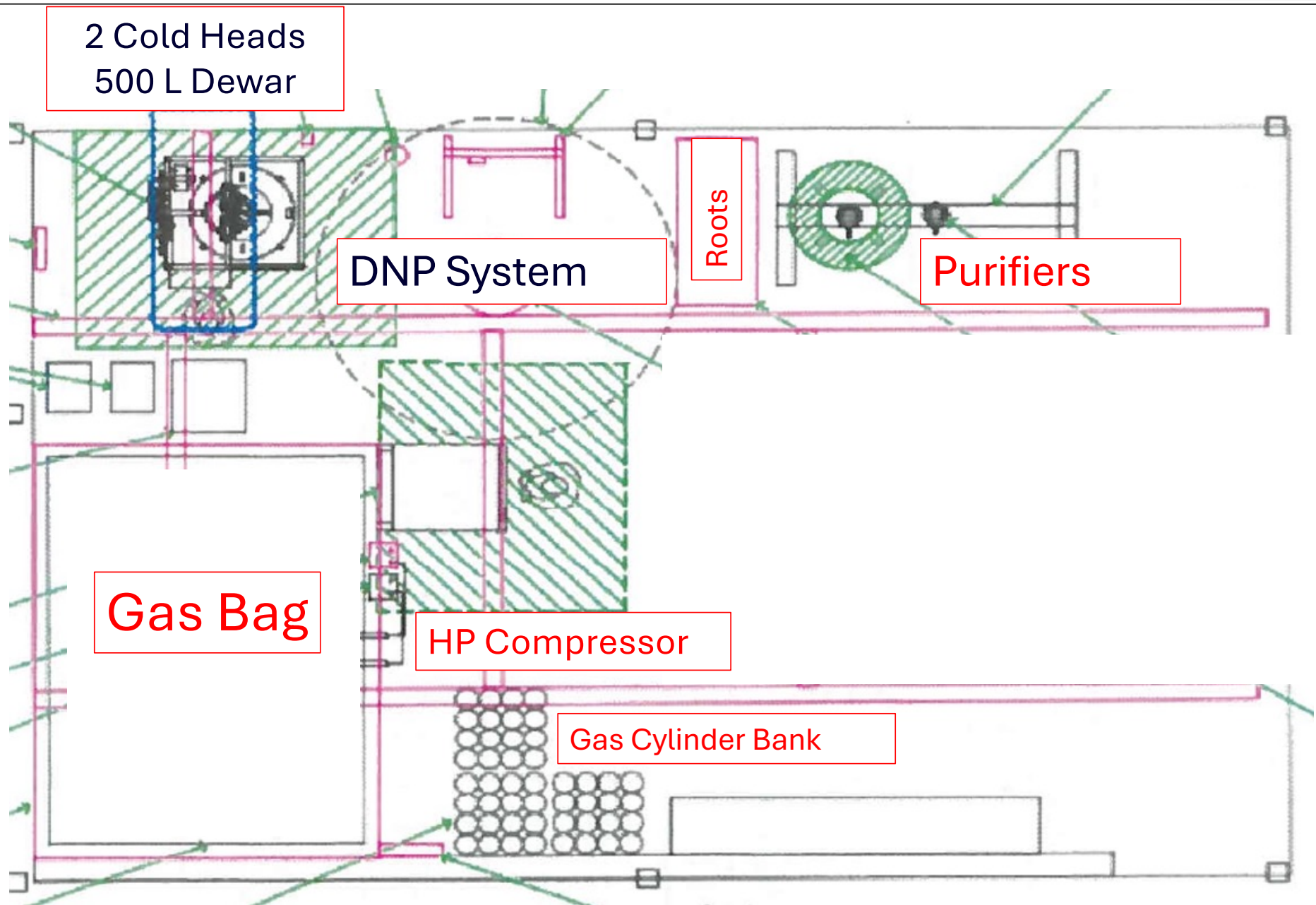

# Helium Recovery System



HP Gas cylinders

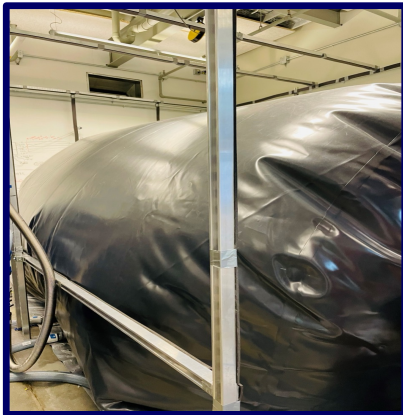

Gas Bag



Helium Purifier (dual )



Cold Heads  
500 L Mother Dewar

# Helium Recovery System Status

---

Rate: 40 L/day (average), 30-50L/day (variable)

Recapture efficiency : >90%

Liquid Capacity: 500-800 Liquid Liters Storage

Gas Capacity: 580 Liquid Liters Equivalent in 48 HP cylinders

Duty cycle: 5 days of physics followed by 3 weeks of recovery

# New Cooling Unit

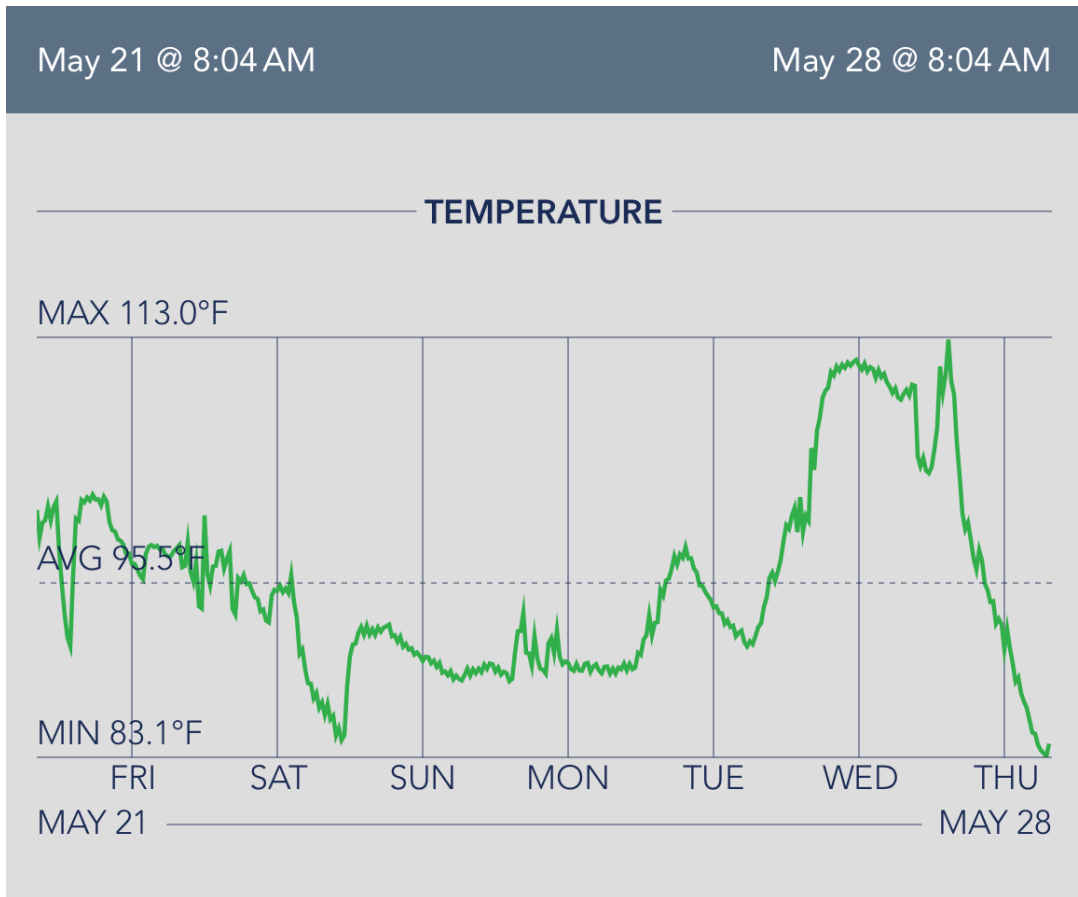

**Installed Monday!**

ANALYSIS OF THE COMPLEX NMR LINESHAPE OF POLARIZED  
DEUTERONS

BY

MICHAEL J. J. P. MCCLELLAN

BS, Central Connecticut State University, 2012

MS, Christopher Newport University, 2017

DISSERTATION

Submitted to the University of New Hampshire  
in Partial Fulfillment of  
the Requirements for the Degree of

Doctor of Philosophy

In

Physics

May, 2026

# Irradiated D-Butanol Complex NMR Signal

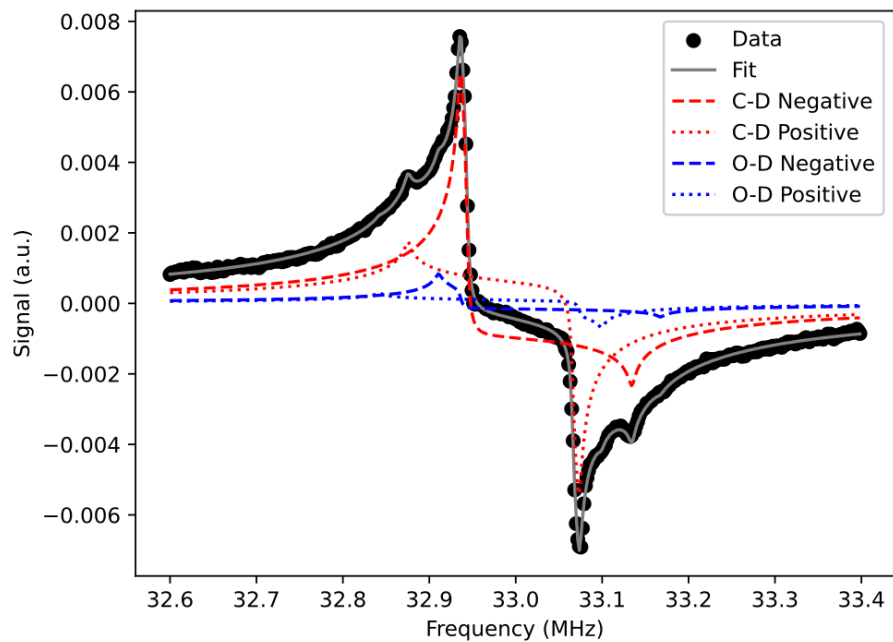

Aug. 29, 2024  
Theta=-87 deg

P= -16.9%

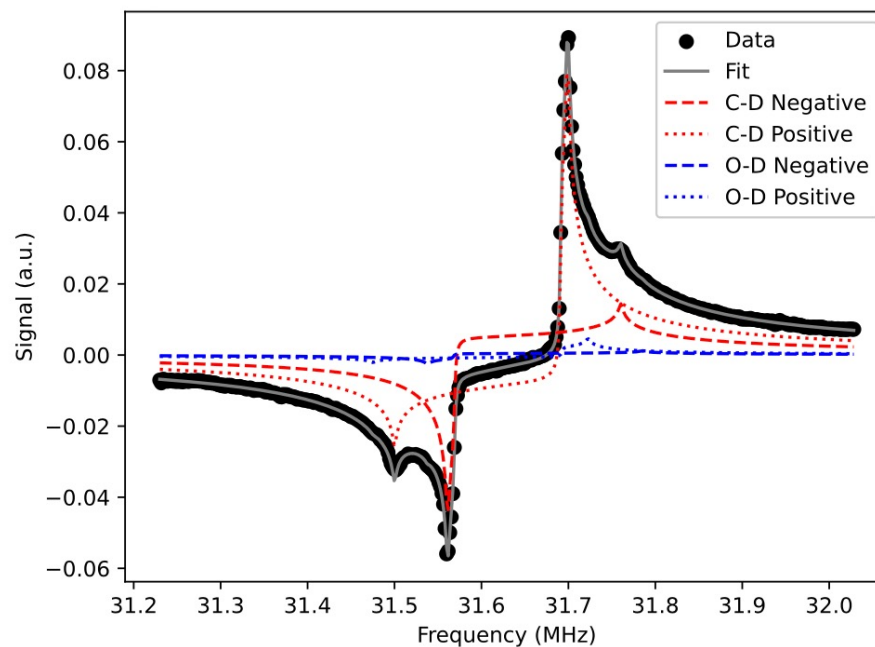

Aug. 29, 2024  
Theta=-88.5 deg

P= +36.8%

# Irradiated D-Butanol

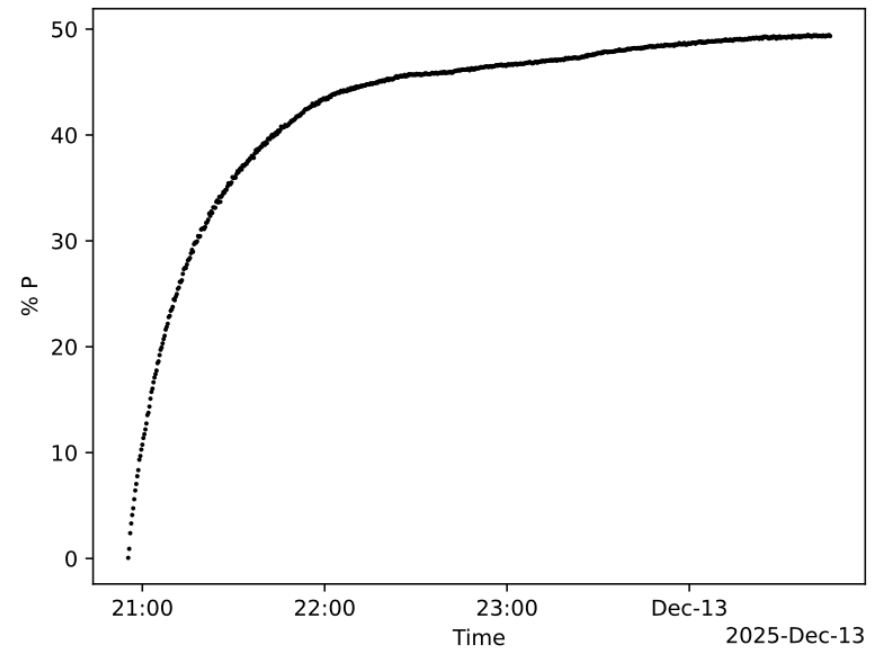
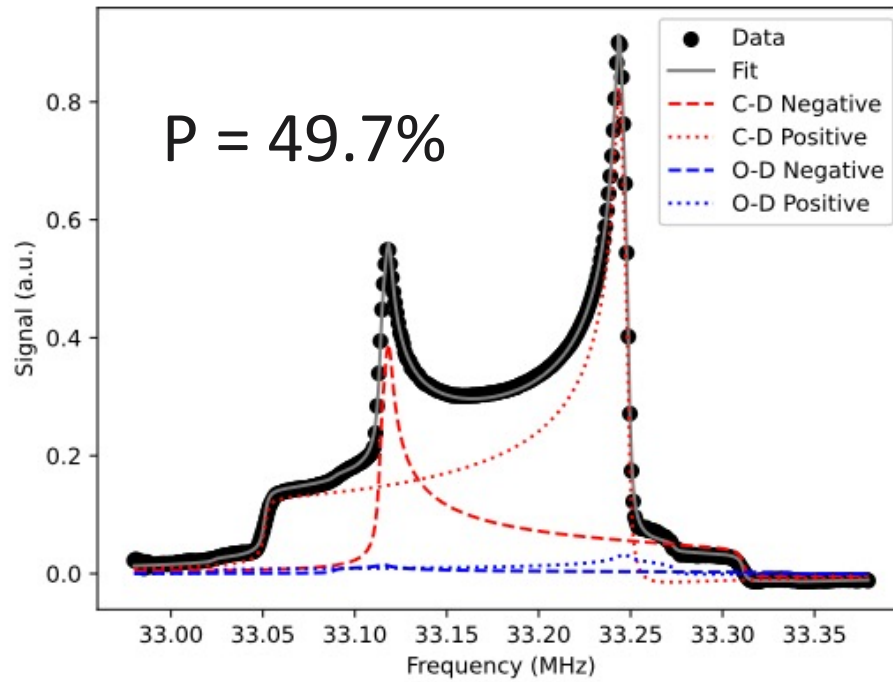

Dec. 13, 2025

B=5.077T  
142.2731 GHz

# Irradiated D-Butanol T.E.

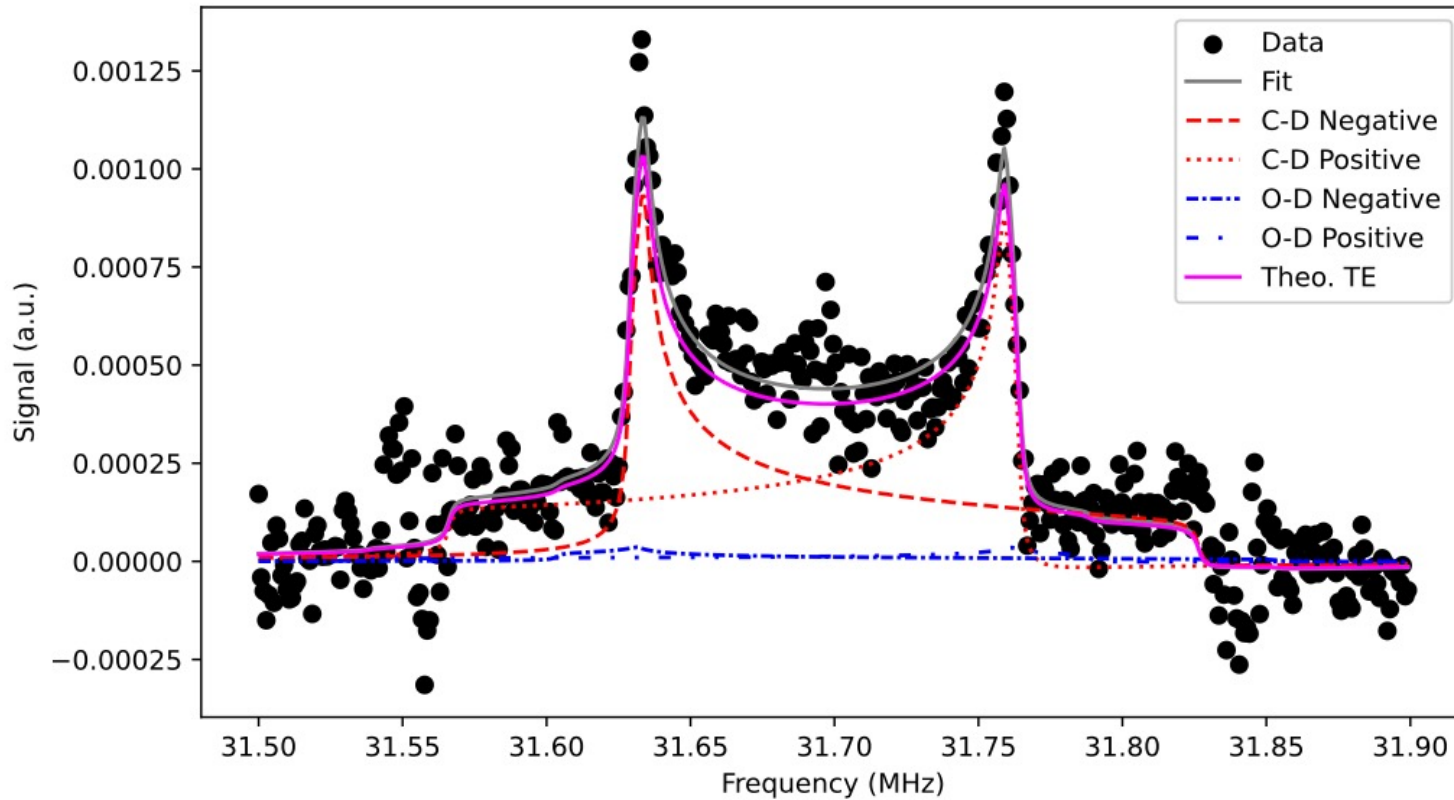

Dec. 15, 2025

4.850 T  
1.67 K  
P=0.061%

# Irradiated D-Butanol

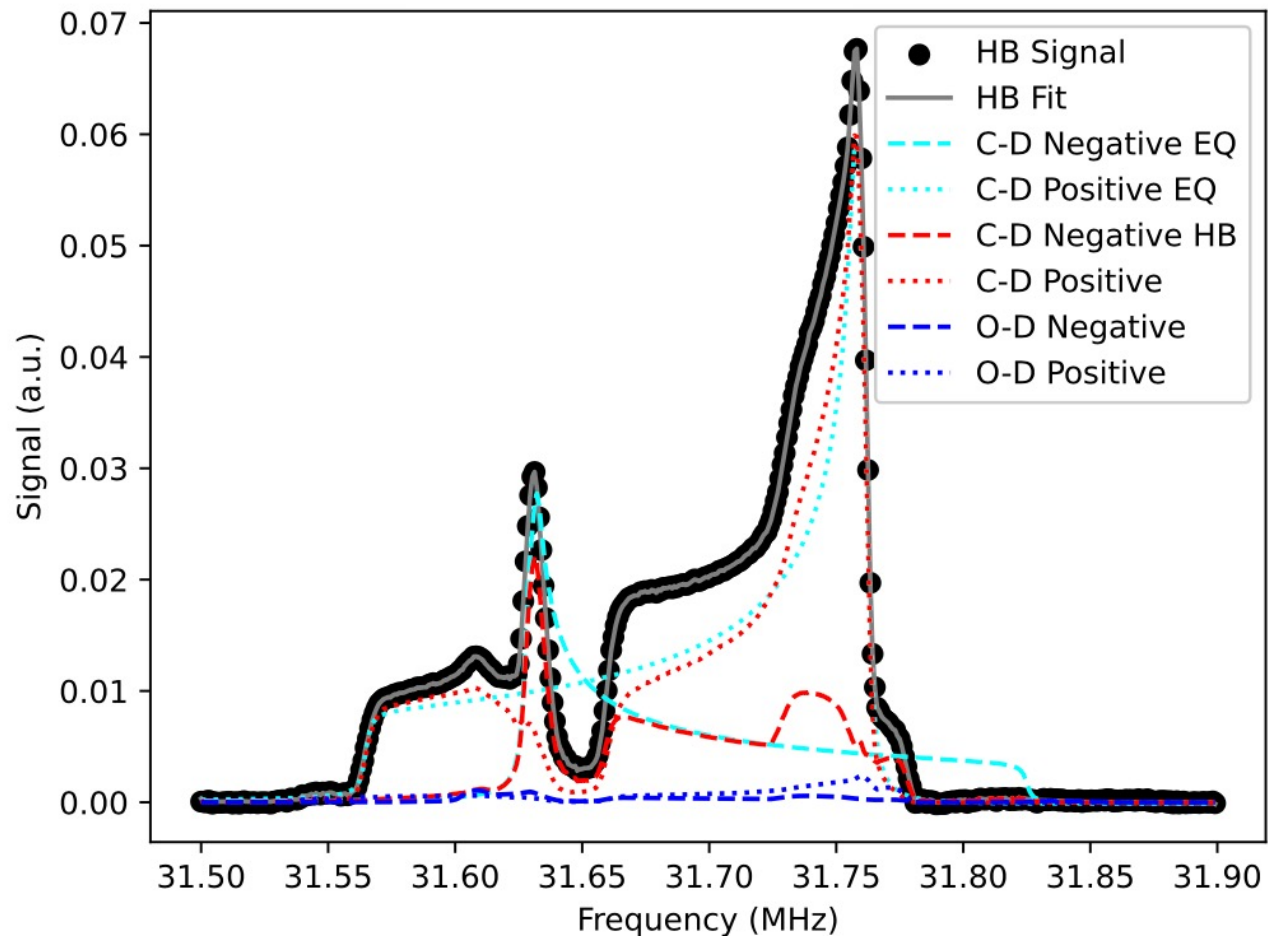

Dec 16, 2025

P=43%

Q=19%

# Irradiated D-Butanol

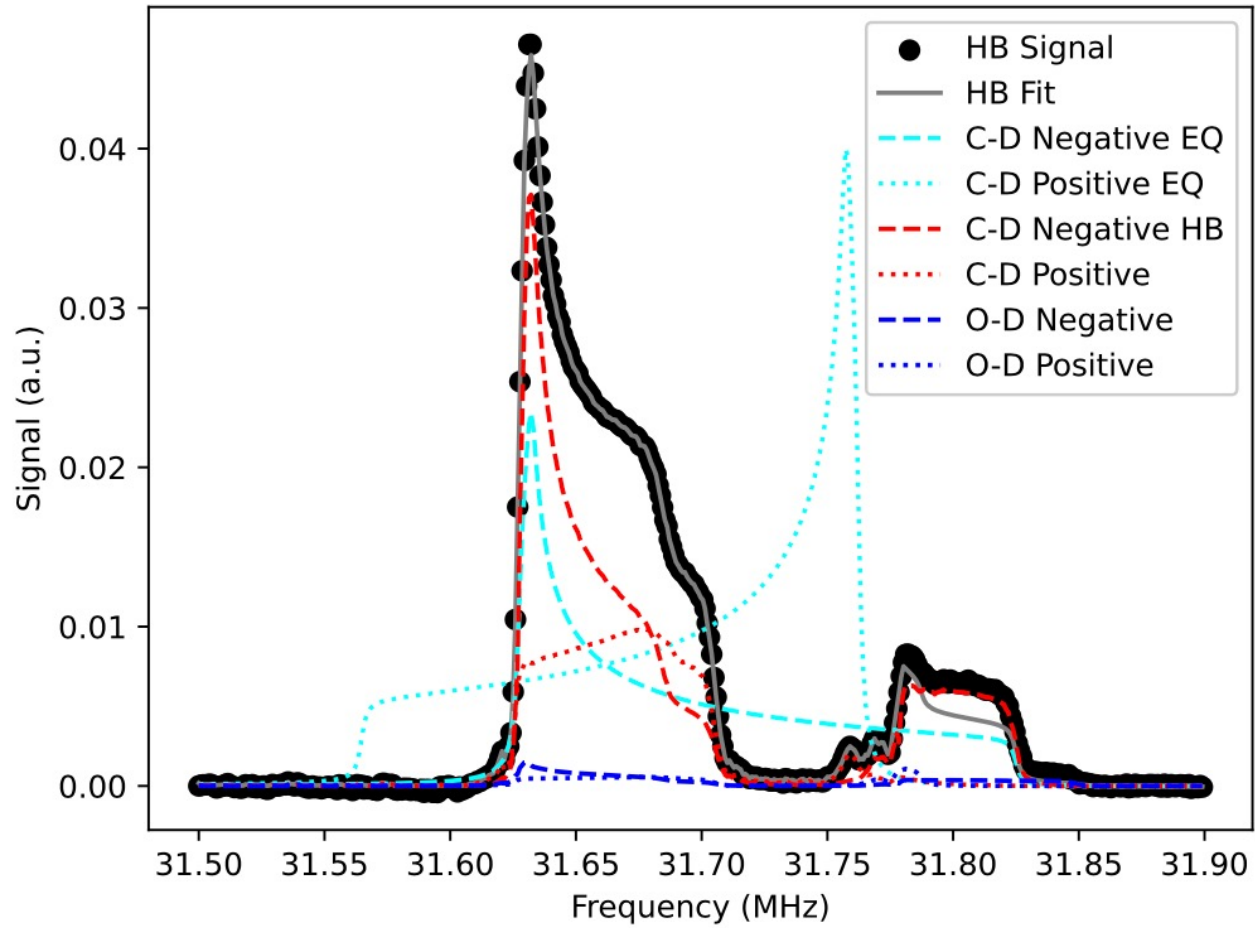

Dec 16, 2025

P = 22.5%

Q = -6.8%

# New Target Ladder

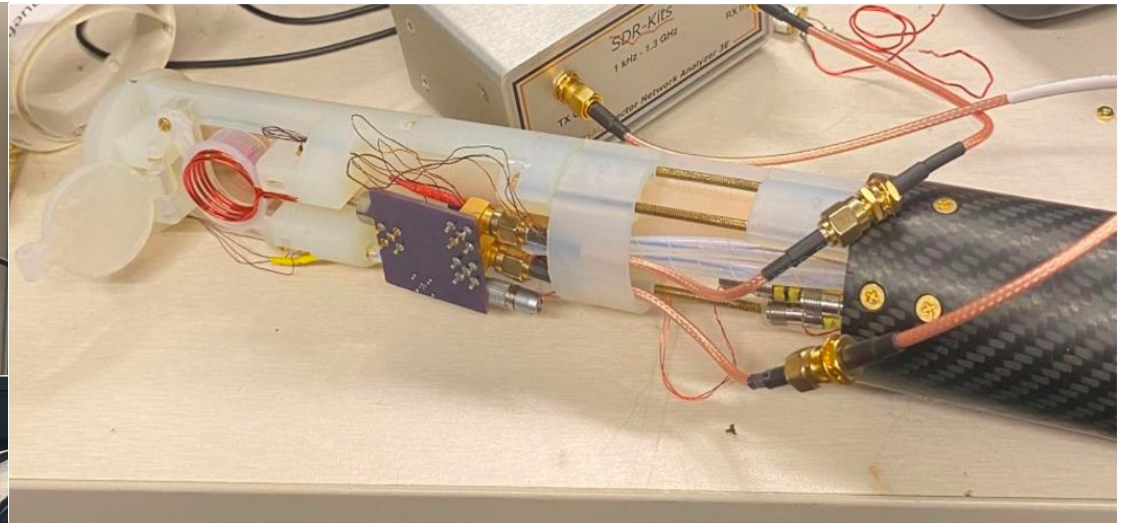
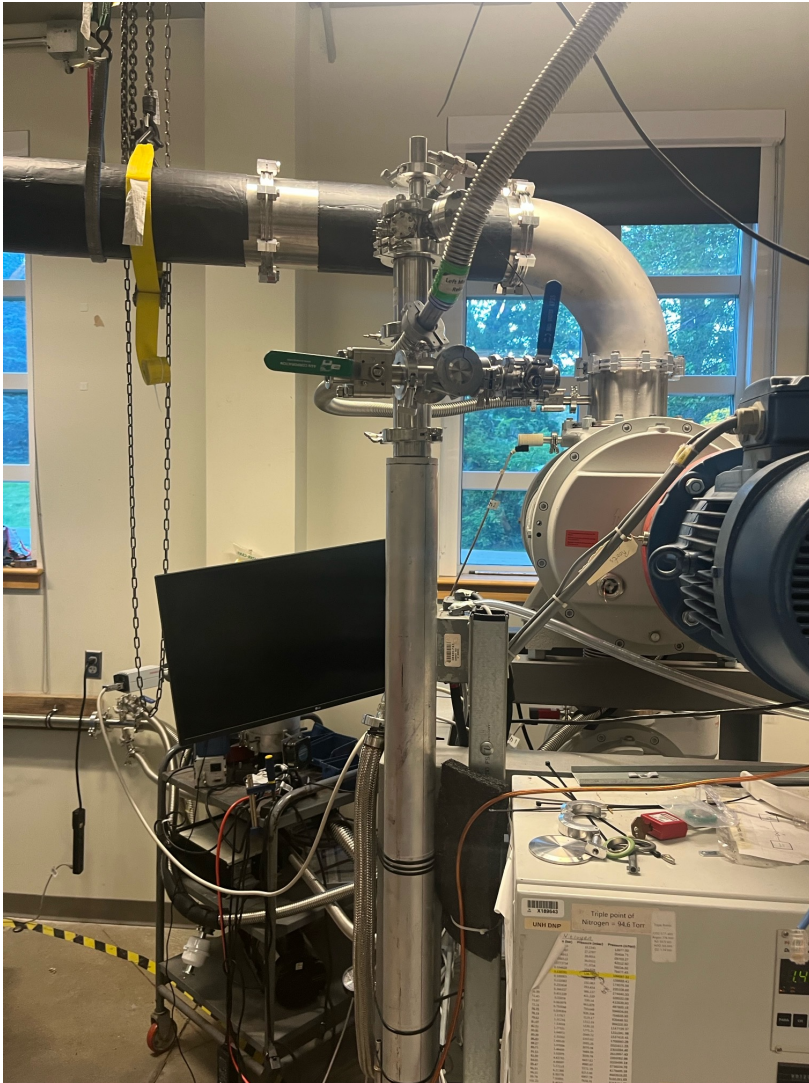

Plan to create multiple target sticks  
to avoid any more long delays from breakage

See Anchit's talk

# New SSRF Circuit

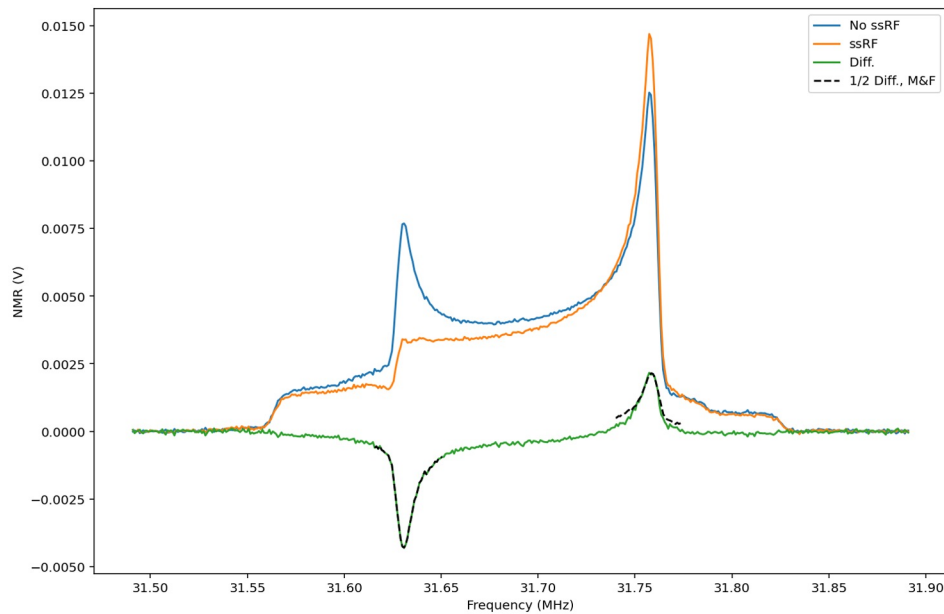

Some indication that we have been "over-burning".

New coils to improve SSRF coil uniformity

New tuning to improve VSWR

New timing circuit to optimize the time spent burning the peak and shoulder

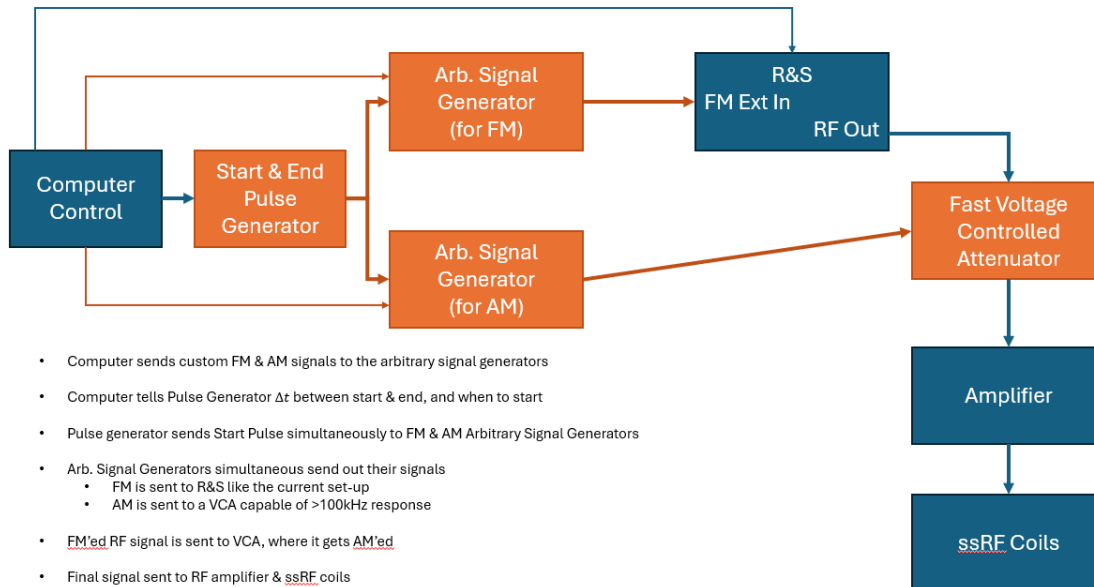

- Computer sends custom FM & AM signals to the arbitrary signal generators
- Computer tells Pulse Generator  $\Delta t$  between start & end, and when to start
- Pulse generator sends Start Pulse simultaneously to FM & AM Arbitrary Signal Generators
- Arb. Signal Generators simultaneous send out their signals
  - FM is sent to R&S like the current set-up
  - AM is sent to a VCA capable of >100kHz response
- FMed RF signal is sent to VCA, where it gets AMed
- Final signal sent to RF amplifier & ssRF coils
- Pulse generator sends End Pulse to FM & AM Sig Gens, setting FM outside NMR window and setting AM to Amplitude = 0

See Farooq's talk

# Target Material Production

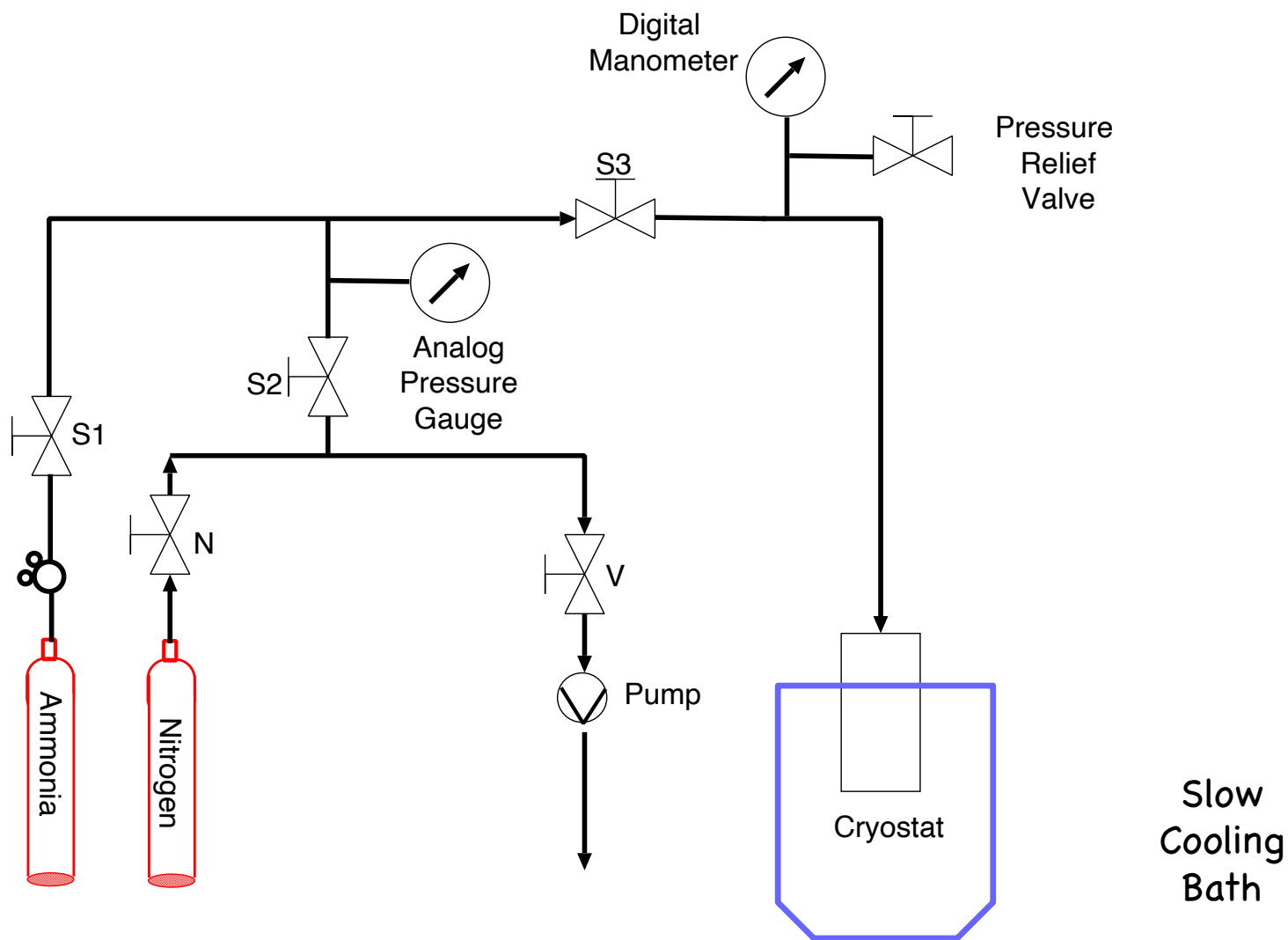



# Target Material Production

---



Quantitative study of Flash Freezing vs Slow Cooling

**Eli Phippard Undergrad Thesis**

May 2026





# Beam Irradiation Preparations

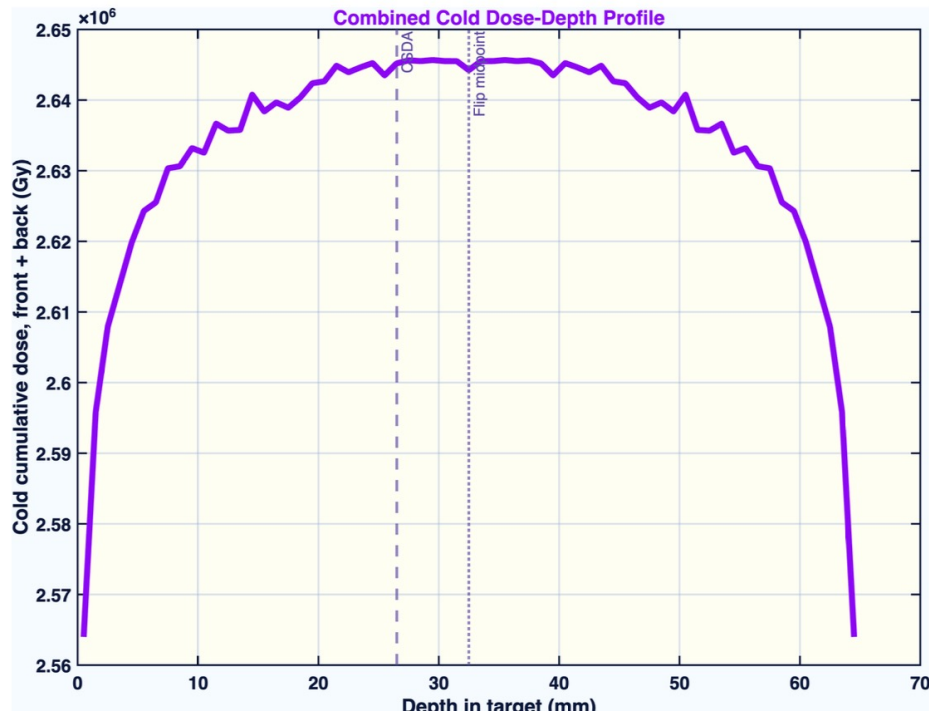

Samuel Takwira

Topas Monte Carlo Simulations

8 MeV irradiations of ND3

See Elena Long's talk

Approved BeamNet Proposal  
To irradiate ND3 at Jlab in the UITF  
Fall 2026

# Summary

## Helium Recapture System

Generating more heat than our lab can dissipate  
New Air Handler Installed  
In-situ Chiller being replaced with Building Water

## Target Sticks

Building redundancy to avoid further delays  
Goal is to have at least two sticks working this summer.

## DNP and ssRF Results

We've hit max expected polarization in d-Butanol

HB spectrum looks ideal.

But we've using too much power on SSRf burns  
kills polarization. New SSRF control software.

Demonstrated small amount of negative tensor polarization

## Material Production

Reliable method to slow cool creates higher quality material  
BeamNetUS approval for irradiations in Fall 2026