

# Overview of SoLID Physics Program

Hall A/C Collaboration Meeting, June 17-18, 2026

Vladimir Khachatryan  
Mississippi State University

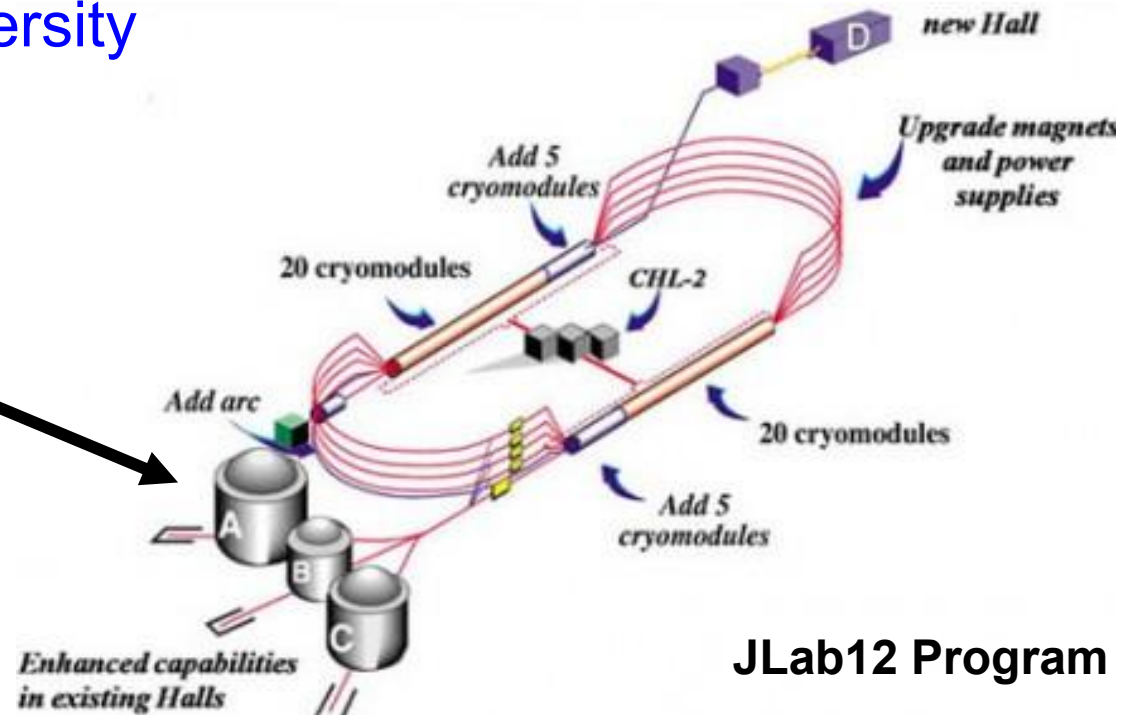
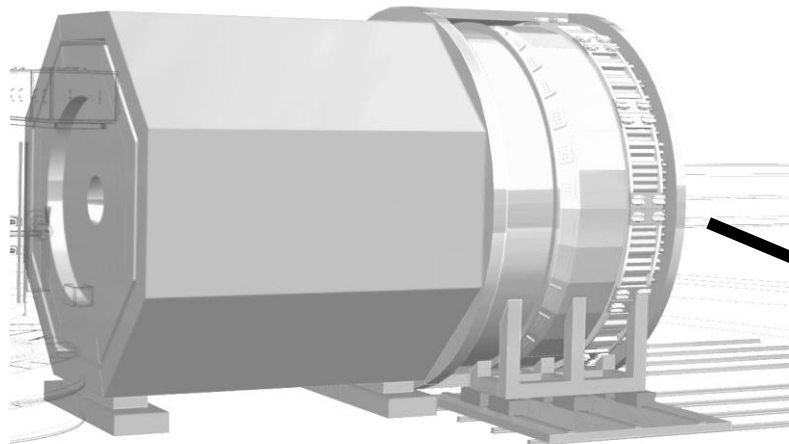

JLab12 Program



Acknowledgement: Thanks to Jian-Ping Chen, Haiyan Gao, Zein-Eddine Meziani, Paul Souder, Xiaochao Zheng, Ye Tian, Henry Klest, Zhiwen Zhao, Garth Huber, Bill Li, Michael Nycz, Eric Fuchey, and many other SoLID collaborators.

## 1. Introduction

## 2. SoLID Physics Program

### i) Semi-inclusive DIS (SIDIS)

→ Transverse Momentum Dependent Distributions (TMDs)

→ Single-spin Asymmetries (SSAs)

### ii) Generalized Parton Distributions (GPDs)

→ Double Deeply Virtual Compton Scattering (DDVCS)

### iii) Parity Violating DIS (PVDIS)

→ Standard Model Precision Test

### iv) Threshold $J/\psi$ Production

→ Gluon Field, Proton Mass and Mass Radius

## 3. Two new ideas

i) Strangeness D-term potential studies with SoLID

ii) L/T separation potential studies with SoLID

## 4. Summary

# Introduction

SoLID will *maximize* the science return of the 12-GeV CEBAF upgrade by **combining...**

## High Luminosity

$10^{37-39} / \text{cm}^2/\text{s}$   
[ >100x CLAS12 ] [ >1000x EIC ]



## Large Acceptance

Full azimuthal  $\phi$  coverage

Research at **SoLID** will have a *unique* capability to **explore** the QCD landscape while **complementing** the research of other key facilities

- Pushing the phase space in the search of new physics and hadronic physics
- 3D momentum imaging of a relativistic strongly interacting confined system (nucleon spin)
- Superior sensitivity to the differential electro- and photo-production cross section of  $J/\psi$  near threshold (proton mass)

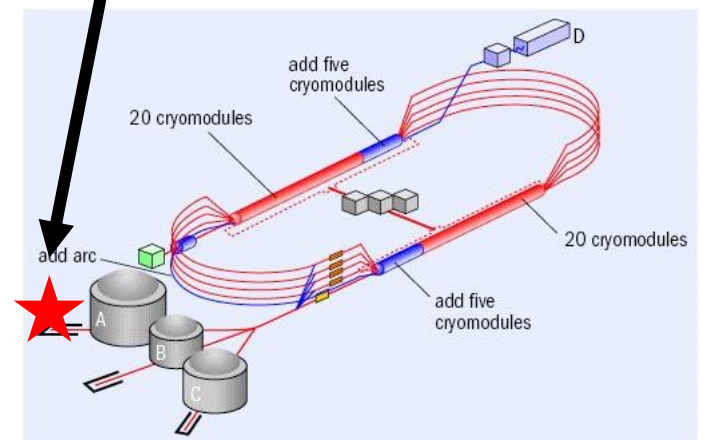
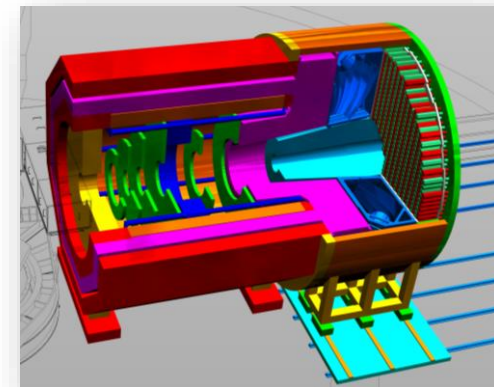

Synergizing with the pillars of EIC science (proton spin and mass) through high-luminosity valence quark tomography and precision  $J/\psi$  production near threshold

# Introduction: Approved SoLID Experiments

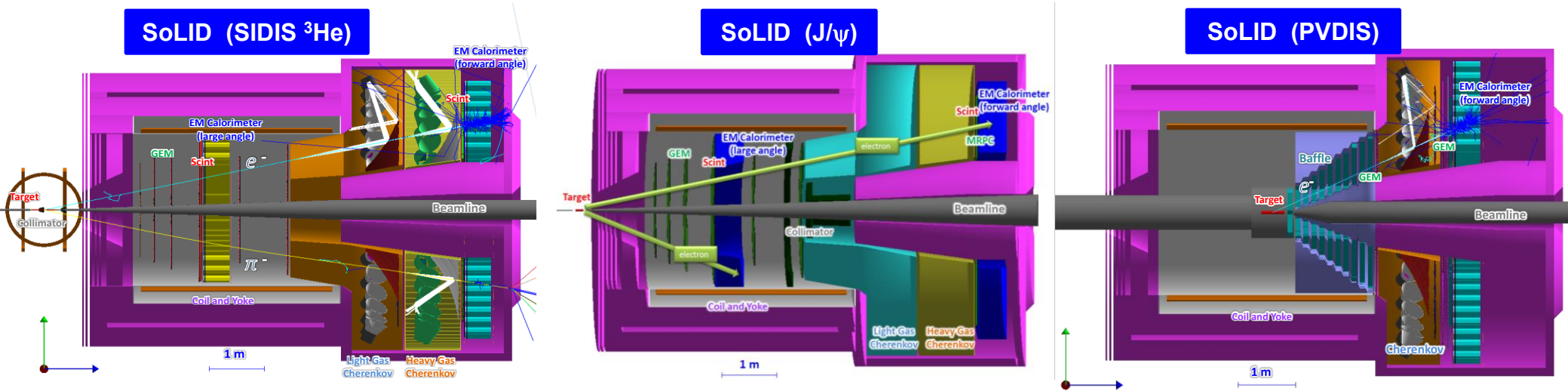















- A) SIDIS: (3) Rating A**
- Transversely Polarized  $^3\text{He}$  (n): Transversity, Sivers, Pretzelosity TMDs
  - Longitudinally Polarized  $^3\text{He}$  (n): Worm-gear TMDs
  - Transversely Polarized  $\text{NH}_3$  (p): Transversity, Sivers, Pretzelosity TMDs
- B) Threshold  $J/\psi$ : Rating A**
- Gluon Field, Proton Mass, Mass Radius
- C) Parity: PVDIS: Rating A**
- Beam Normal SSA Rating A-
  - PVEMC Conditional Approval
  - Standard Model Test & Nucleon Structure
  - Two-photon Effects
  - Isospin EMC Effects
- D) DDVCS: Rating A (C1 Conditional)**
- GPDs
- E) Run group experiments (8): approved for GPDs, TMDs, and Spin**

# SIDIS: TMDs – confined motion inside the nucleon

## Leading twist: 8 TMDs

→ Nucleon Spin  
 → Quark Spin

		Quark polarization		
		Un-Polarized	Longitudinally Polarized	Transversely Polarized
Nucleon Polarization	U	$f_1 =$ 		$h_1^\perp =$  -  <b>Boer-Mulder</b>
	L		$g_1 =$  -  <b>Helicity</b>	$h_{1L}^\perp =$  - 
	T	$f_{1T}^\perp =$  -  <b>Sivers</b>	$g_{1T}^\perp =$  - 	$h_{1T} =$  -  <b>Transversity</b> $h_{1T}^\perp =$  -  <b>Pretzelosity</b>

Leading twist refers to leading power in cross-section expansion

# SIDIS: TMDs – confined motion inside the nucleon

## Transversity

### Transversely Polarized Nucleon TMDs

- Nucleon Spin
- Quark Spin

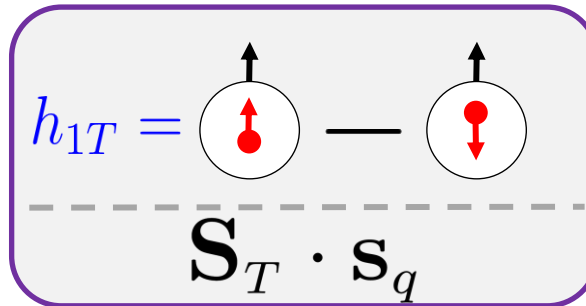

### Relevant Vectors

- $\mathbf{S}_T$ : Nucleon Spin
- $\mathbf{s}_q$ : Quark Spin
- $\mathbf{k}_\perp$ : Quark Transverse Momentum
- $\mathbf{P}$ : Virtual photon 3-momentum (defines z-direction)

- $h_{1T} (h_1) = g_1$  (no relativity)
- $h_{1T} \rightarrow$  tensor charge (lattice QCD calculations)
- Connected to nucleon beta decay and EDM

## Sivers

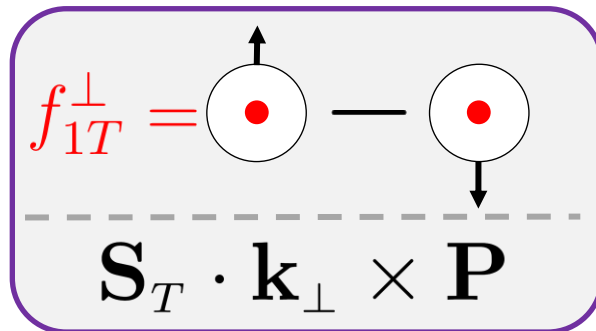

- Nucleon spin - quark orbital angular momentum (OAM) correlation  
– zero if no OAM (model dependence)

## Pretzelosity

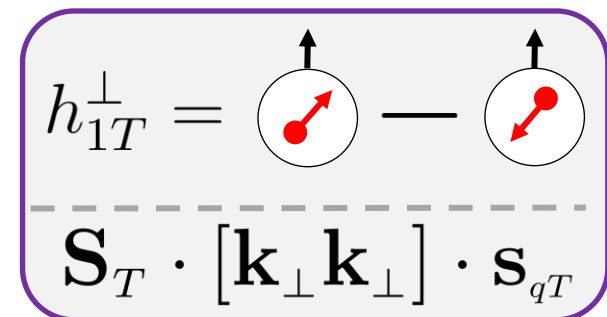

- Interference between components with OAM difference of 2 units (i.e., s-d, p-p) (model dependence)
- Signature for relativistic effect

# SIDIS: SSAs – separation of the spin asymmetries

SIDIS SSAs depend on 4-D variables  
 (x, Q<sup>2</sup>, z, P<sub>T</sub>) and small asymmetries demand  
**large acceptance + high luminosity** allowing for  
 measuring symmetries in 4-D binning with precision!

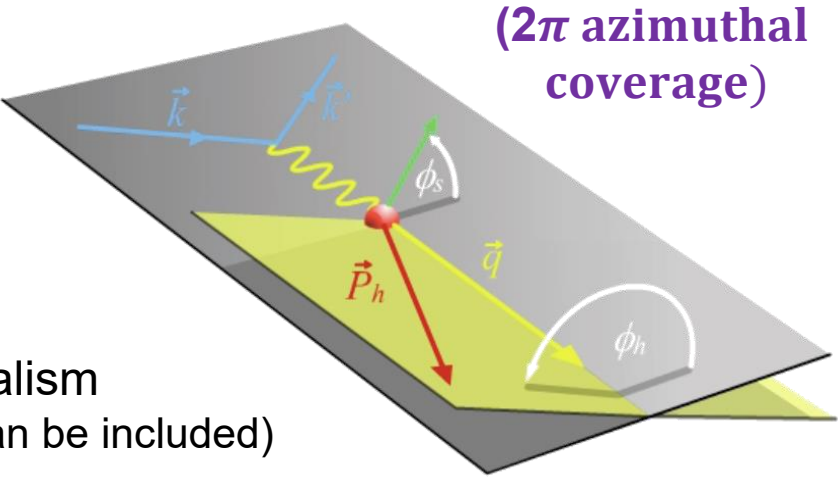

$$A_{UT}(\phi_h, \phi_S) = \frac{1}{P_{t,pol}} \frac{N^\uparrow - N^\downarrow}{N^\uparrow + N^\downarrow}$$

Leading twist formalism  
 (higher-twist terms can be included)

$$= \underbrace{A_{UT}^{Collins}}_{\text{purple}} \sin(\phi_h + \phi_S) + \underbrace{A_{UT}^{Pretzelosity}}_{\text{blue}} \sin(3\phi_h - \phi_S) + \underbrace{A_{UT}^{Sivers}}_{\text{green}} \sin(\phi_h - \phi_S)$$

$$A_{UT}^{Collins} \propto \langle \sin(\phi_h + \phi_S) \rangle_{UT} \propto h_1 \otimes H_1^\perp$$

Collins fragmentation function from e<sup>+</sup>e<sup>-</sup> collisions

$$A_{UT}^{Pretzelosity} \propto \langle \sin(3\phi_h - \phi_S) \rangle_{UT} \propto h_{1T}^\perp \otimes H_1^\perp$$

$$A_{UT}^{Sivers} \propto \langle \sin(\phi_h - \phi_S) \rangle_{UT} \propto f_{1T}^\perp \otimes D_1$$

Unpolarized fragmentation function

# SIDIS: SSAs – precision mapping in multi-dimension

SoLID-SIDIS program: Large acceptance, Full azimuthal coverage + High luminosity

- 4-D mapping of asymmetries with precision
- Constrain models and forms of TMDs, Tensor charge, ...
- Lattice QCD, QCD dynamics

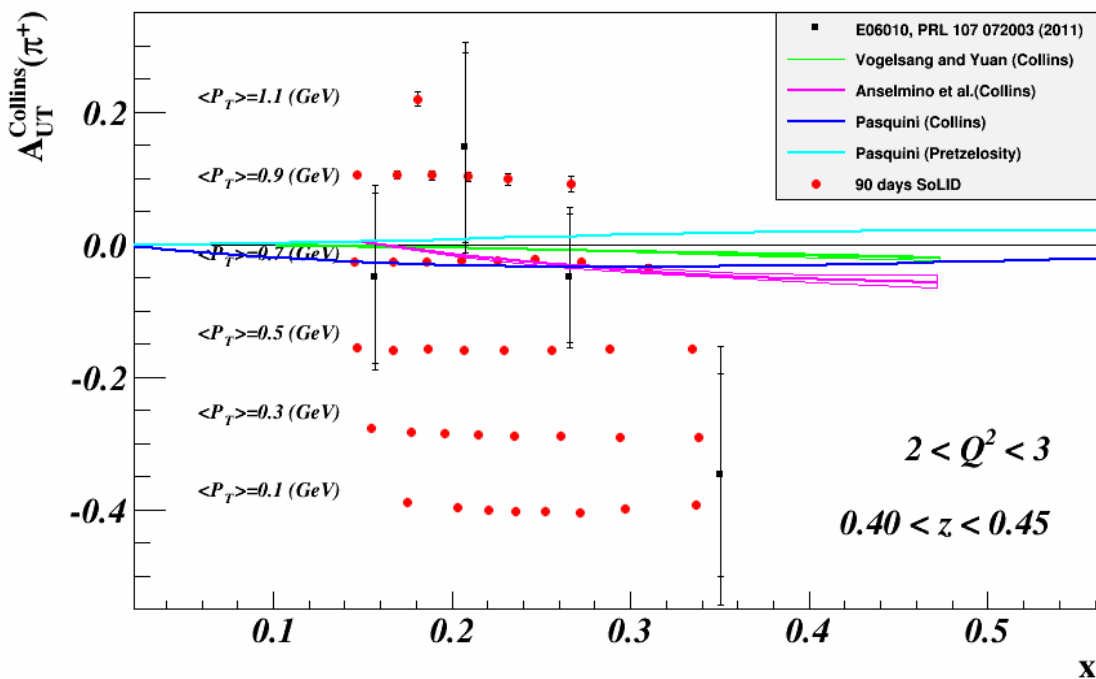

More than 1400 bins in  $x$ ,  $Q^2$ ,  $z$ , and  $P_T$  for 11/8.8 GeV beam

## Transversity

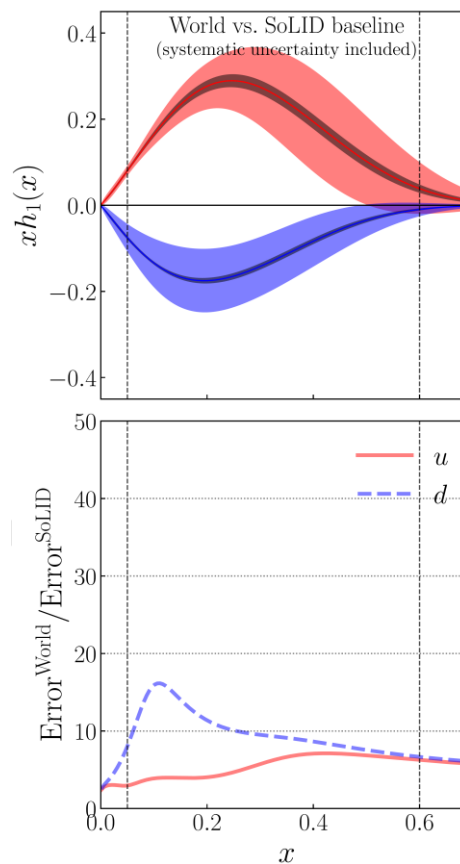

## Sivers

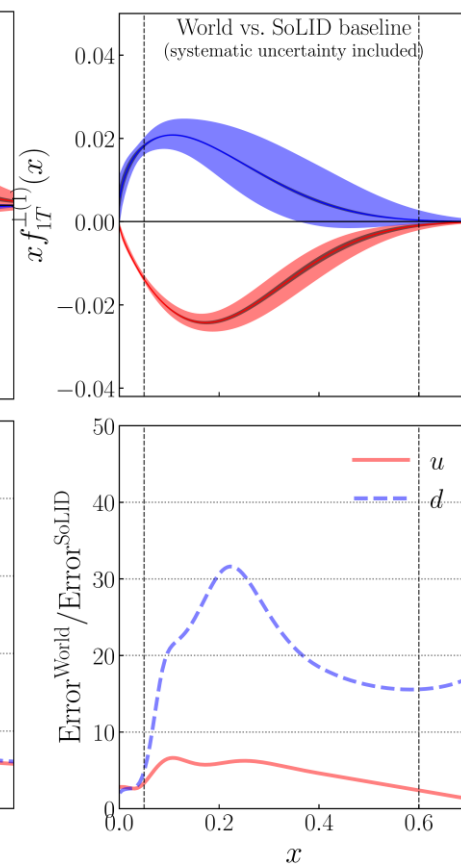

# SIDIS: SSAs – impact on tensor charge

## Definition

$$\langle P, S | \bar{\psi}_q i\sigma^{\mu\nu} \psi_q | P, S \rangle = g_T^q \bar{u}(P, S) i\sigma^{\mu\nu} u(P, S) \quad g_T^q = \int_0^1 [h_1^q(x) - h_{\bar{1}}^q(x)] dx$$

- A fundamental QCD quantity: matrix element of local operators
- Moment of transversity distribution
- Valence quark dominant
- Precision calculations available from lattice QCD
- Probe new physics combined with EDMs

$$d_n = g_T^d d_u + g_T^u d_d + g_T^s d_s$$

**SoLID Projection**

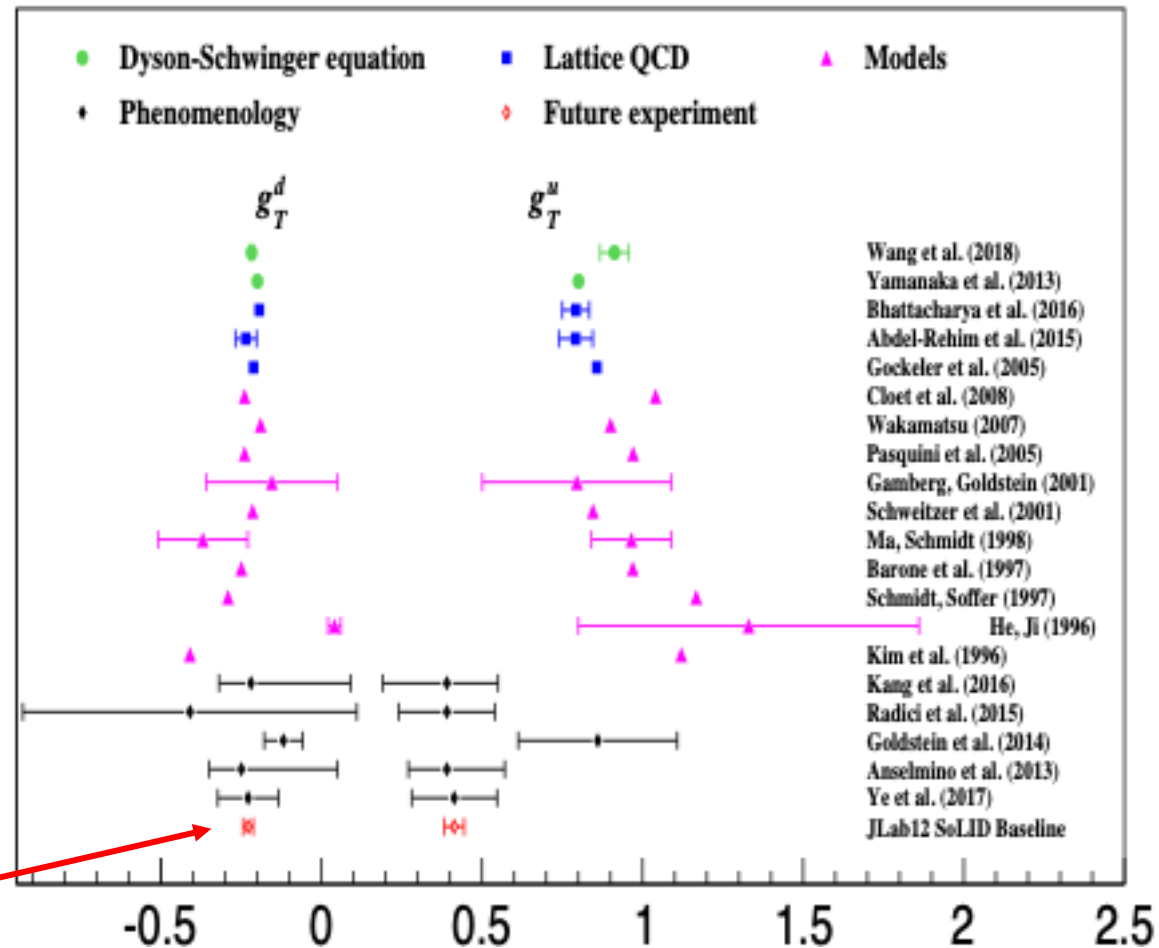

# GPD: DDVCS and more

- DDVCS with SoLID $\mu$  (SoLID+muon detector): C1 approval with **Rating A**  
(another DDVCS proposal with  $\mu$ CLAS12: C1 approved with **Rating A**)
- Deep Exclusive Meson Production: approved run-group experiment
- TCS (Time-like Compton Scattering): approved run-group experiment

## Double Deeply Virtual Compton Scattering (PR12-25-010)

- C1 Conditionally approved with A rating
- First ever DDVCS to access the full kinematic space for extracting GPDs
- A breakthrough physics program (from PAC53 closeout)

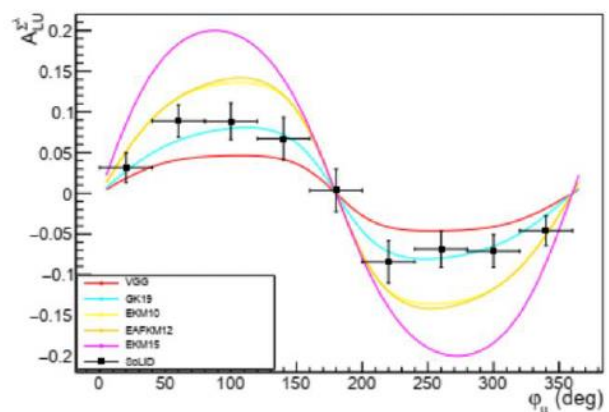

DVCS-like region

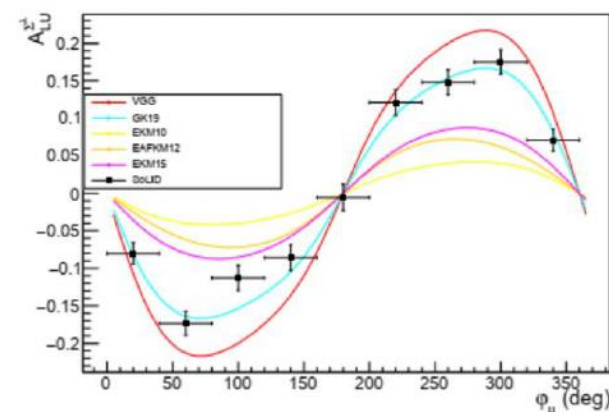

TCS-like region

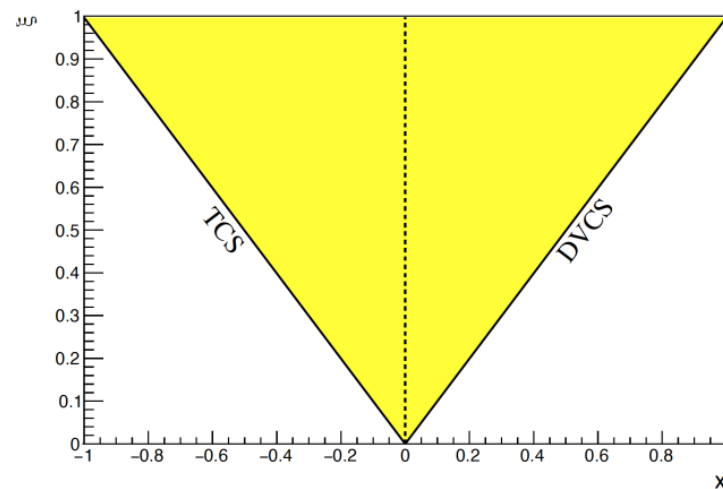
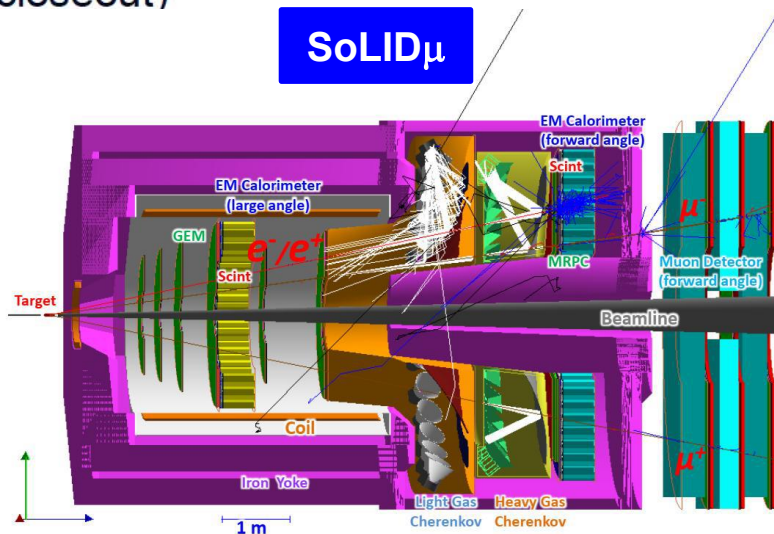

# PVDIS: Standard Model Precision Test

12 GeV CEBAF program:  
Extraordinary opportunity to do the ultimate PVDIS measurement

Strategy: sub-1% precision over broad kinematic range

sensitive Standard Model test

detailed study of hadronic structure contributions

SoLID (PVDIS)

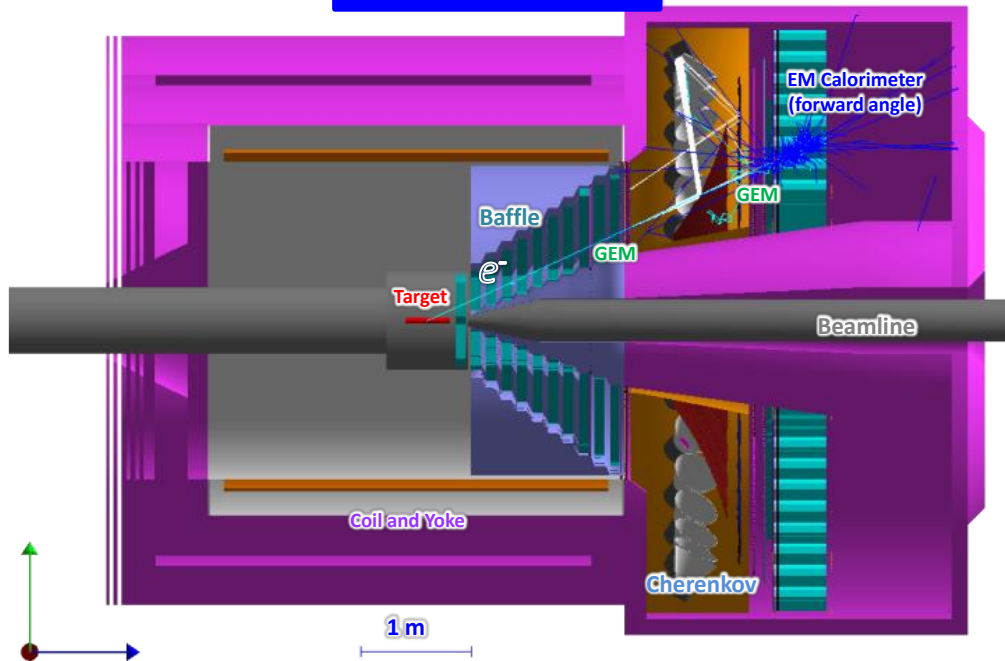

PVDIS Asymmetry Uncertainty (%)

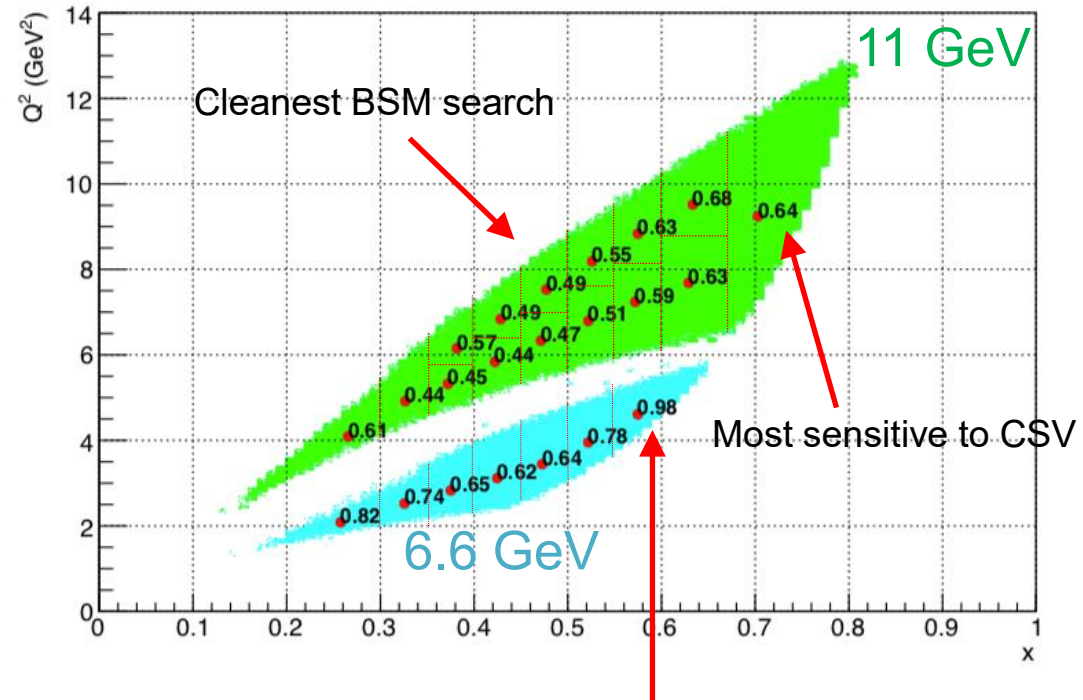

Most sensitive to HT

# PVDIS: Standard Model Precision Test

SoLID makes a unique contribution to the SMEFT program

Improvement in couplings

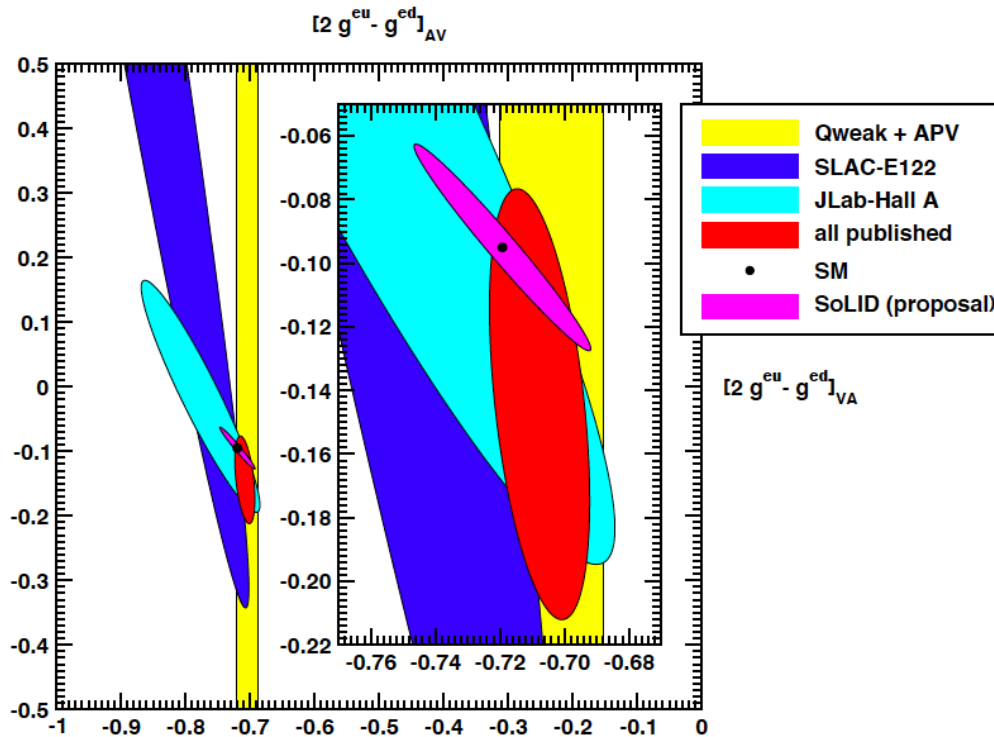

Improvement in energy reach for electron-nucleon couplings

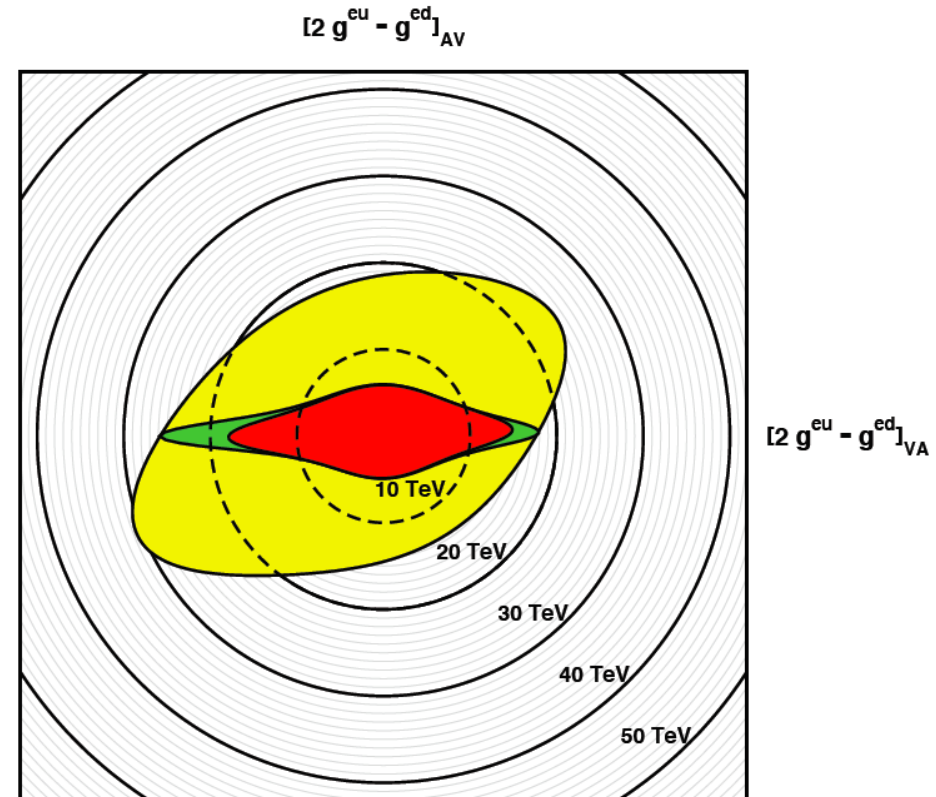

Unique sensitivity to

- lepto-phobic  $Z'$ , dark boson  $Z_d$

Also provides precision study of

- charge symmetry violation
- high-twist effects
- $d/u$  at high- $x$

- Published data
- Published data + P2
- Published data + P2 + SoLID

# PVDIS: Structure Function Ratio $d/u$ for the Proton

$$A_{PV} = \frac{G_F Q^2}{\sqrt{2} \pi \alpha} [a(x) + f(y)b(x)]$$

$$A_{PVDIS}^p(x) \approx \frac{u(x) + 0.91 d(x)}{u(x) + 0.25 d(x)}$$

PVDIS is complementary to the rest of the JLab  $d/u$  program

**PVDIS has no nuclear effects**

Additional observables provided by PVDIS (both p and d) can help determination of strangeness PDF

Phys. Rev. D 87 (2013) 094012

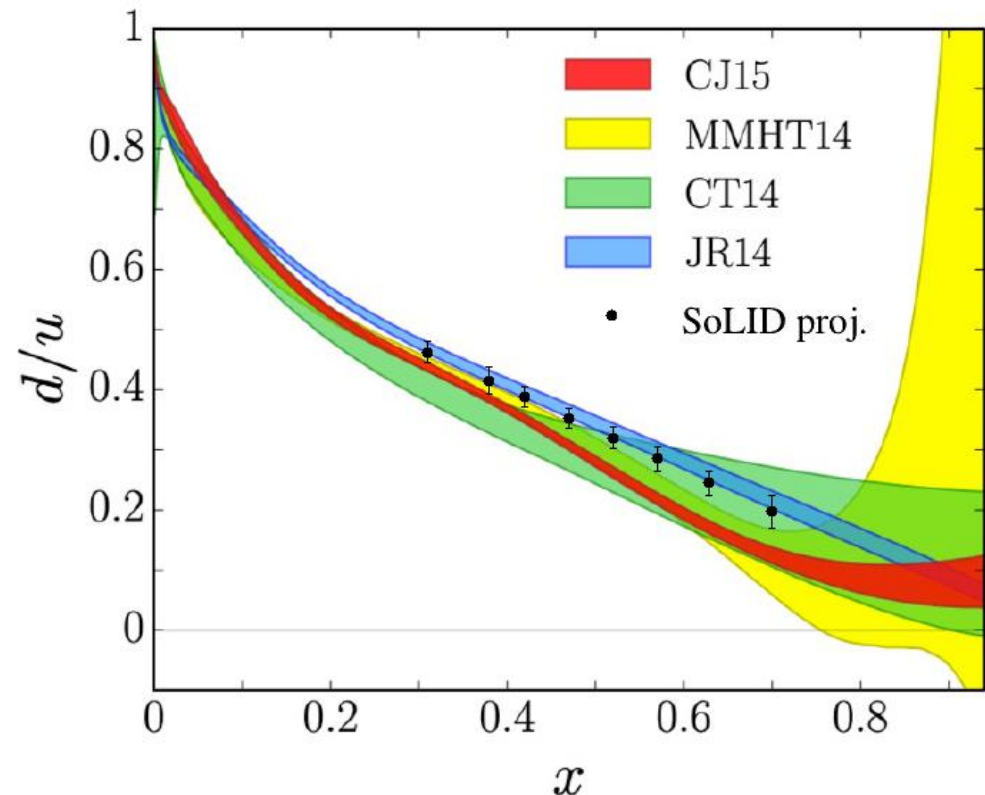

# $J/\psi$ : Gluon Field, Proton Mass and Mass Radius

Experiment with  $\text{LH}_2$  target overall compatible with SoLID SIDIS configuration

- **Electroproduction trigger:** 3-fold coincidence of  $e^-$ ,  $e^-e^+$
- **Photoproduction trigger:** 3-fold coincidence of  $p$ ,  $e^-e^+$
- **Additional trigger:** 4-fold coincidence of  $ep$ ,  $e^-e^+$
- And (inclusive) 2-fold coincidence  $e^+e^-$

$$e^- + p \longrightarrow e^- + p + J/\psi (e^+ + e^-)$$

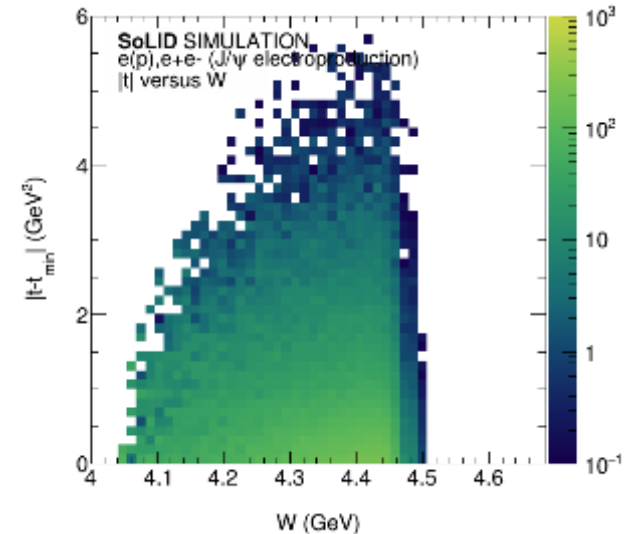
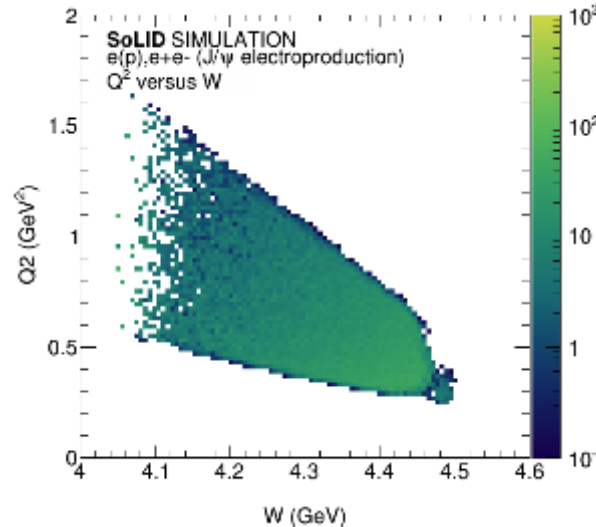
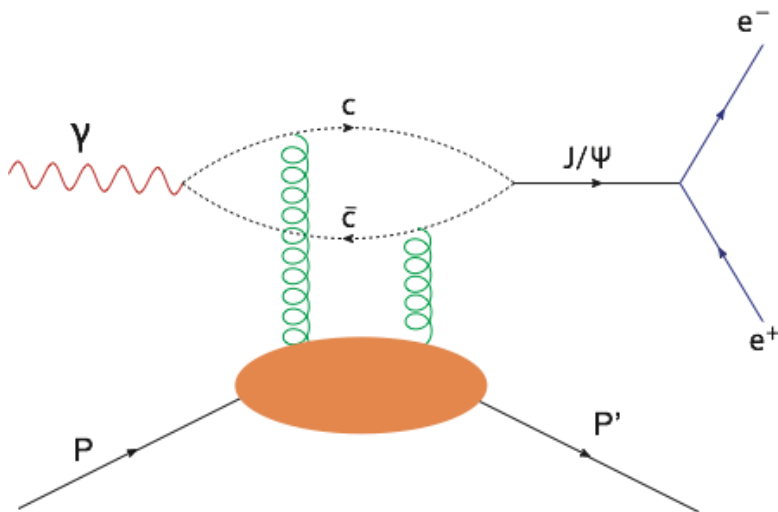
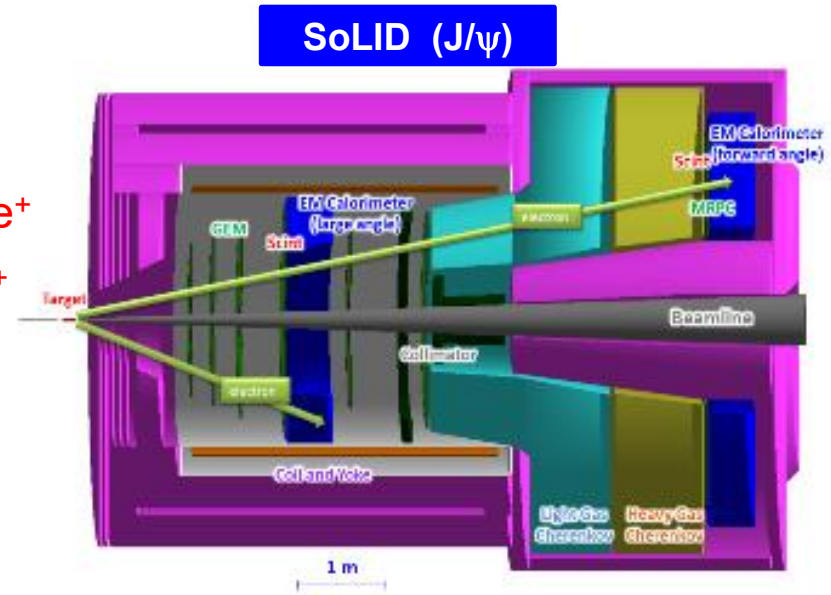

# $J/\psi$ : Gluon Field, Proton Mass and Mass Radius

## SoLID precision projection

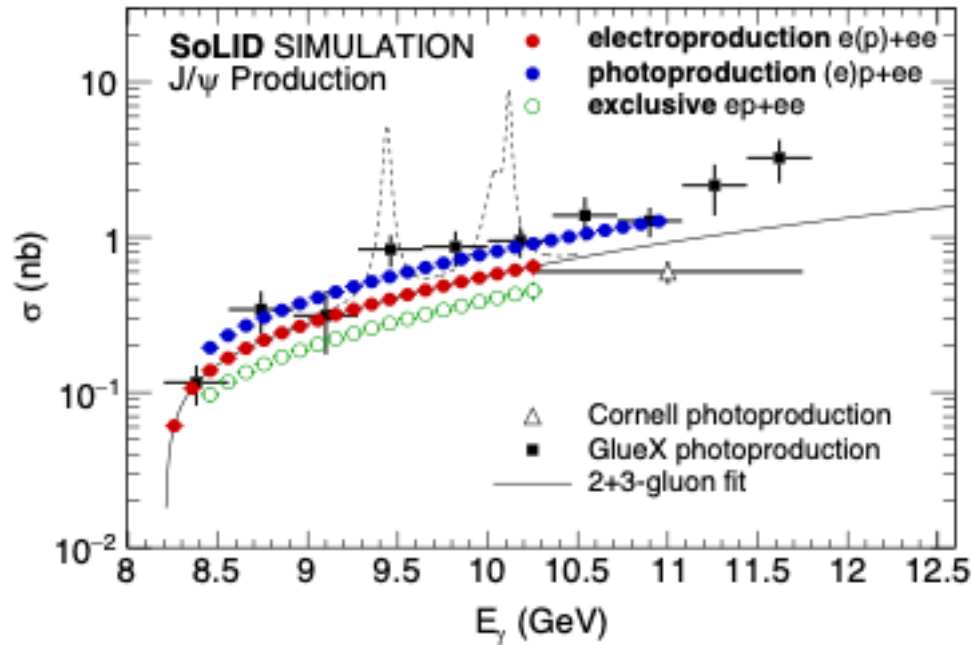

## Gluon (trace anomaly) contribution to proton mass

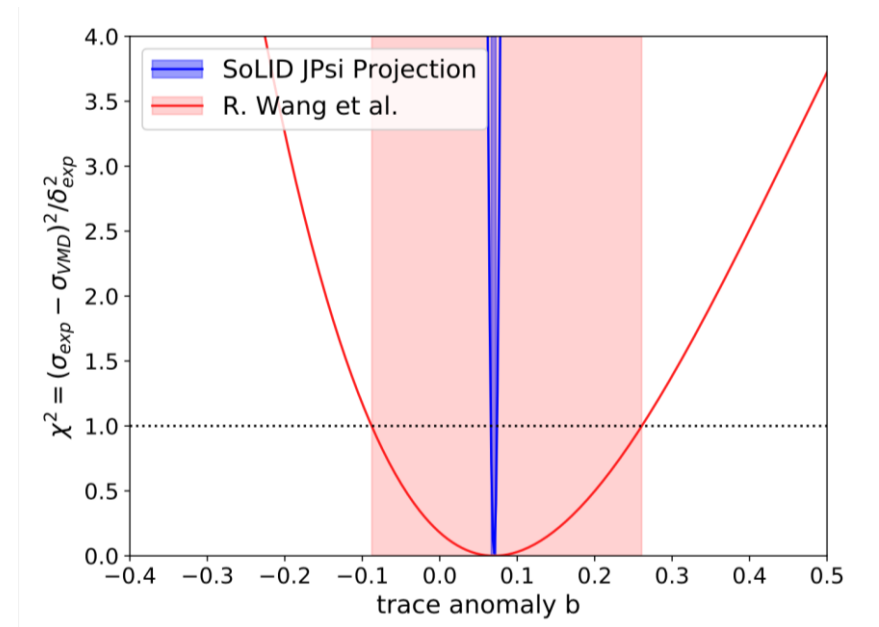

## Mass Radius

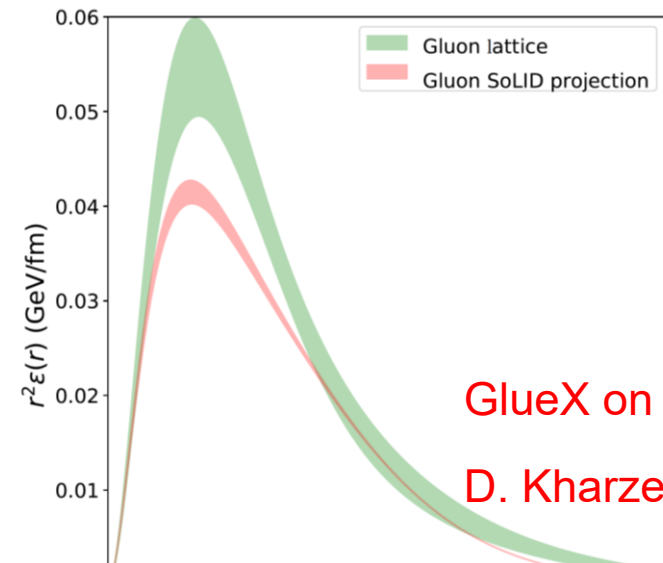

S. Joosten and Z.E. Meziani, PoS 308 (2017)

Gryniuk, Joosten, Meziani, and Vanderhaeghen, PRD 102, 014016 (2020) (for update)

M. Boer, et al., arXiv:hep-ph2512.15064 (2025)

GlueX on  $J/\psi$ ; Ali et al., PRL 123, 072001 (2019)

D. Kharzeev, PRD 104, 054015 (2021)

# *J/ψ parasitic: Strangeness D-term Potential Studies*

- Nucleon  $D$ -term fundamental quantity
  - One of GFFs
  - Appears in parametrization of nucleon energy-momentum tensor
  - Encodes information on pressure and shear forces distribution
- Proton energy-momentum tensor  $T^{\mu\nu}$  decomposition to contain quark and gluonic components
  - with each component having GFFs:  $A(t)$ ,  $B(t)$ ,  $D(t)$
  - $D(0)$  usually called nucleon  $D$ -term
- $D(t)$  decomposition given by  $D(t) = D_u(t) + D_d(t) + D_s(t) + D_g(t)$ 
  - Has strange-quark piece
  - $D_s(0)$  having pivotal role in characterizing nucleon's mechanical stability

# $J/\psi$ parasitic: Strangeness $D$ -term Potential Studies

Strangeness  $D_s$ -term theory

Hatta and Strickman, PLB 817,136295 (2021)

Hatta, Klest, Passek-K., and Schoenleber, Progress of Theoretical and Experimental Physics, 1 (2025)

- $\phi$ -meson electroproduction near threshold and at high photon virtualities studied in GPD factorization framework
  - For calculations, hard scale considered at  $Q^2 \gtrsim 4 \text{ GeV}^2$
  - Also,  $|t| \lesssim Q^2/3$ , as the limit of applicability of calculations
  - Higher-twist corrections could be very large above this threshold

Strangeness  $D_s$ -term experiment (Hall C)

Henry Klest, et. al., *Studying the Strangeness  $D$ -Term in Hall C via Exclusive  $\phi$  Electroproduction*, PR12-25-007 Rating A-

- Measure  $|t|$ -dependence of exclusive  $\phi$ -meson electroproduction cross section
  - proposed as an observable sensitive to  $D_s$ -term

# *J/ψ parasitic: Strangeness D-term Potential Studies*

- Contribution of strangeness to total  $D$ -term presently unknown
  - different arguments favoring  $D_s$  being large or being small
  - even having opposite sign from total  $D$ -term
  - Hall C measurement to distinguish between these hypotheses
- SoLID may assist as well
  - Use its  $J/\psi$  setup and corresponding kinematics

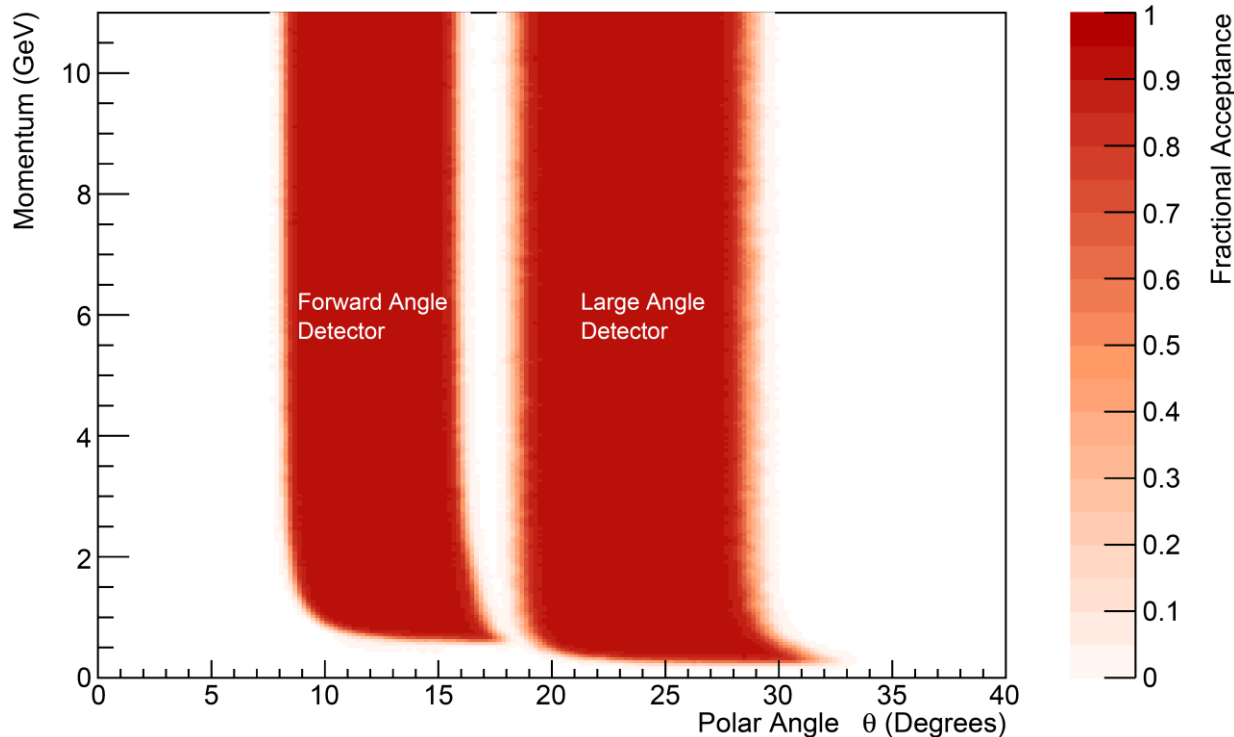

Hatta, Klest, Passek-K., and Schoenleber, Progress of Theoretical and Experimental Physics, 1 (2025)

SoLID acceptance for charged particles in momentum (up to 11 GeV) and polar angle

# $J/\psi$ parasitic: Strangeness D-term Potential Studies

Y. Hatta, Workshop on Vector Quarkonia as Pressure Gauges; JLab Mar 26-27, 2026

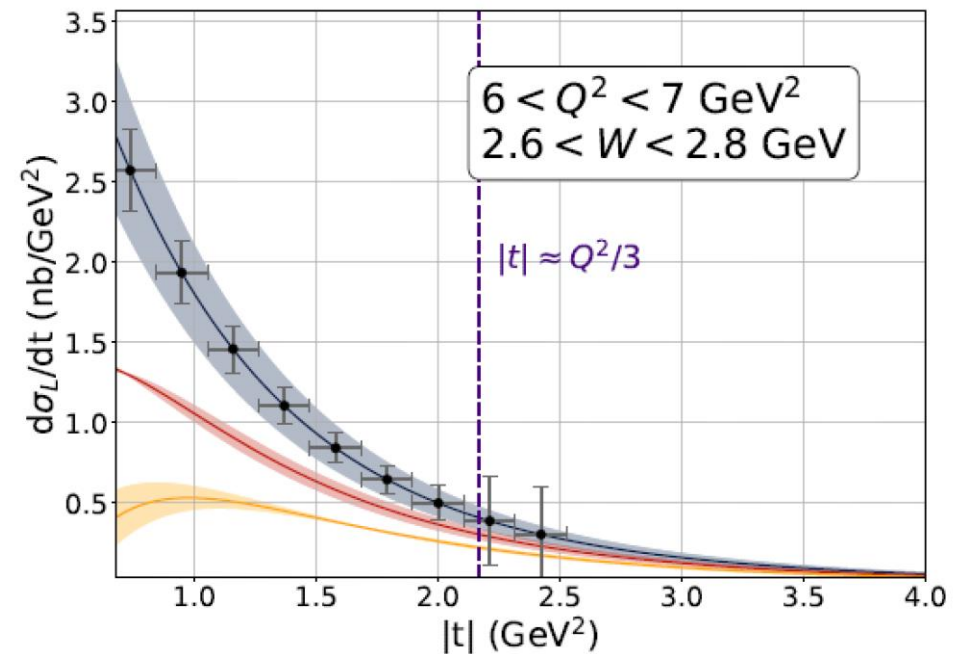
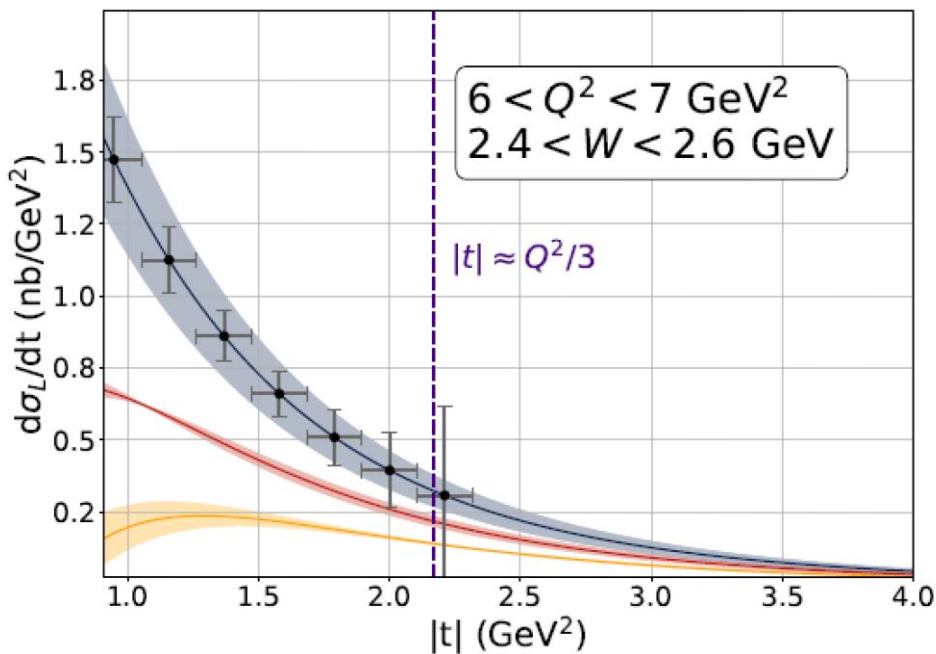

MC-simulated  $\phi$ -electroproduction at SoLID:  
systematics dominated, roughly 10%

# SIDIS: L / T Separation Potential Studies

$R = s_L/s_T$  in SIDIS

- Possible source of normalization mismatch in TMD fits with SIDIS data
- To understand the role of longitudinal photons in SIDIS

- Knowledge of  $R = \sigma_L/\sigma_T$  in SIDIS non-existing in principle !
- Unpolarized cross section in SIDIS:

$$\frac{d\sigma}{dx dy dz d\phi_h dP_{h,t}^2} = \frac{\alpha^2}{xyQ^2} \frac{y^2}{2(1-\varepsilon)} \left(1 + \frac{\gamma^2}{2x}\right) \left\{ F_{UU,T} + \varepsilon F_{UU,L} + \sqrt{2\varepsilon(1+\varepsilon)} \cos\phi_h F_{UU}^{\cos\phi_h} + \varepsilon \cos(2\phi_h) F_{UU}^{\cos(2\phi_h)} + \lambda_e \sqrt{2\varepsilon(1+\varepsilon)} \sin\phi_h F_{LU}^{\sin\phi_h} \right\}$$

- Integrate over  $f_h$ , unpolarized beam; only L and T terms remain  
SIDIS  $\rightarrow F(x, Q^2, z, P_T)$ ; DIS  $\rightarrow F(x, Q^2)$
- Integrate over  $z, P_T$ , hadron species;  $R_{SIDIS} \rightarrow R_{DIS}$ 
  - $R_{SIDIS}$  may vary with  $z, P_T$ ;  
Is  $R_{SIDIS}$  the same for  $p^+, p^-$  ( $K^+, K^-$ ) ? And the same for H and D targets ?

# SIDIS: L / T Separation Potential Studies

- Explore SoLID's kinematic coverage to overlap with part of Hall C  $R_{SIDIS}$  data region
- Require  $\Delta\varepsilon = \varepsilon(\text{high}) - \varepsilon(\text{low}) > 0.2$  in any selected  $(x, Q^2, z, P_T)$  bin to enable reliable Rosenbluth-type L/T separation
  - Larger  $\Delta\varepsilon$  preferred to extract  $R_{SIDIS}$
  - Random errors in  $\sigma_L$  magnified by  $\Delta\varepsilon$
- Difficulties:
  - any errors in  $Q^2$  and  $x$  reconstruction could mean that  $\varepsilon(\text{high})$  and  $\varepsilon(\text{low})$  bins did not correspond to each other
  - assigned  $Q^2$  and  $x$  values for these two bins to be wrong by different amounts
  - extracted separated cross sections to be incorrect by much more than their statistical uncertainties

# SIDIS: L / T Separation Potential Studies

Need to generate  $\Delta\varepsilon$  map as functions of  $P_T$  and  $x$

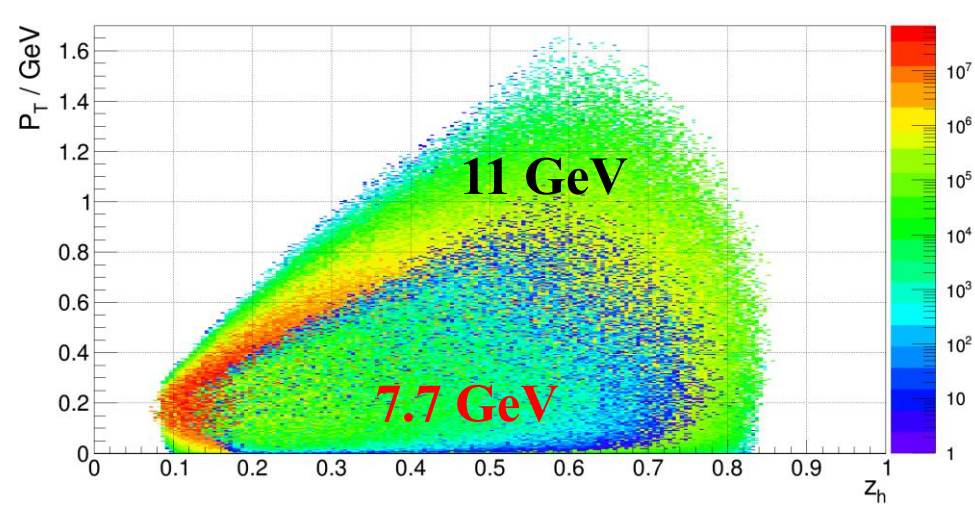
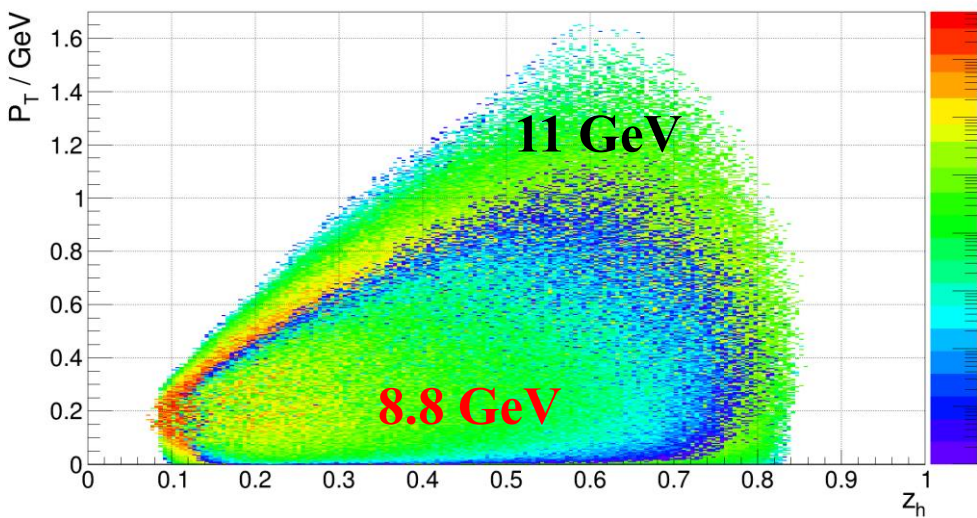
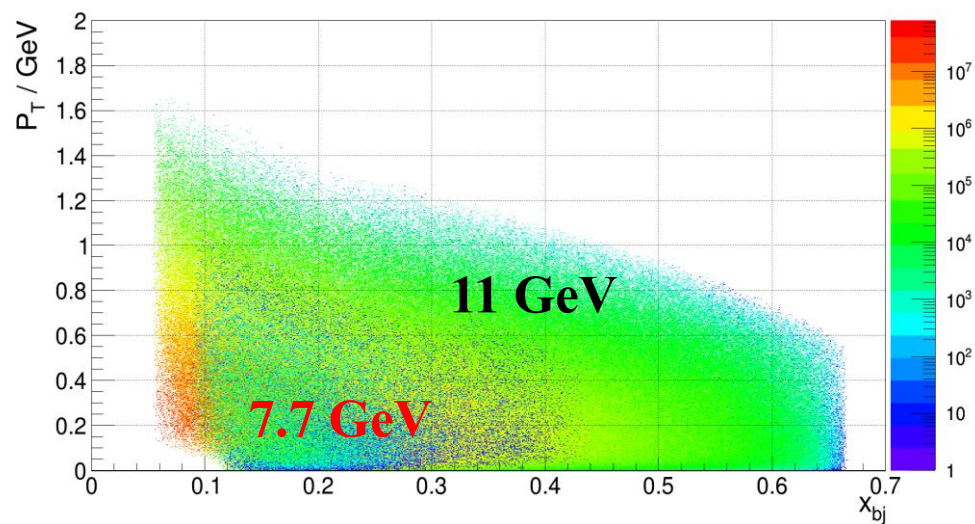
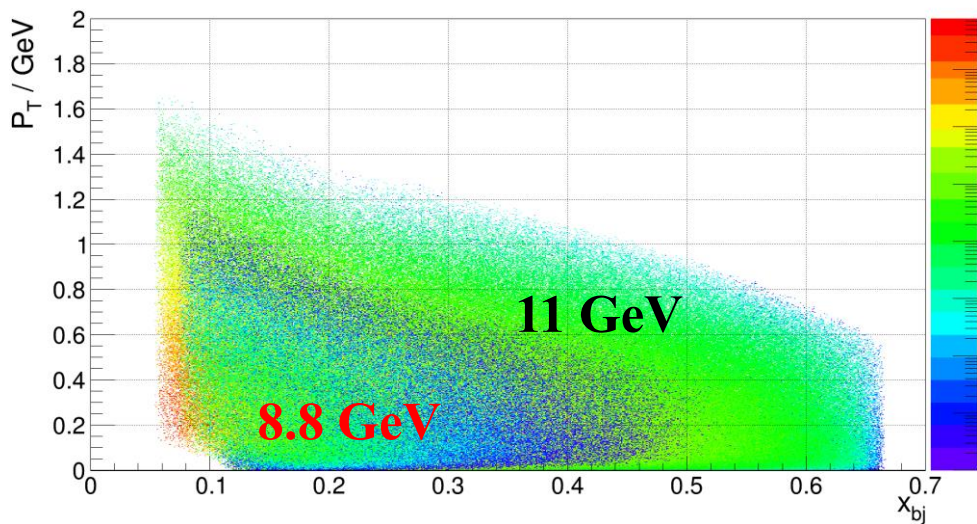

$P_T$  Coverage

# Summary and moving forward

- SoLID: **Large acceptance** device to handle **very high luminosity** and allow full exploitation of JLab 12 GeV potential
  - pushing the limit of the intensity frontier for Cold QCD
- SoLID: Rich and vibrant science program complementary and synergistic to proposed EIC science program
  - Three pillars on 3D (TMDs/GPDs), PVDIS and  $J/\psi$  production**
- However, given current budget situation and DOE not likely to start new projects for next few years
  - SoLID will adopt multi-stage approach
  - First stage: with minimal setup to run its  $J/\psi$  program
  - Other stages to come later

<https://solid.jlab.org/>

---

# Backups

# Spin: Run-group Experiments

## Approved experiments

- Run-group experiment  $d_2^n$
- Run-group experiment  $A_y^n$  projections, in comparison with world data (Phys. Rev. Lett. **113**, 022502 (2014) )
- Run-group experiment polarized Sea/PDFs

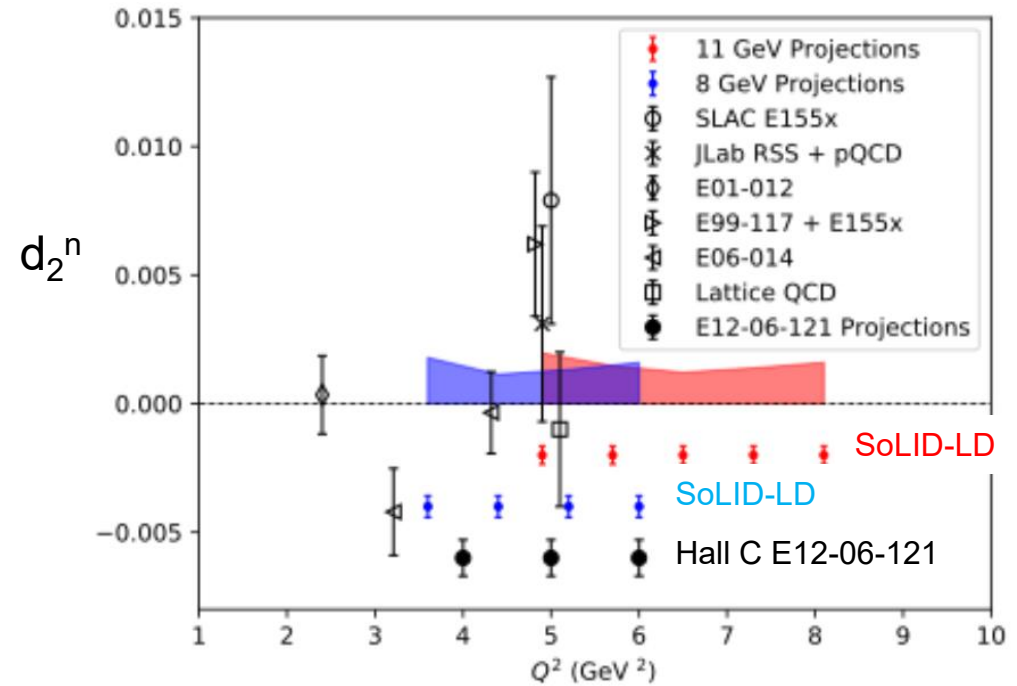

## SoLID He3 projection

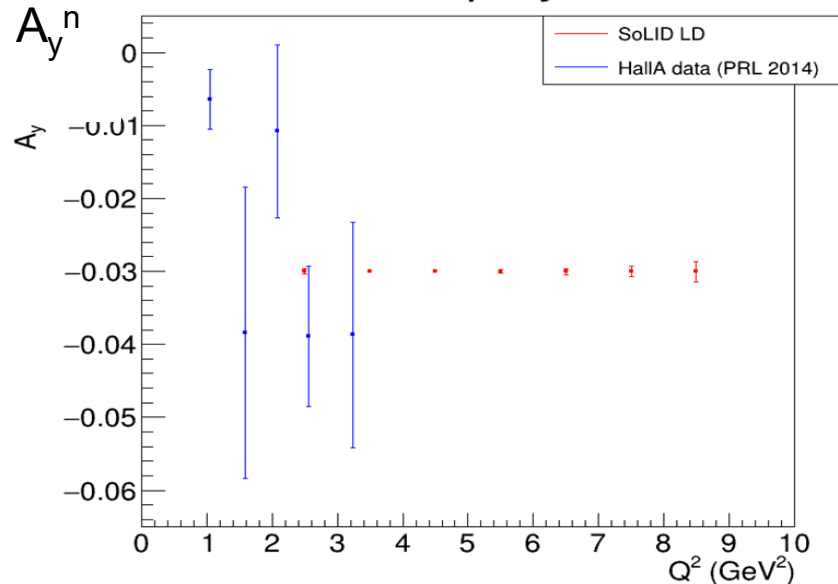

$\Delta d$  and  $\Delta \bar{d}$  with polarized <sup>3</sup>He

World fit and SoLID impact by JAM group

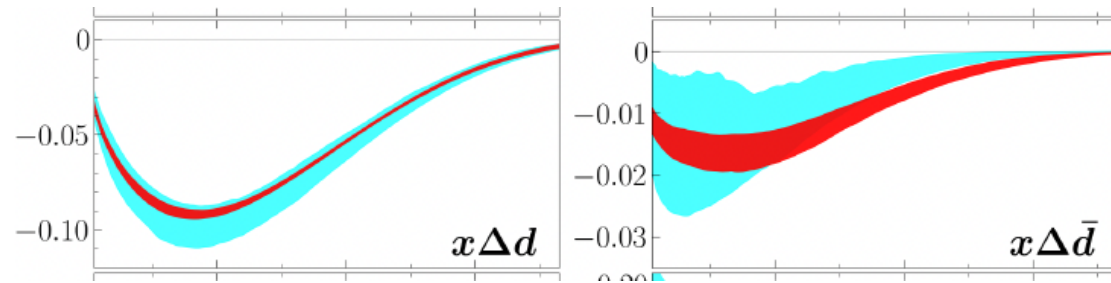

# $J/\psi$ parasitic: Strangeness $D$ -term Potential Studies

SoLID,  $\sqrt{s} = 4.46$  GeV

- NLO,  $D_S = 0.0$
- NLO,  $D_S = -0.5$
- NLO,  $D_S = -1.0$
- ⊕ Simulated Data (Stat. ⊕ Sys. Unc.)

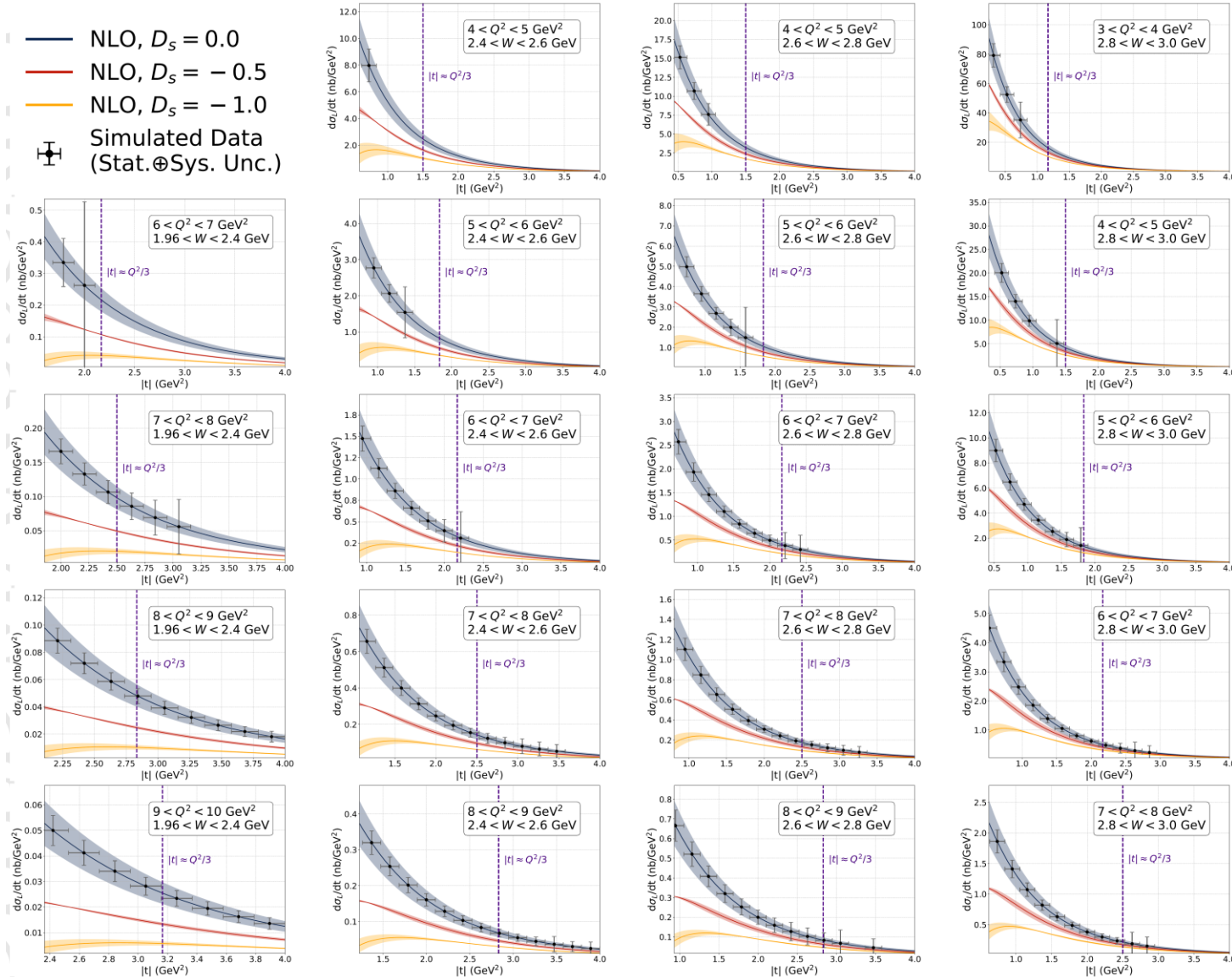

Hatta, Klest, Passek-K.,  
and Schoenleber,  
Progress of Theoretical  
and Experimental  
Physics, 1 (2025)

FIG. 15: Projected results at SoLID for the  $\gamma_L^* + p \rightarrow \phi + p$  cross section, differential in  $|t|$  and  $Q^2$  in the near-threshold regime. The assumed integrated luminosity is  $43.2 \text{ ab}^{-1}$ . The first (leftmost) column shows 4  $Q^2$  bins for  $W = 2.18$ , while the subsequent columns each represent a bin in  $W$  with five  $Q^2$  bins. Note that the accessible range in  $Q^2$  changes in each column due to the kinematic dependence on  $W$ . The purple dashed line is drawn at  $|t| \approx Q^2/3$ , where  $Q^2$  is assumed to be the bin center.

# $J/\psi$ parasitic: Strangeness D-term Potential Studies

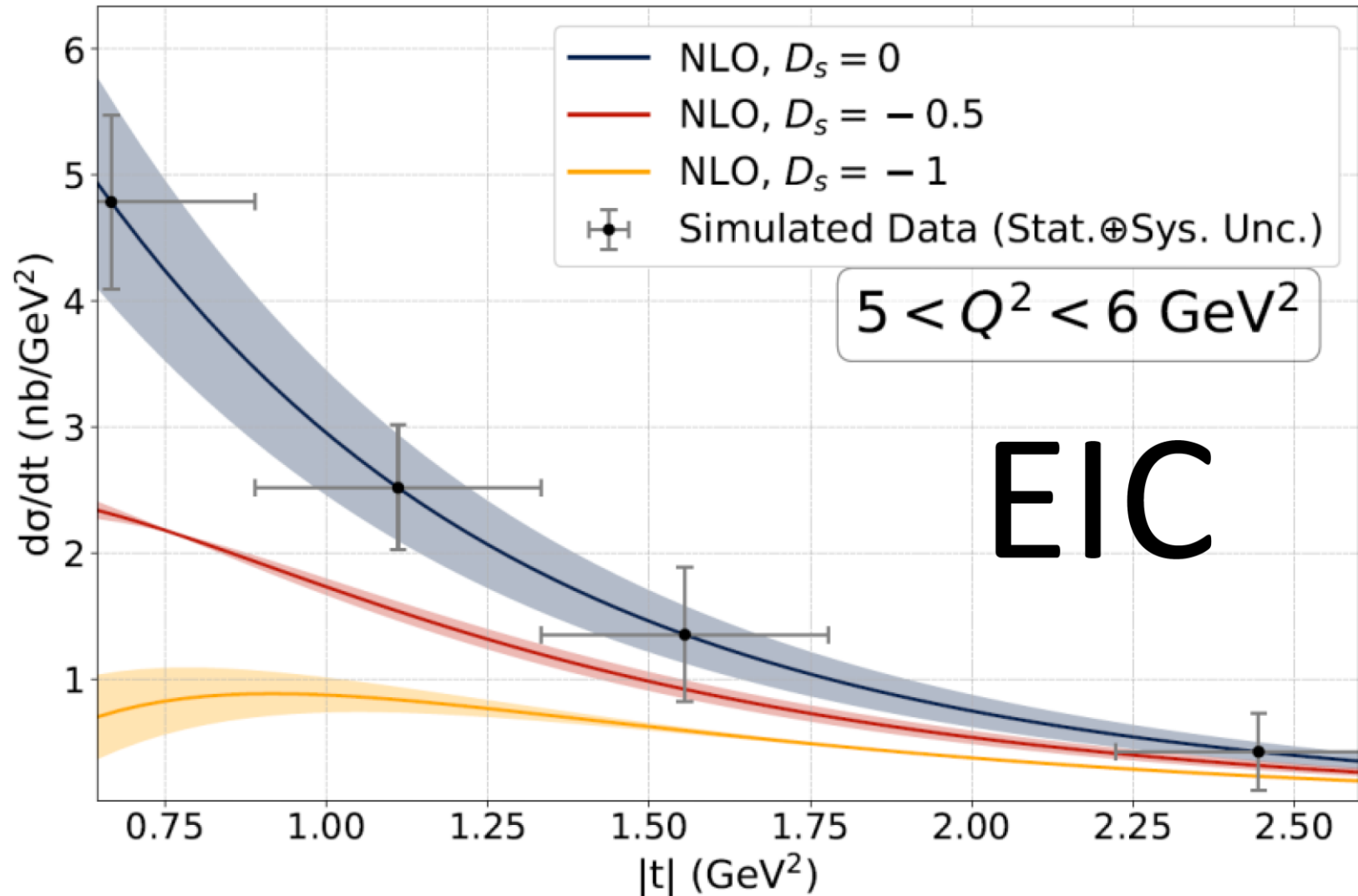

MC-simulated  $\phi$ -electroproduction  
at the EIC

Y. Hatta, Workshop on Vector Quarkonia as  
Pressure Gauges; JLab Mar 26-27, 2026

# SIDIS: L / T Separation Potential Studies

- L/T separation not possible for CLAS12 / HERMES, e.g., in exclusive  $p(e, e'\pi)n$  channel
  - angular and energy resolutions are not sufficiently good
- SHMS+HMS in Hall C can do Rosenbluth separations
  - absolute spectrometer angles (both in-plane and out-of-plane) at about 1mr
  - absolute beam and particle momentum calibrations at about 0.1%
- SoLID L/T-separation
  - Exclusive: challenging; SIDIS: potentially feasible, needs study
- Carry out simulation studies and uncertainty propagation to see if SoLID reaches similar (or, not much larger) point-to-point systematic uncertainties ( $\sim 1.1\text{--}1.6\%$ )
  - model expected uncertainties in extracted  $\sigma_L$  and  $\sigma_T$ , based on realistic estimates of precision with which detected particles' four-momenta are known
  - follow Hall C procedure relying on extensive e+p coincidence elastic data to study and constrain these uncertainties

# SIDIS: L / T Separation Potential Studies

## Check $\Delta\varepsilon$ with SoLID

- As mentioned, explore SoLID kinematic coverage to partially overlap with Hall C R-SIDIS data, while preserving SoLID's unique access to higher  $P_t$  region
- Study  $P_t$  coverage with 11 GeV and 8.8 GeV beams as a starting point; Identify bins with sufficient  $\varepsilon$  separation and high acceptance

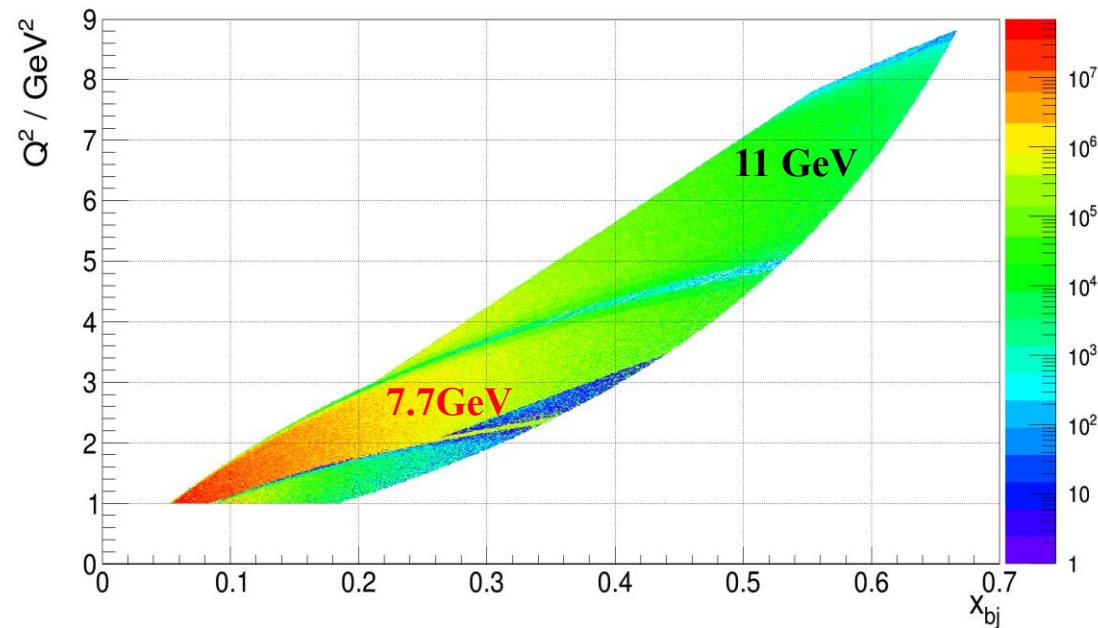
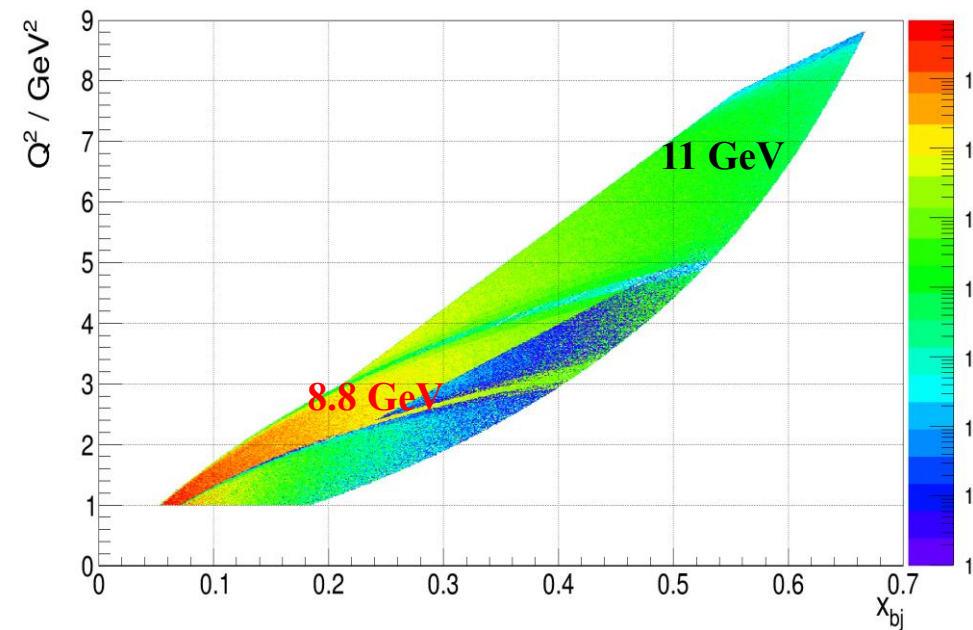

# SIDIS: L / T Separation Potential Studies

## Multiplicities: $P_T$ Dependence at Hall C kinematics

Curves from MAP collaboration, scaled by factor  $k$

MAP curves from Gaussian plus weighted Gaussian for  $P_t$  dependence

Generally good agreement !

- $\pi^+$  from p
- $\pi^+$  from d
- $\pi^-$  from d
- $\pi^-$  from p

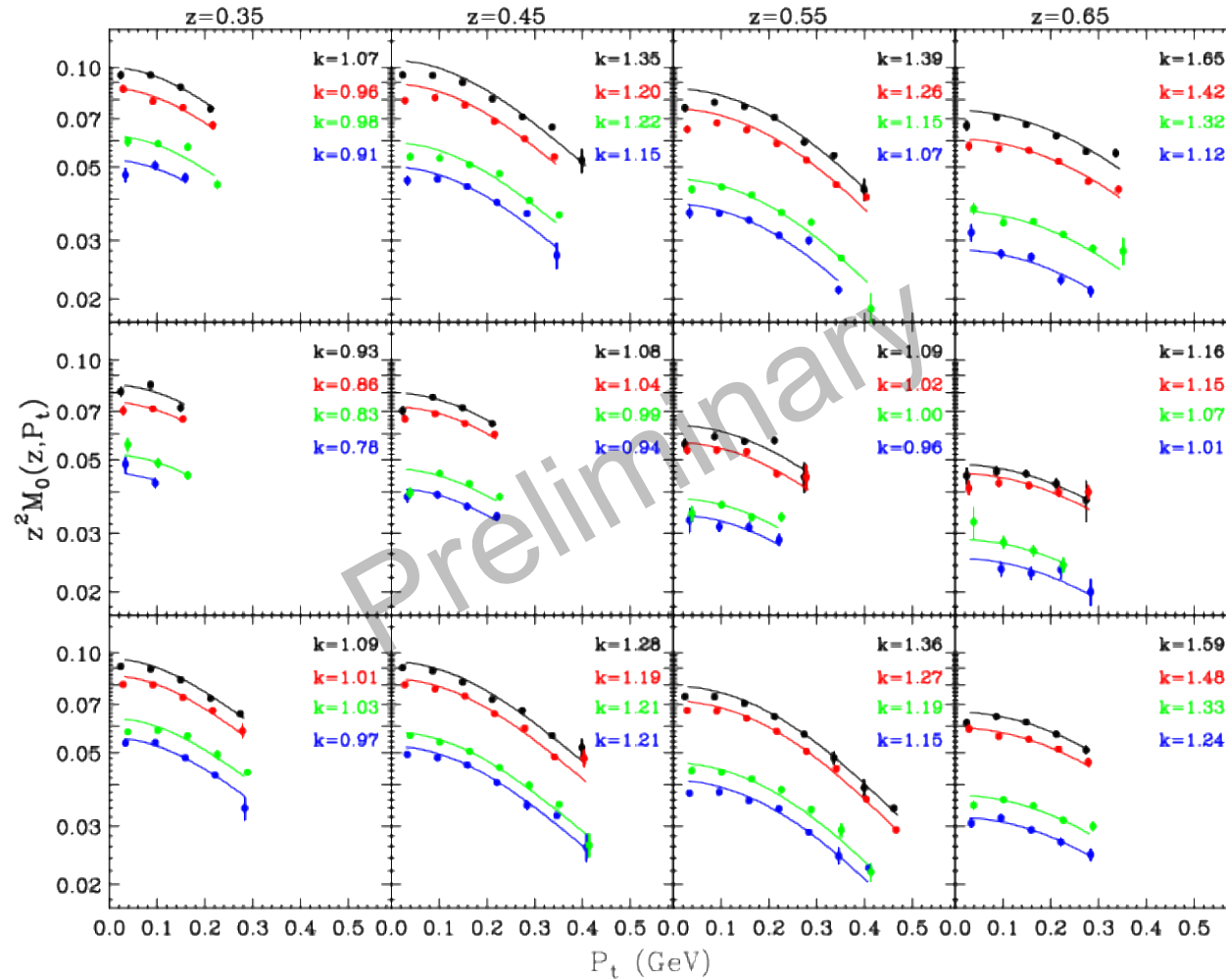

Slide from the talk of Dave Gaskell, JLUO Meeting June 24-26, 2025

# Physics and pre-Project Development of SoLID

- **Rich physics program: (2010-now)**

- 6 SoLID experiments approved by PAC with high rating ( 5 A, 1 A-)
  - 3 SIDIS (3d structure), 1 PVDIS (search for new physics),
  - 1 threshold  $J/\psi$  (gluon force), 1 A-n (new phenomena), +
  - 1 C1 conditional approved with A rating (DDVCS)
  - 1 C2 conditional approval (PVEMC)
  - + 8 run-group experiments (3d/spin structure)

- **Pre-conceptual design, Pre-R&D and status**

- 2014: pCDR submitted to JLab with cost estimation, updated in 2017, 2019
  - Director's Reviews in 2015, 2019 and 2021

- 2015: LRP, highlighted, one of the MIEs recommended

- 2020: SoLID MIE (with updated pCDR/estimated cost) submitted to DOE

- 2021: DOE **Science Review for SoLID, positive feedback**

- 2023: Long Range Plan, highlighted prominently, one of the recommendations

- 2024: Facility Review: Ready to Launch

- 2020-2026: DOE funded/JLab supported pre-R&D activities

# Strong Collaboration

- 270+ collaborators, 70+ institutions from 13 countries
- Large international participations and anticipate contributions
- Strong theory support

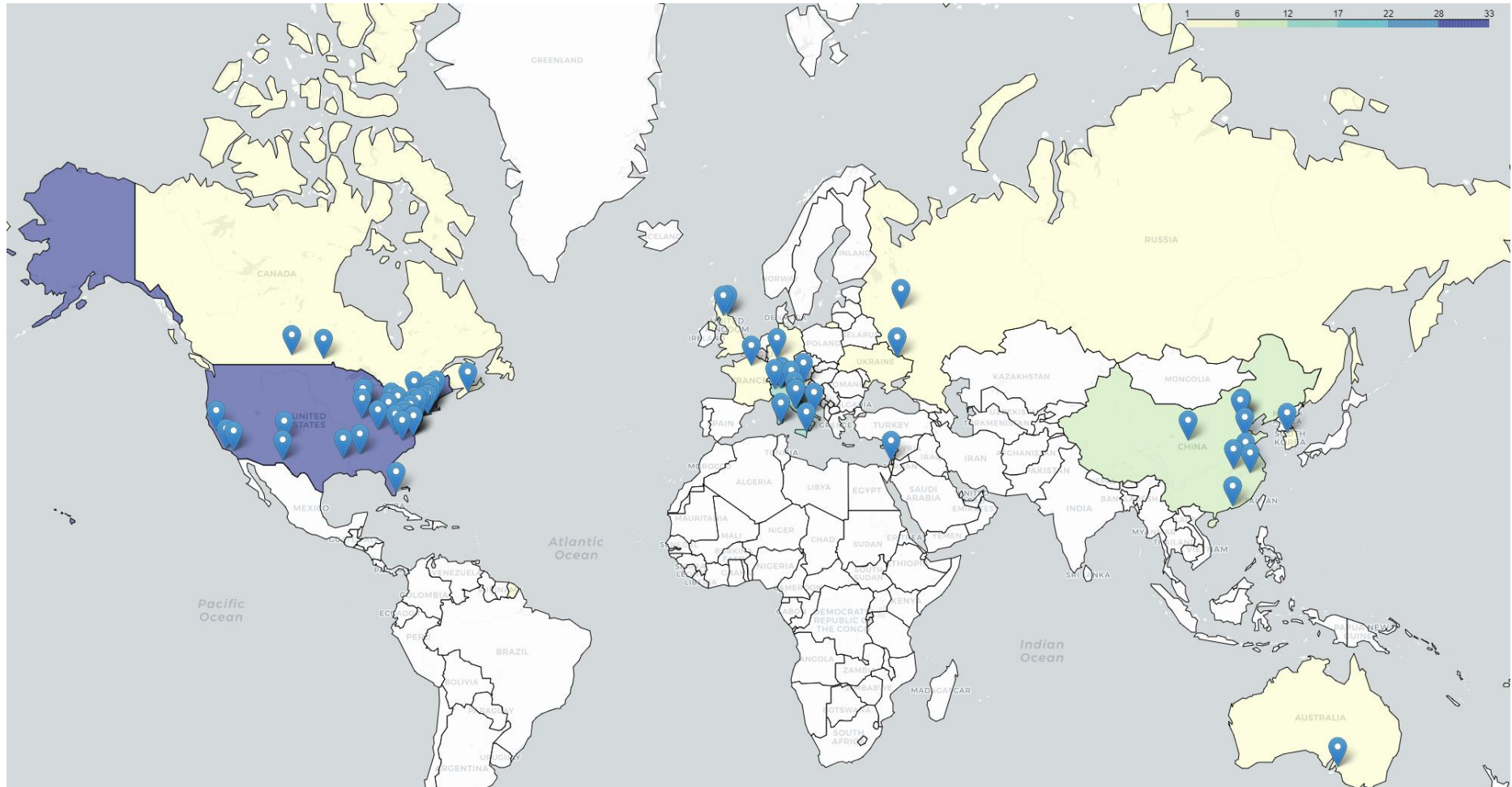

full list available at <https://solid.jlab.org/collaboration/full.html>

# NSAC Long Range Plan & Community Strong Support

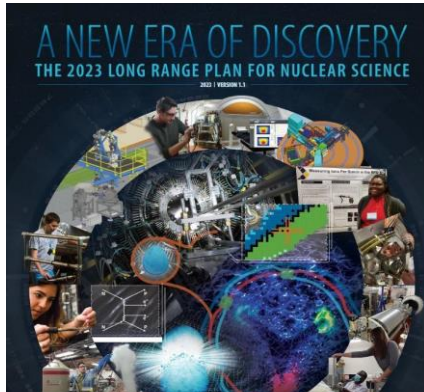

## NSAC 2023 LRP Town Meetings – QCD

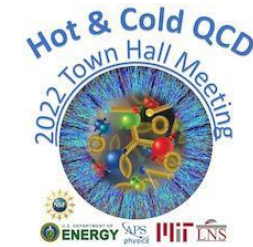

### 1 | EXECUTIVE SUMMARY

#### RECOMMENDATION 4

**We recommend capitalizing on the unique ways in which nuclear physics can advance discovery science and applications for society by investing in additional projects and new strategic opportunities.**

Today's investments enable tomorrow's discoveries, with corresponding benefits to society. We underscore the importance of innovative projects and emerging technologies to extend discovery science, which plays a unique role in supporting national needs.

#### 1.3.1. Opportunities to Advance Discovery

Strategic opportunities exist to realize a range of projects that lay the foundation for the discovery science of tomorrow. These projects include the 400 MeV/u energy upgrade to FRIB (FRIB400), the Solenoidal Large Intensity Device (SoLID) at Jefferson Lab, targeted upgrades for the LHC heavy ion program, emerging technologies for measurements of neutrino mass and electric dipole moments, and other initiatives that are presented in the body of this report.

#### Recommendation 1: Capitalizing on past investments

(Yes: 335; No: 3; No Answer: 4)

The highest priority for QCD research is to maintain U.S. world leadership in nuclear science for the next decade by capitalizing on past investments. Maintaining this leadership also requires recruitment and retention of a diverse and equitable workforce.

**We recommend support for a healthy base theory program, full operation of the CEBAF 12-GeV and RHIC facilities, and maintaining U.S. leadership within the LHC heavy-ion program, along with other running facilities, including the valuable university-based laboratories, and the scientists involved in all these efforts.**

This includes the following, unordered, programs:

- The 12-GeV CEBAF hosts a forefront program of using electrons to unfold the quark and gluon structure of visible matter and probe the Standard Model. We recommend executing the CEBAF 12-GeV program at full capability and capitalizing on the full intensity potential of CEBAF by the construction and deployment of the Solenoidal Large Intensity Device (SoLID).

# *Broad Impact of SoLID*

---

- Science Impact: valence-sea (SoLID) and sea-quark/gluon (EIC) regions required to fully unravel the 3-d structure of the nucleon and search for new physics
- Technologies: testing grounds for advanced detector, DAQ/electronics and computing technologies including AI/ML
- Workforce development critical for future success of nuclear physics including EIC
- STEM Workforce development for energy, medicine, national security and data science