

# Threshold charmonium production with GlueX

## ... and gluon Gravitational Form Factors

*Lubomir Pentchev*

- History of  $J/\psi$  photoproduction and the comeback of threshold measurements at JLab
- “Rosenbluth” (kinematic) separation of the  $J/\psi$  near-threshold photoproduction - **experimental test** of energy independence of Form Factors
- Relation to gluon Gravitational Form Factors (GFFs) **based on theory** and **comparison to lattice results**
- Open questions about reaction mechanism
  
- Observation of **C-even** ( $\chi_c$ ) photoproduction with GlueX
- Photoproduction of charmonia with **opposite-to-photon parity**
  - what does it mean?
  - complementarity to **C-odd** ( $J/\psi$ ) charmonium photoproduction
  
- Future measurements at GlueX
  - GlueX phase III - charmonium at threshold
  - Why we need CEBAF energy upgrade

# >50 years $J/\psi$ photoproduction and comeback of threshold measurements

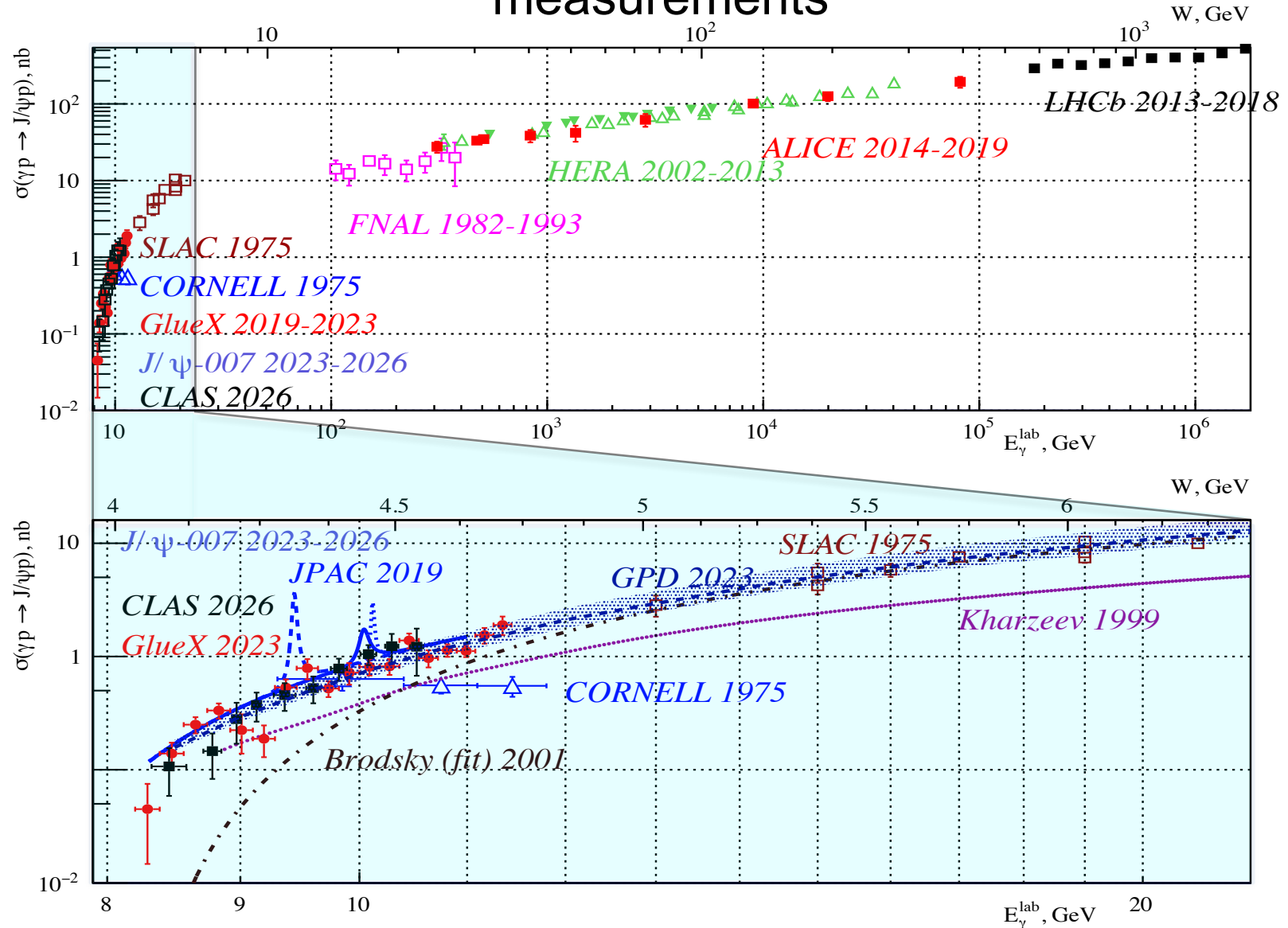

# Charmonium photoproduction in Hall D with 12 GeV beam

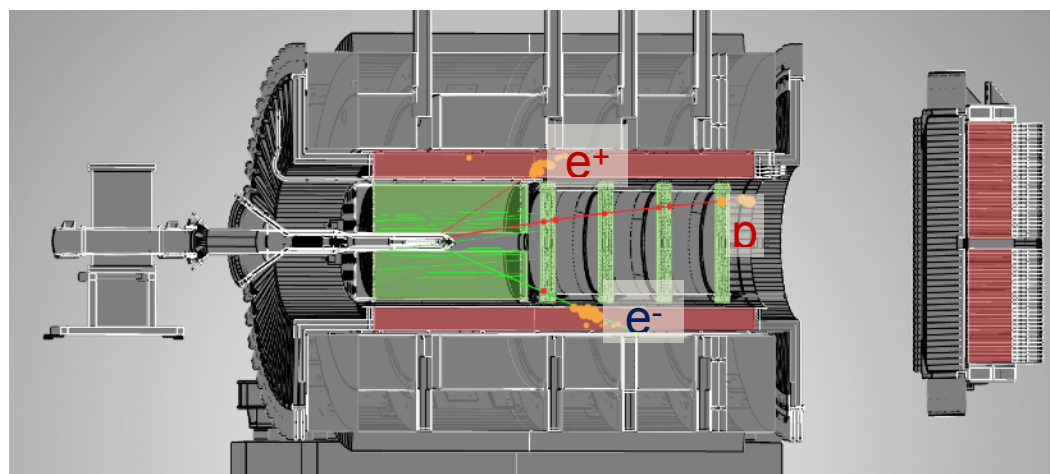
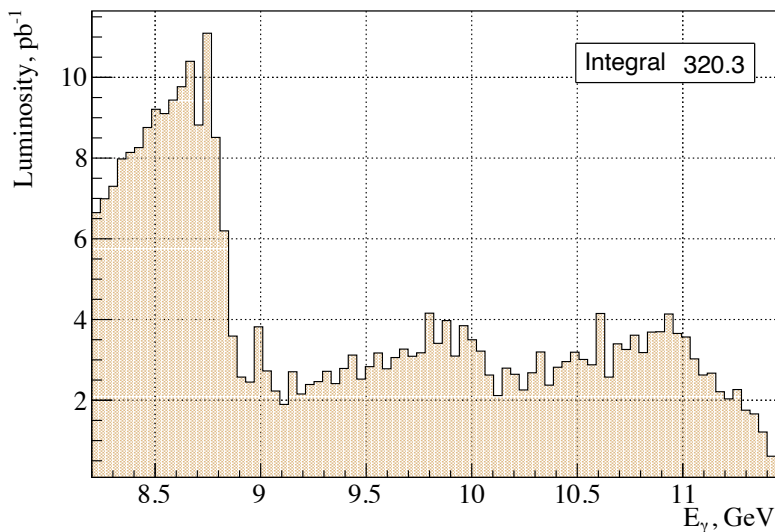
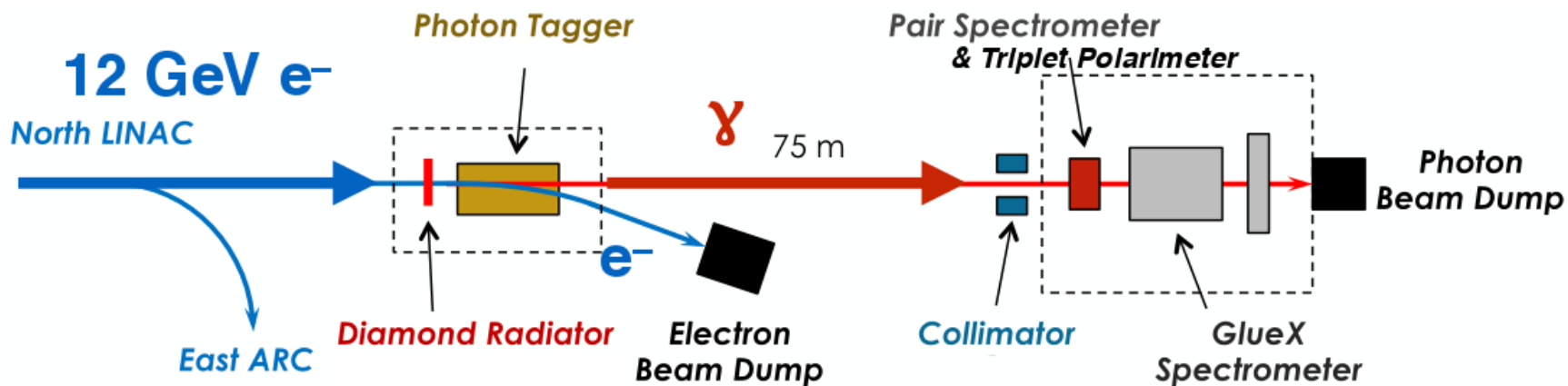

$$\gamma p \rightarrow J/\psi p \rightarrow e^+ e^- p$$

- Linearly-polarized photon beam from coherent Bremsstrahlung off thin diamond
- Photon energy tagged by scattered electron: 0.2% resolution
- Intensity:  $\sim 2 \times 10^7 - 5 \times 10^7 \gamma/sec$  above  $J/\psi$  threshold (8.2 GeV)

# Gluon Gravitational Form Factors

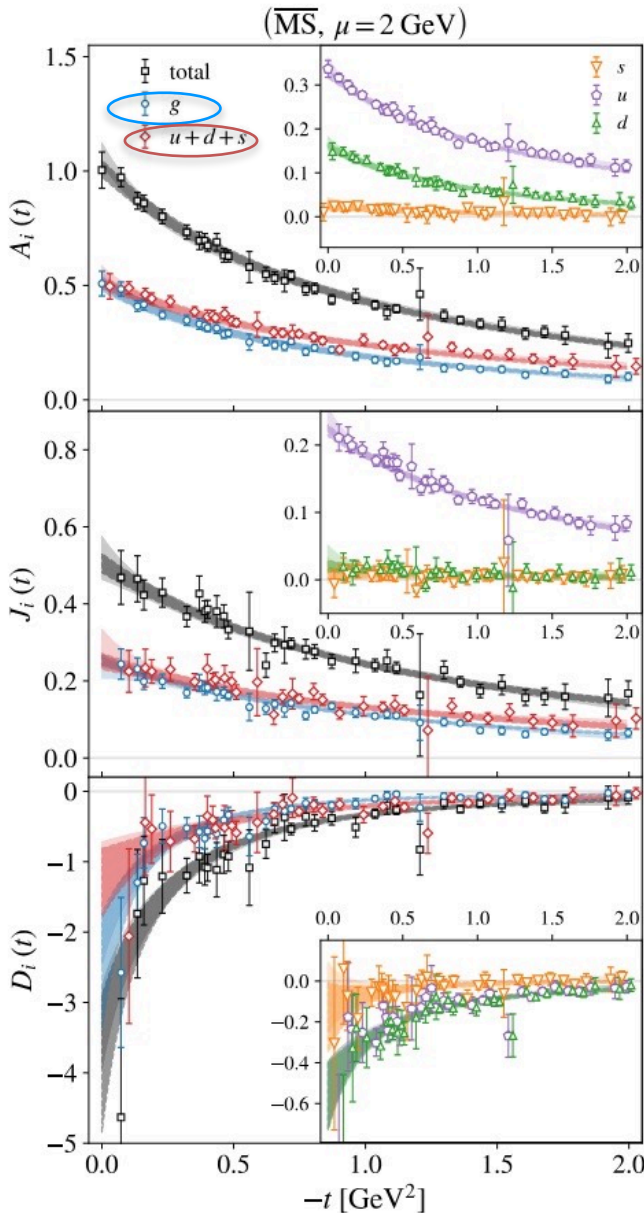

- Gluon contribution to the mechanical properties of the proton equally important as the quark one:

Lattice calculations of Gravitational Form Factors (GFFs) show similar contributions from **gluons (g)** and **quarks (u+d+s)**.

*Hackett, Pefkou, Shanahan arxiv:2310.08484 (2023)*

- Quark masses and kinetic energies of quarks and gluons are not enough to explain the mass of the proton: gluon condensate, or anomalous contribution to the mass of the proton is significant:

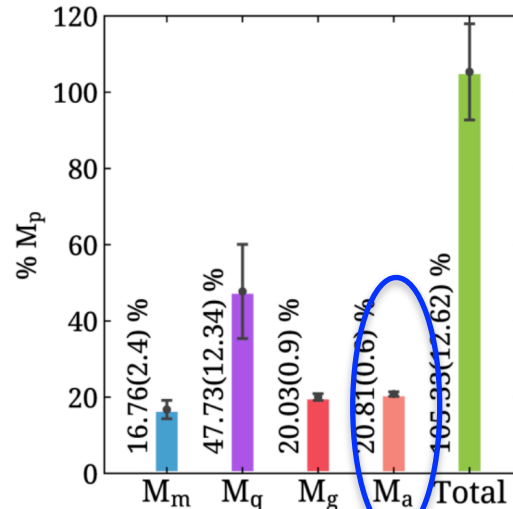

C. Alexandrou *et al.*, (ETMC), PRL 119, 142002 (2017)

C. Alexandrou *et al.*, (ETMC), PRL 116, 252001 (2016)

# Uniqueness of threshold charmonium photoproduction - GPD approach

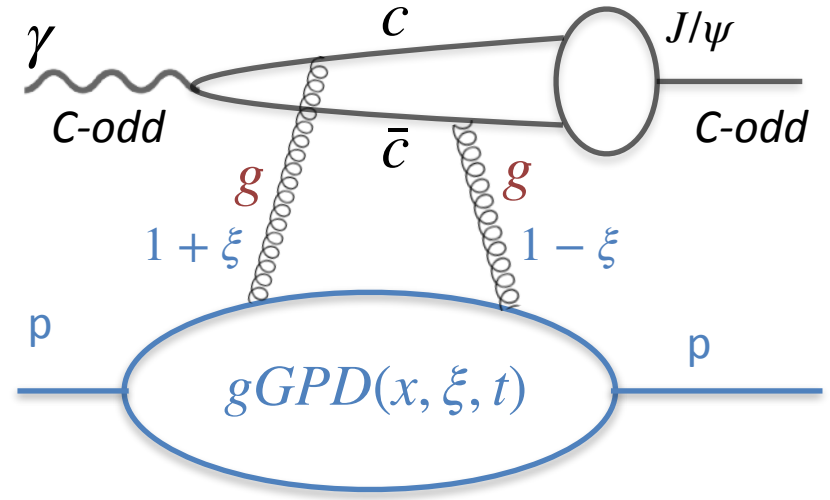
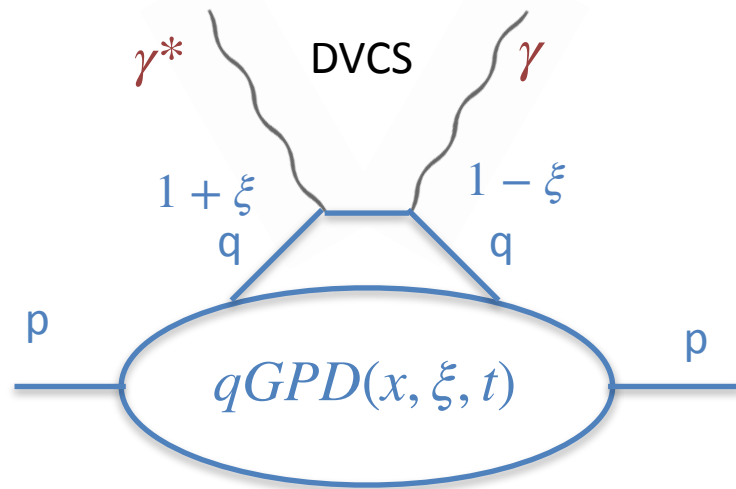

- Compton-like amplitudes, form-factors  $\mathcal{A}_g(t)$ ,  $\mathcal{B}_g(t)$ ,  $\mathcal{C}_g(t)$ , as in Deeply Virtual Compton scattering (DVCS)

However:

- gluon (not photon) probe
- Threshold kinematics is very different: **high momentum transfer  $t$  and skewness  $\xi$**
- In heavy-quark limit:  $t \rightarrow \infty$   $\xi \rightarrow 1$

**For  $\xi \rightarrow 1$  expansion in  $x/\xi$ :**

$$d\sigma/dt = F(E_\gamma)\xi^{-4}[G_0(t) + \xi^2 G_2(t) + \xi^4 G_4(t)] + \dots, \quad G_i(t) \text{ functions of } \mathcal{A}_g^{(2)}(t), \mathcal{B}_g^{(2)}(t), \mathcal{C}_g(t)$$

**In leading-moment approximation:**

gluon Gravitational Form Factors  $A_g(t)$ ,  $B_g(t)$ ,  $C_g(t)$  are leading terms of  $\mathcal{A}_g^{(2)}(t)$ ,  $\mathcal{B}_g^{(2)}(t)$ ,  $\mathcal{C}_g(t)$

# Gluon Gravitational Form Factors from experimental point of view

Test the main general property of Form Factors - they depend ONLY on  $t$

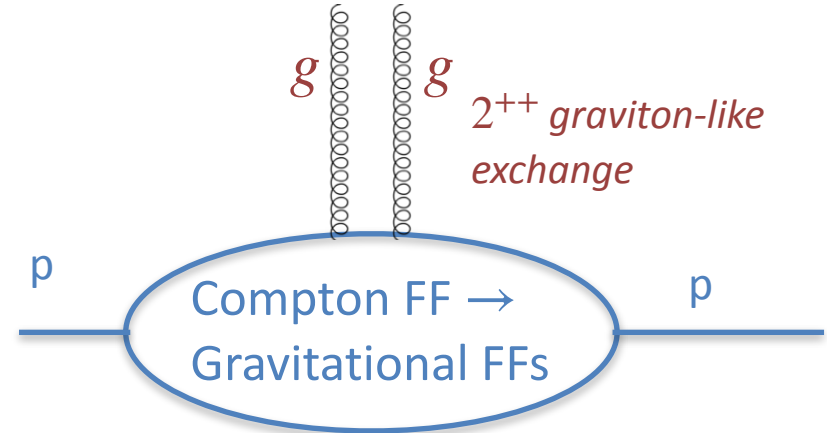
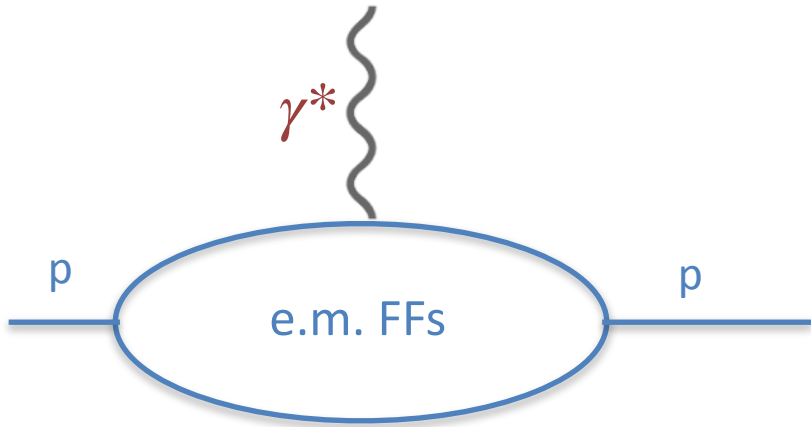

$$\left(\frac{d\sigma}{d\Omega}\right)_{ep \rightarrow ep} = \left(\frac{d\sigma}{d\Omega}\right)_M \frac{1}{(1+\tau)} \left[ G_E^2(t) + \frac{\tau}{\epsilon} G_M^2(t) \right]$$

$$\left(\frac{d\sigma}{dt}\right)_{\gamma p \rightarrow J/\psi p} = F(E_\gamma) \xi^{-4} [G_0(t) + \xi^2 G_2(t) + \xi^4 G_4(t)]$$

Model approach - fit dipole/tripole FFs (within some model) to data

$$G_E(t), G_M(t) \sim G_D(t) = \frac{1}{(1 + t/0.71 \text{GeV}^2)^2}$$

$$A_g(t), B_g(t), C_g(t) \sim \frac{1}{(1 + t/m_t^2)^{2(3)}}$$

Rosenbluth separation - data-driven kinematic FF extraction

$$\sigma_R = \frac{d\sigma}{d\Omega} / \left(\frac{d\sigma}{d\Omega}\right)_M \frac{\epsilon(1+\tau)}{\tau} = \frac{\epsilon}{\tau} G_E^2(t) + G_M^2(t),$$

$$\sigma_{R0} = \frac{d\sigma}{dt} \frac{\xi^2}{F(E_\gamma)} = \xi^{-2} G_0(t) + G_2(t) + \xi^2 G_4(t)$$

# Rosenbluth separation

$G_E^2(t)$  and  $\tau G_M^2(t)$  extraction

$ep \rightarrow ep$

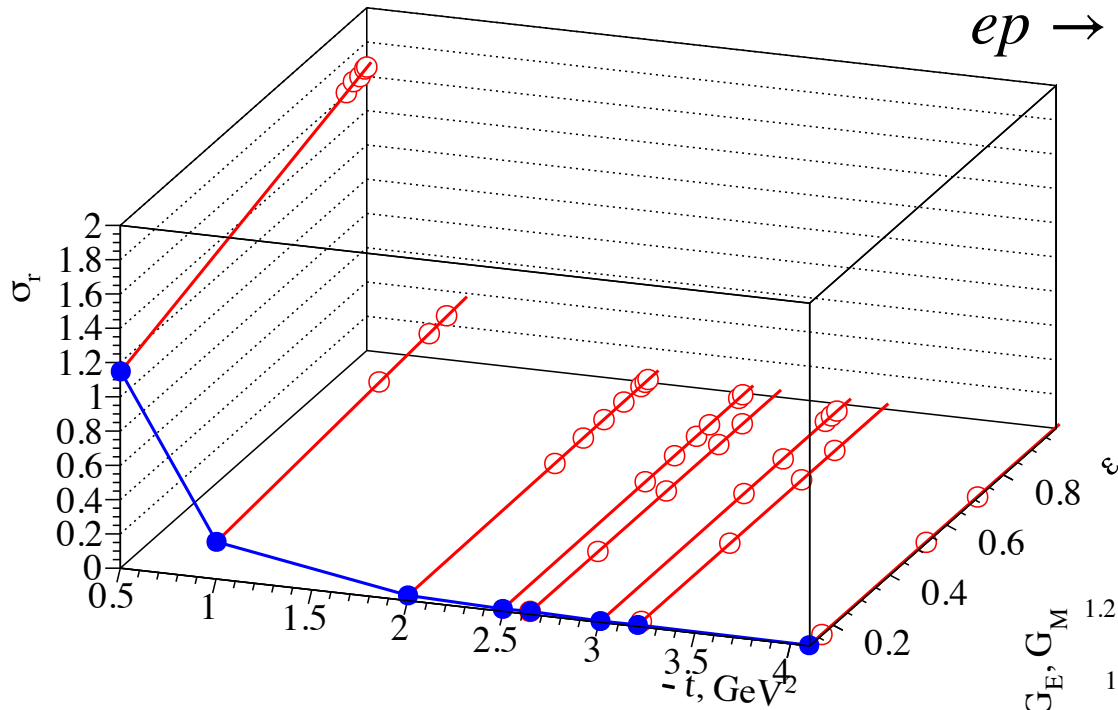

Data from:

*R.C.Walker et al. Phys.Rev.D 49, 11 (1994) - SLAC*

*I.A.Qattan et al. arXiv 2411.05201 (2024) - JLab*

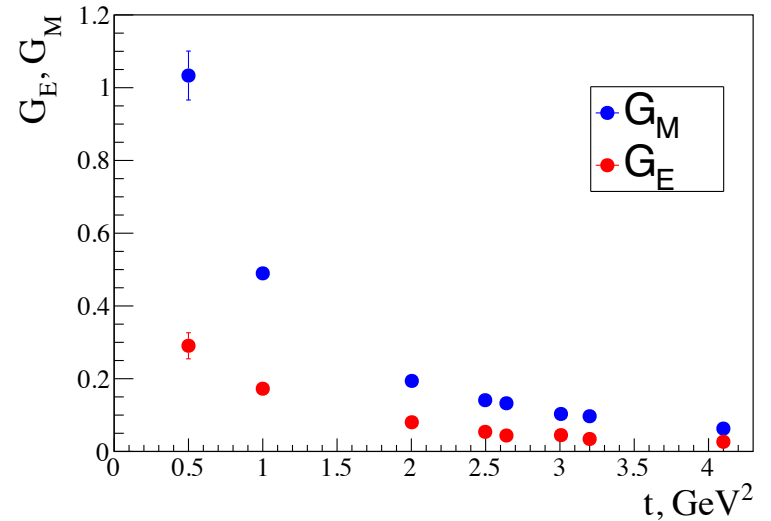

$$\sigma_R(E_\gamma, t) = \frac{d\sigma}{d\Omega} / \left( \frac{d\sigma}{d\Omega} \right)_M \epsilon(E_\gamma, t)(1 + \tau(t)) = \epsilon(E_\gamma, t) G_E^2(t) + \tau(t) G_M^2(t)$$

# Threshold $J/\psi$ photoproduction - "Rosenbluth" separation

$G_0(t)$  and  $G_2(t)$  extraction

$$\sigma_r(E_\gamma, t) = \frac{d\sigma}{dt} \frac{\xi^2(E_\gamma, t)}{F(E_\gamma)} = \xi^{-2}(E_\gamma, t) G_0(t) + G_2(t)$$

- GlueX 11.4 GeV
- GlueX 10.36 GeV
- GlueX 9.28 GeV

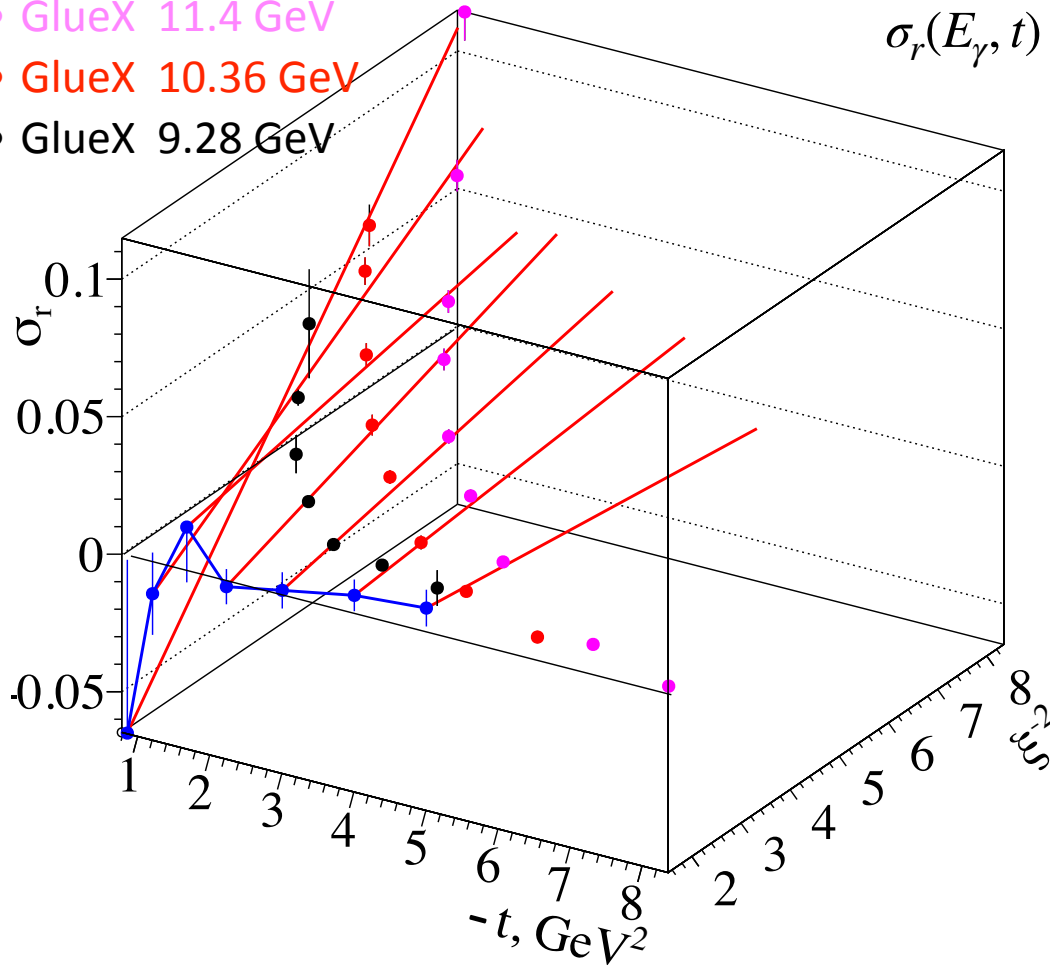

$$G_0(t) = \left( \mathcal{A}_g^{(2)}(t) \right)^2 - \frac{t}{4m^2} \left( \mathcal{B}_g^{(2)}(t) \right)^2 > 0$$

Therefore  $d\sigma/dt(E, t)$  at fixed  $t$ , must increase with energy, consistent with the data!

# Gluon Form Factors - energy independence

$\gamma p \rightarrow J/\psi p$

Energy independence of the  $G_0(t)$  FF function (within errors)

No theory/lattice constraints used,  
No theoretical assumptions,

GPD approach used as a guidance:

$$\sigma_r(E_\gamma, t) = \frac{d\sigma}{dt} \frac{\xi^2(E_\gamma, t)}{F(E_\gamma)} = \xi^{-2}(E_\gamma, t) G_0(t) + G_2(t)$$

$$\xi(E_\gamma, t) = \frac{M_{J/\psi}^2 - t}{4E_\gamma m - M_{J/\psi}^2 + t}$$

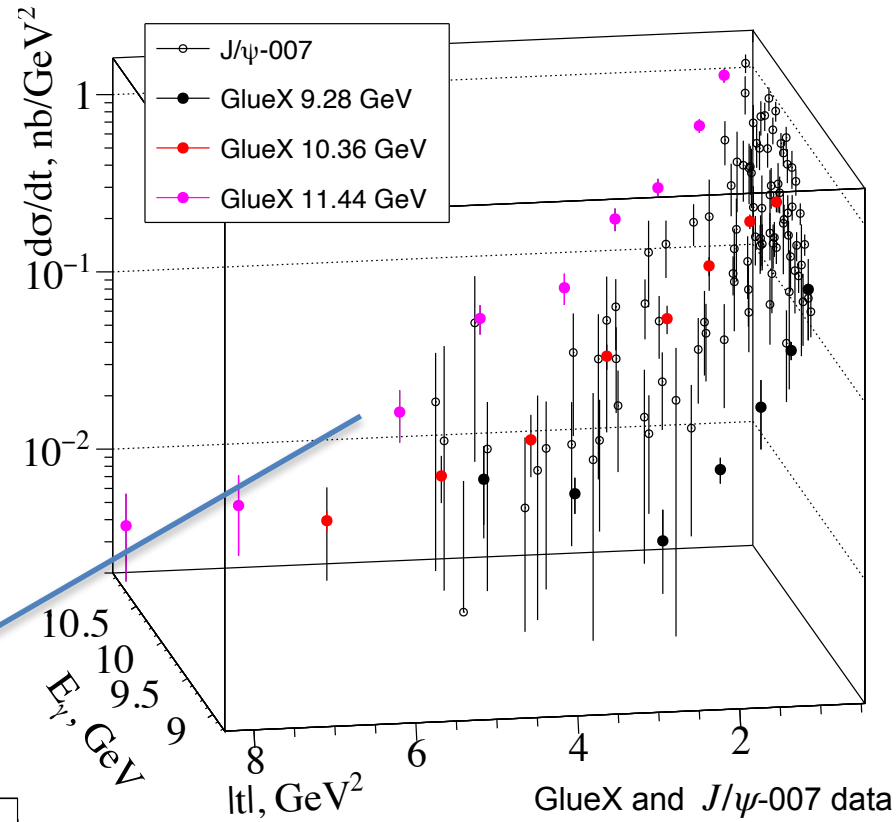

GlueX and  $J/\psi$ -007 data  
*Phys.Rev.C 108 (2023)*  
*Nature 615 (2023)*

Fit with  $\frac{G_0(0)}{(1 - t/m_{G_0}^2)^4}$

LP and E.Chudakov  
*Phys. Rev. D 112, 052009 (2025)*

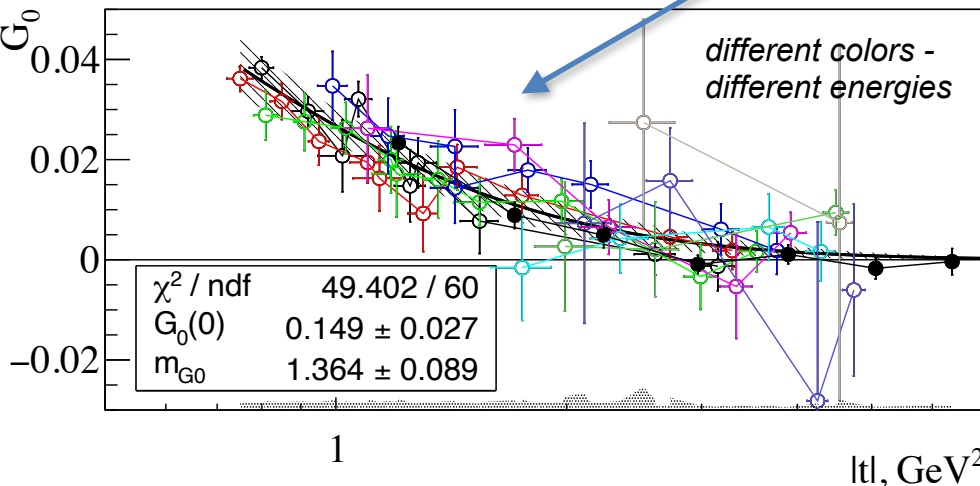

# Relation to Gluon Gravitational Form Factors

now using theory

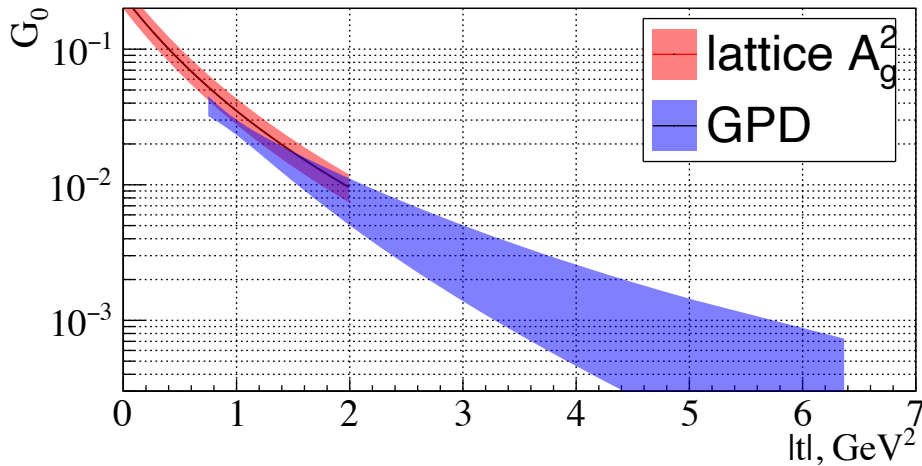

Features in data consistent with the GPD model:

- $d\sigma/dt(E_\gamma, t \rightarrow \text{fixed})$  increases with energy
- $G(t)$  form factor functions are energy independent (within the experimental errors)
- In leading-term approximation (and neglecting  $B_g$ ):

$$G_0(t) = A_g^2(t) \text{ and}$$

$$G_0(t) + G_2(t) = 8C_g(t)A_g(t)$$

→ agreement with lattice

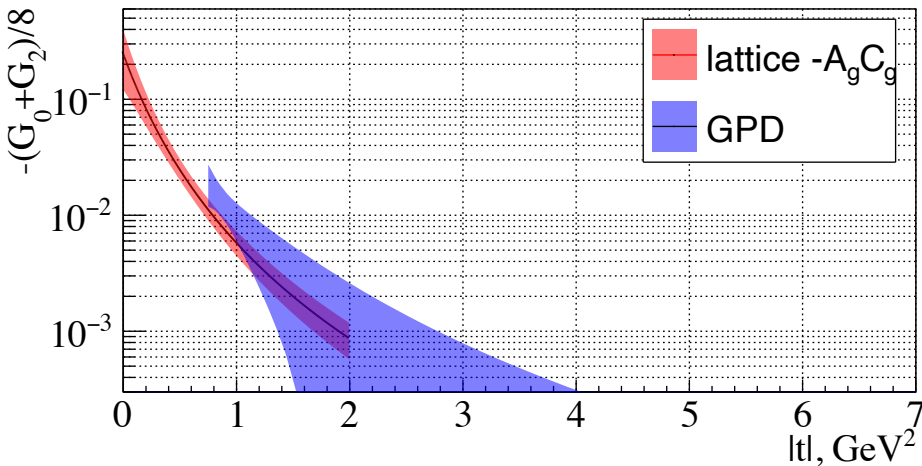

# Other reaction mechanisms: open-charm, resonance

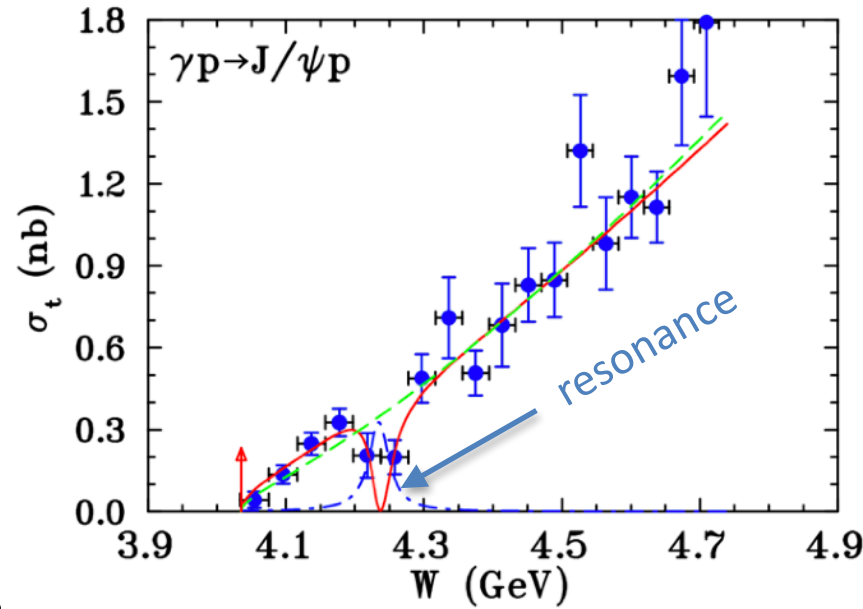
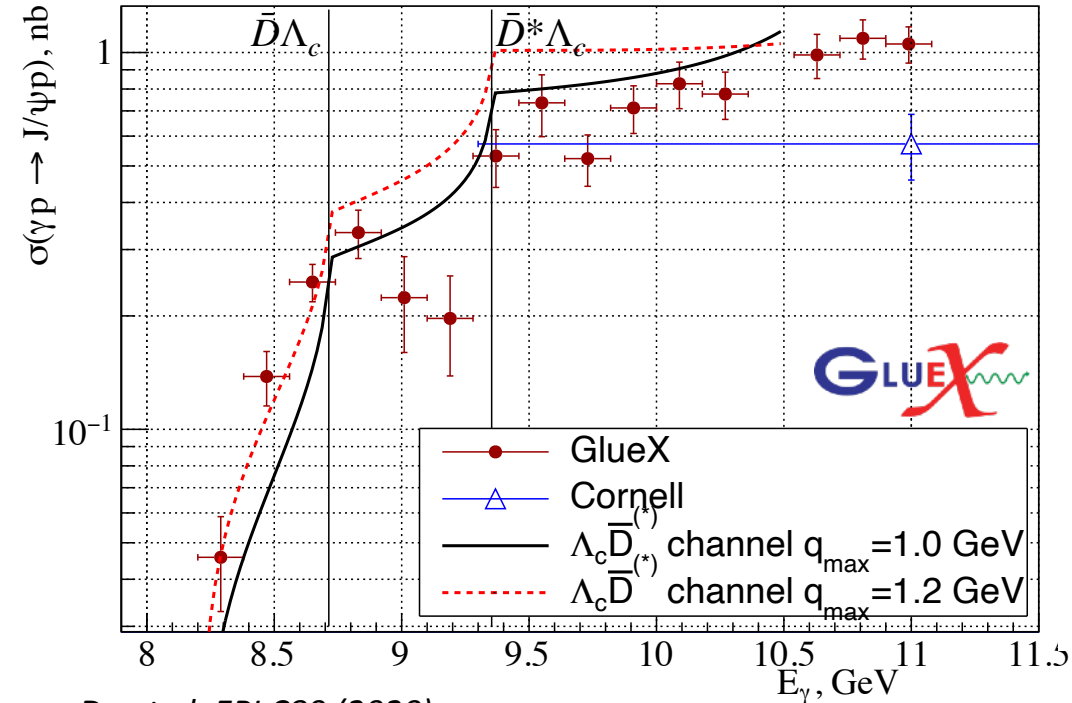

Strakovsky et al. PRC 108 (2023)

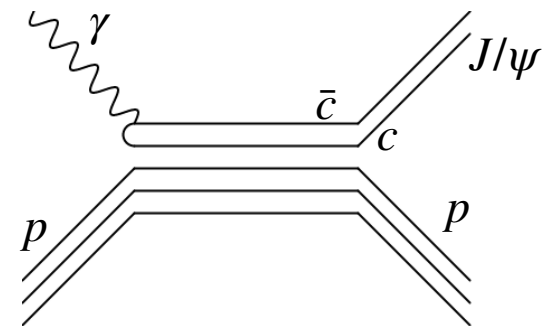
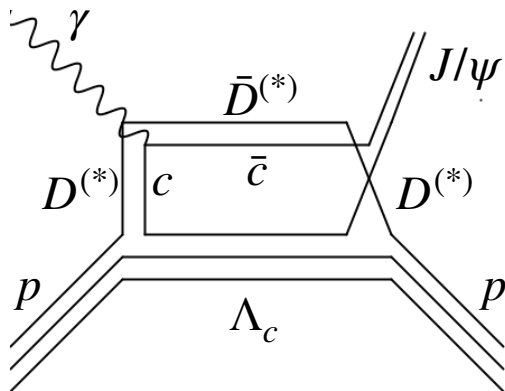

# C-even charmonium states at threshold with GlueX

First ever evidence for photoproduction of C-even charmonium

$$1^{--} \rightarrow 1(2)^{++}$$

$$\gamma p \rightarrow \chi_c p \rightarrow (J/\psi \gamma) p \rightarrow (e^+ e^- \gamma) p$$

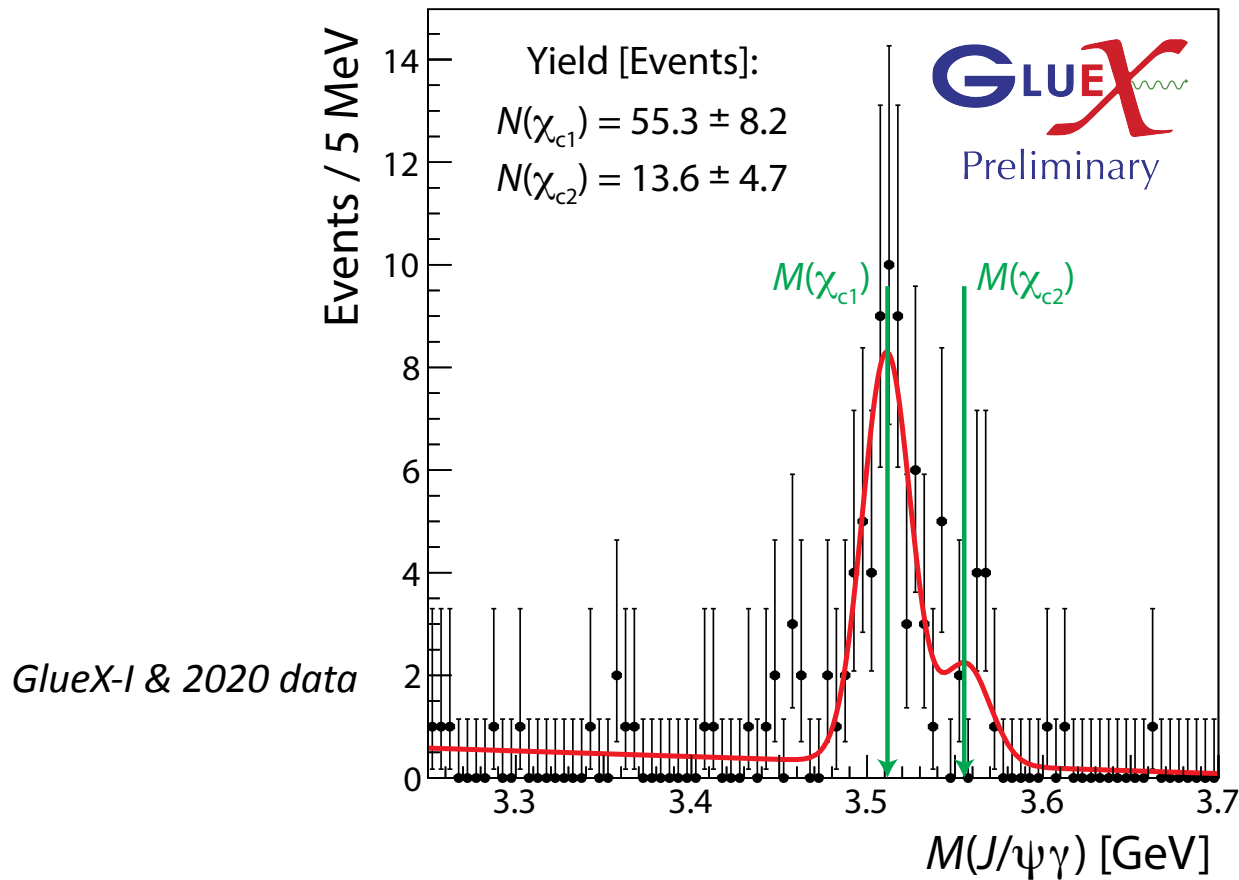

- $\chi_{c1}(3511)$  and  $\chi_{c2}(3556)$ ,  $1^{++}$  and  $2^{++}$  ( $1P$ ),  $E_\gamma^{thr} = 10.1$  GeV

# C-even charmonium states at threshold with GlueX

- Dramatic difference:  $\chi_c$  distribution in  $(E_\gamma, t)$  vs  $J/\psi$

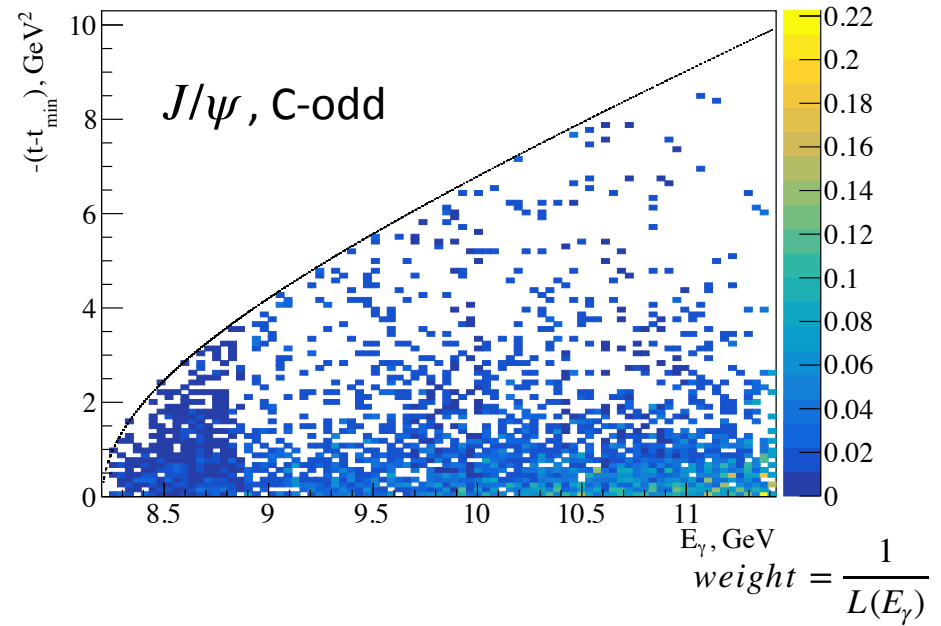
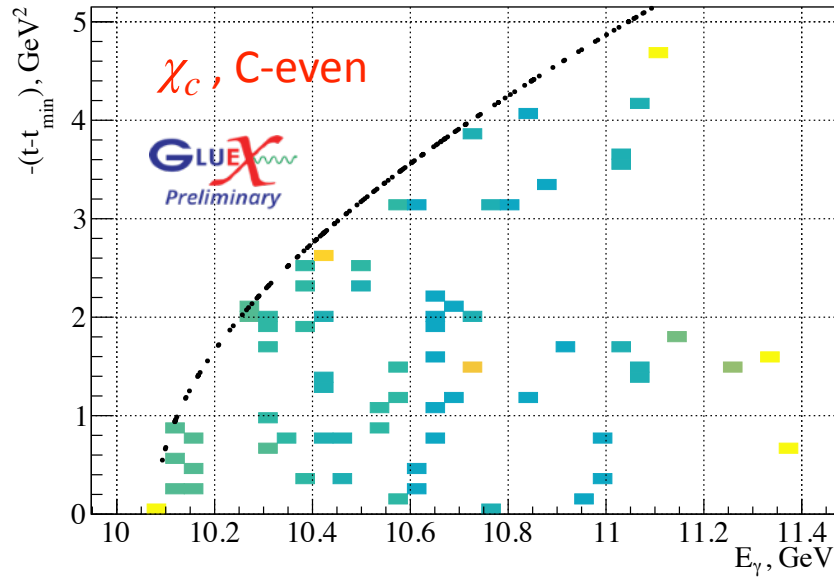

# t-channel production - perturbative calculations

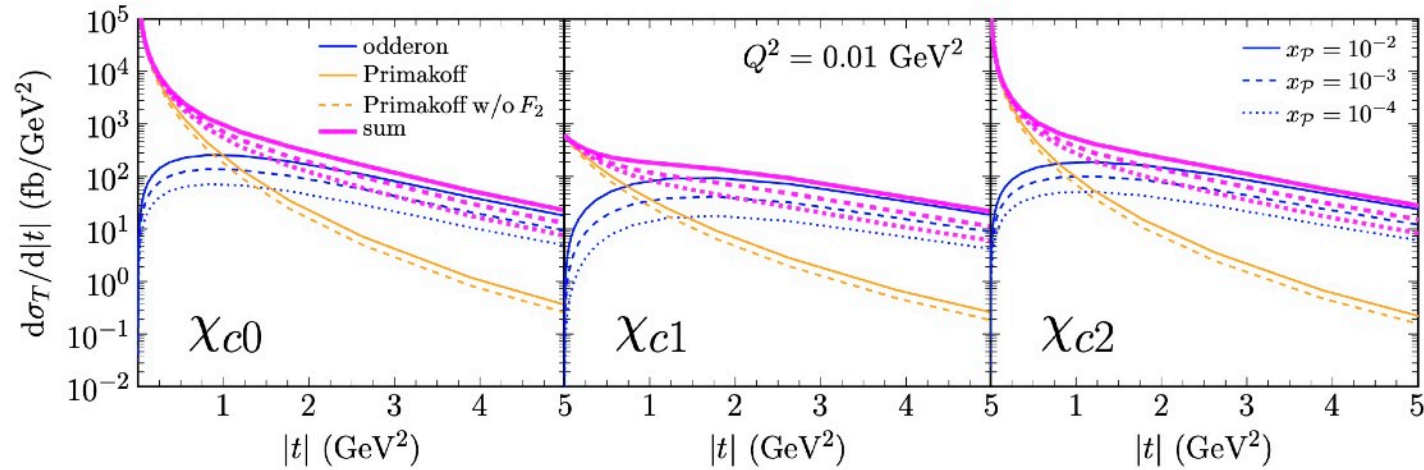

*Benic, Dumitru, Kaushik, Motyka, Stebel, PRD 110 (2024) - perturbative calculations (high energies)*

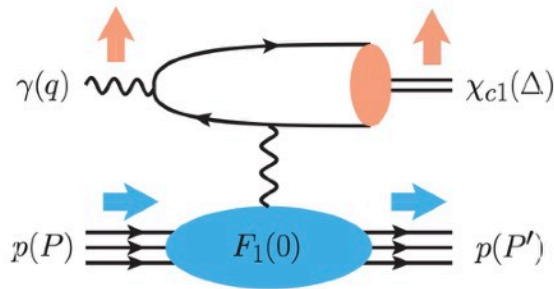

- **Primakoff** - suppressed for  $\chi_{c1}$  due to Landau-Yang theorem:  
 $\chi_{c1}(J = 1) \rightarrow \gamma\gamma$  suppressed for  $t \rightarrow 0$

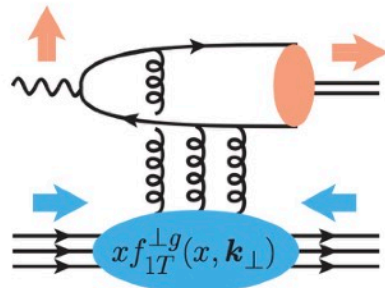

- **Odderon (odd-parity Pomeron) 3g exchange - suppressed**, still dominates at higher  $|t|$  due to  $n_s = 0$  ( $n_s = 2$  for Primakoff)

# t-channel production - vector meson exchange

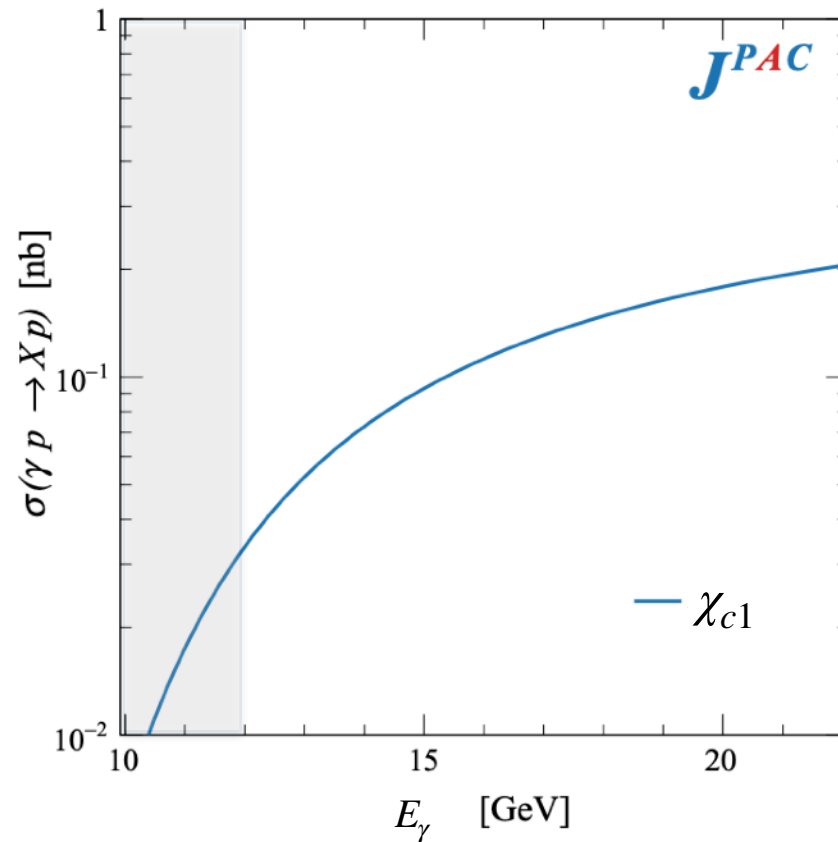
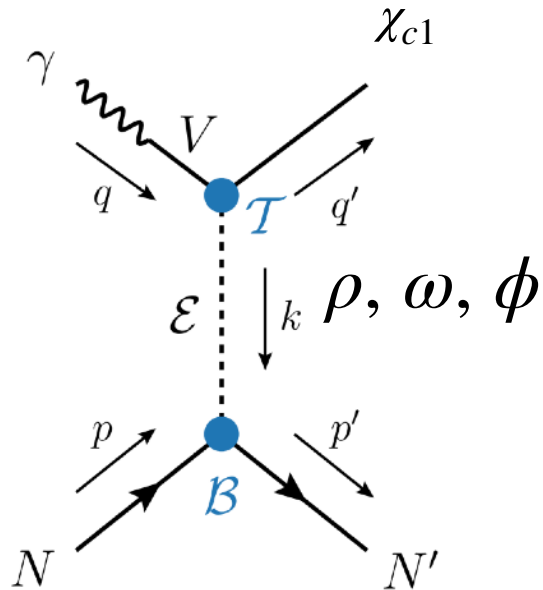

JPAC, PRD 102 (2020)

- Low energies - non-perturbative approach, vector meson exchange
- $\chi_c \rightarrow \gamma V(\rho, \omega, \phi)$  is suppressed

# s-channel mechanisms

- $t$ -channel is suppressed (requires C-odd exchange), allows us to study other possible mechanisms that may dominate:

S-channel exchange of  $5q$

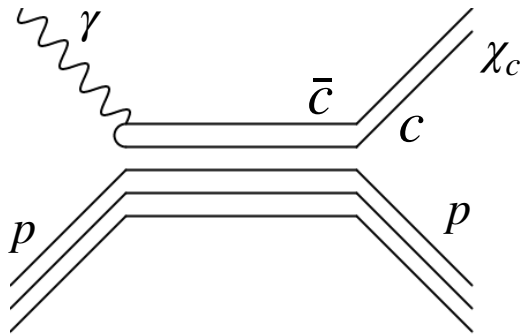

Open-charm exchange

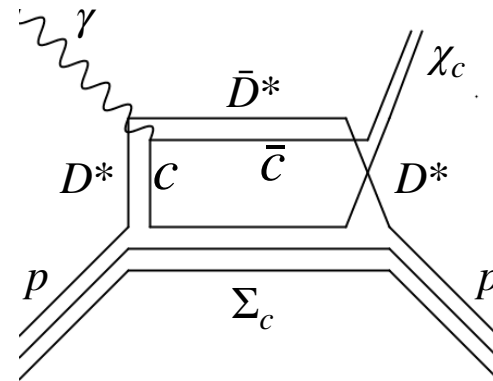

# GlueX phase III - charm physics

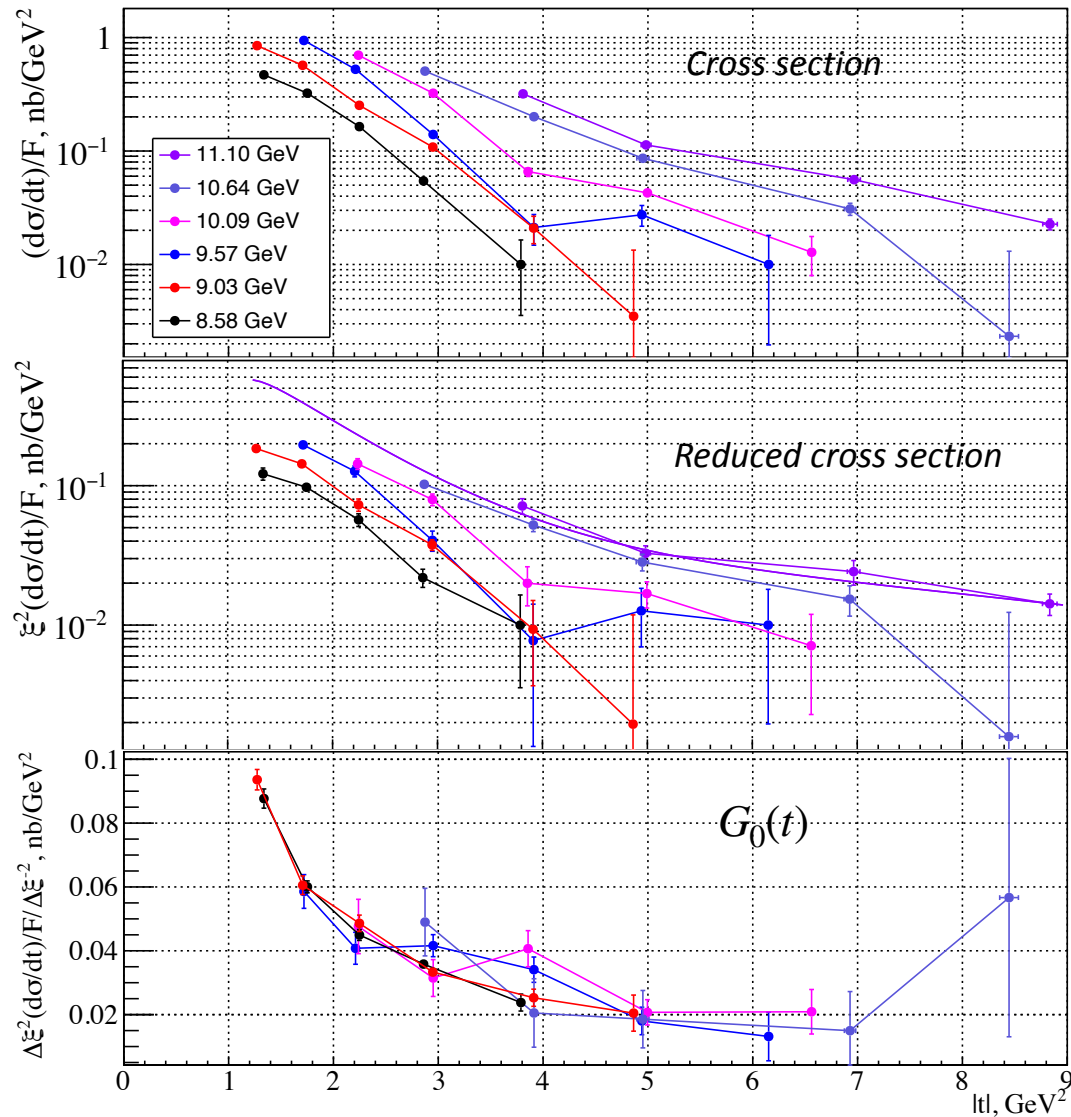

- GlueX III - planned for 2027/2028 running with doubled intensity
- Factor of four increase in  $J/\psi$  statistics - total of about 18k events
- Expect  $\sim 450 \chi_c$  and 200  $\psi(2S)$  assuming nominal (12 GeV) beam energy
- Significant reduction of pion background and higher purity of  $J/\psi$  sample using Transition Radiation Detector

# Pion suppression with new Transition Radiation Detector

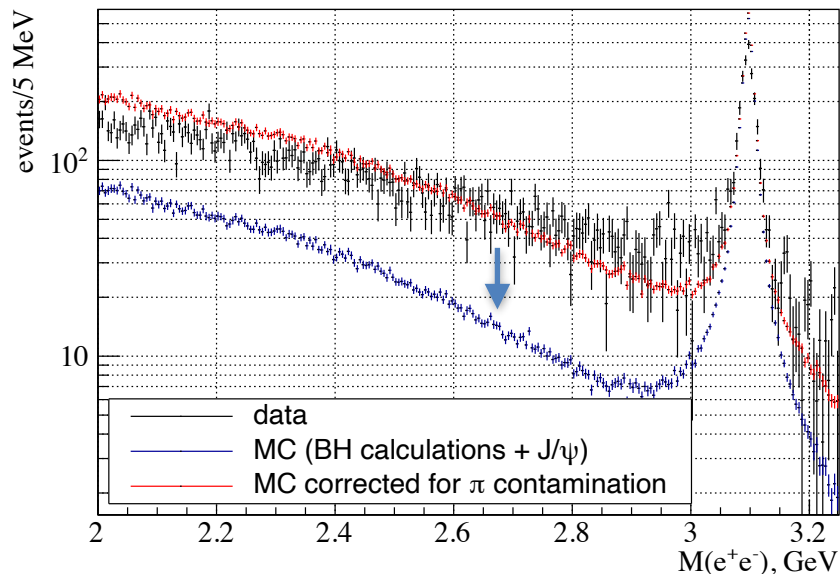
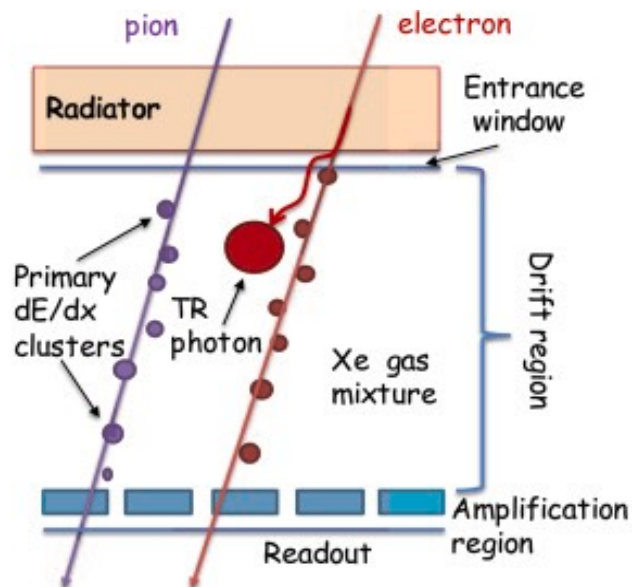

“Development and Characterization of MPGD-based Transition Radiation Detectors” L.Kasper et al., [NIMA](#) (2026)

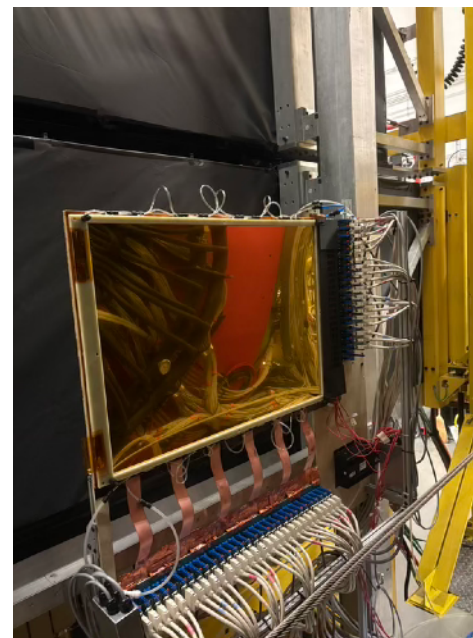
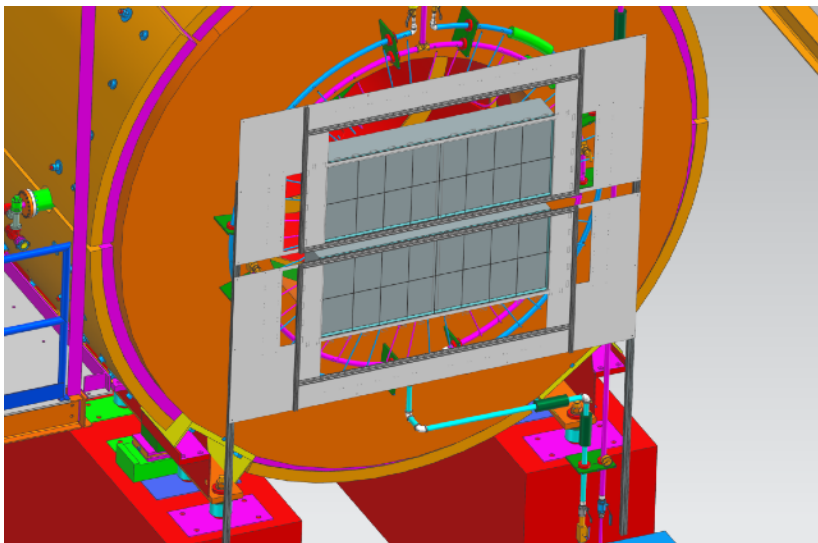

# Threshold charmonium photoproduction at JLab22 with GlueX

GlueX uses polarized photon beam from coherent Bremsstrahlung

Taking advantage of increased end-point (electron beam energy):

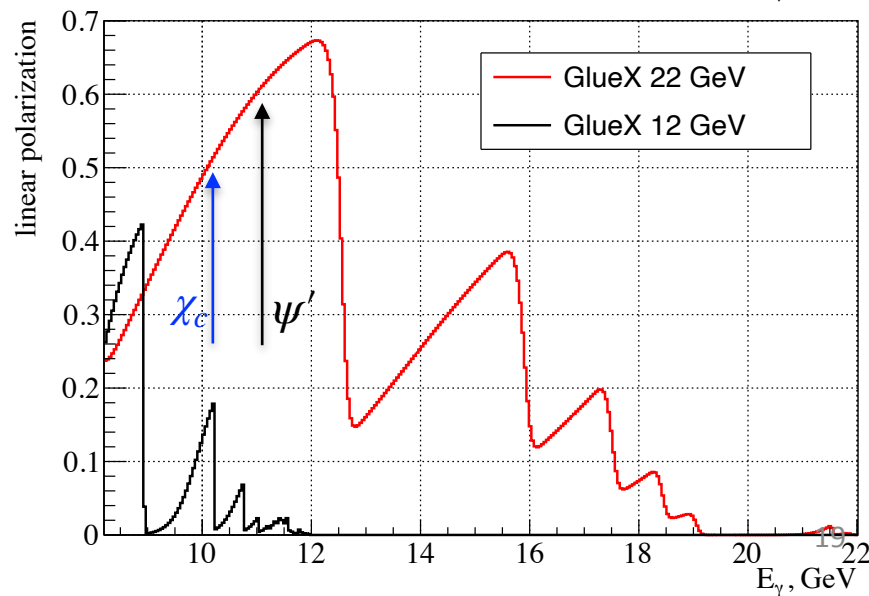
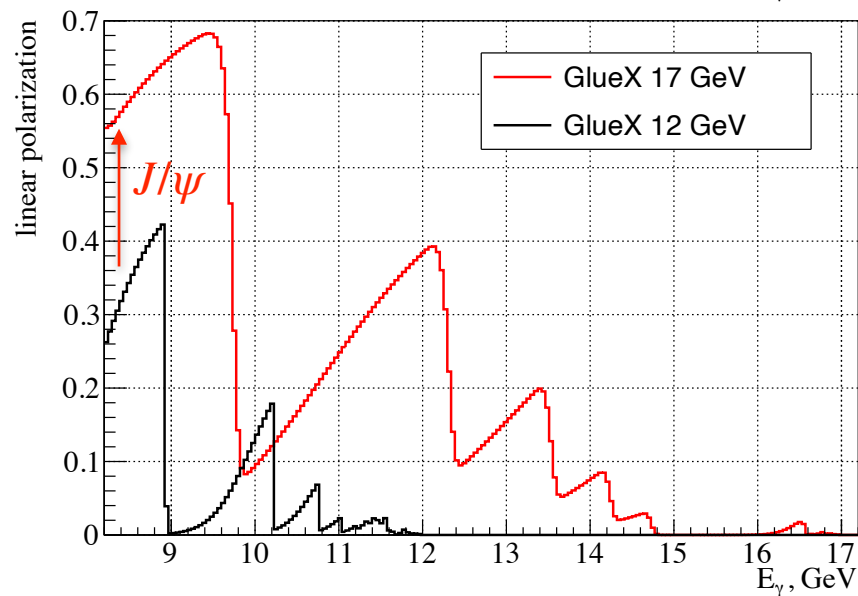
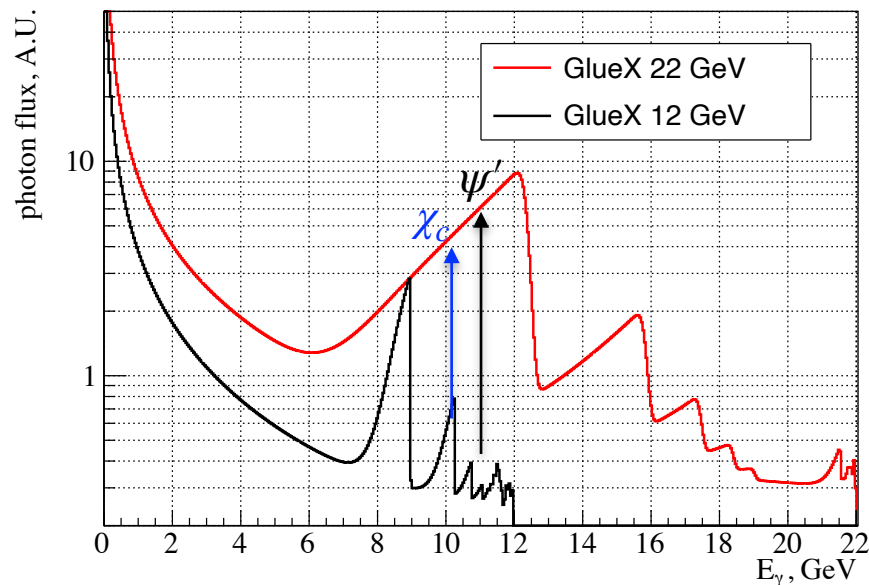
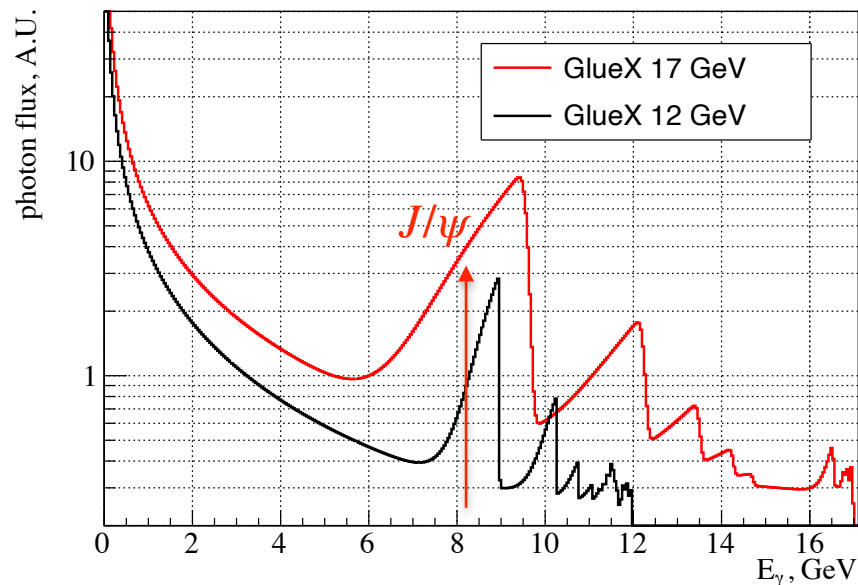

# Polarization measurements at JLab22 with GlueX

$\gamma p \rightarrow J/\psi p \rightarrow e^+e^- p$

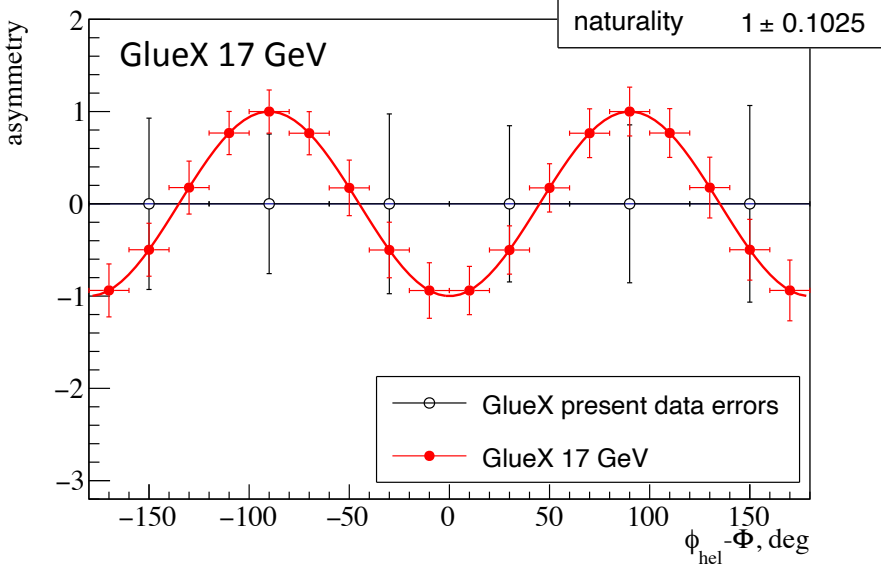

$\gamma p \rightarrow J/\psi p \rightarrow e^+e^- p$

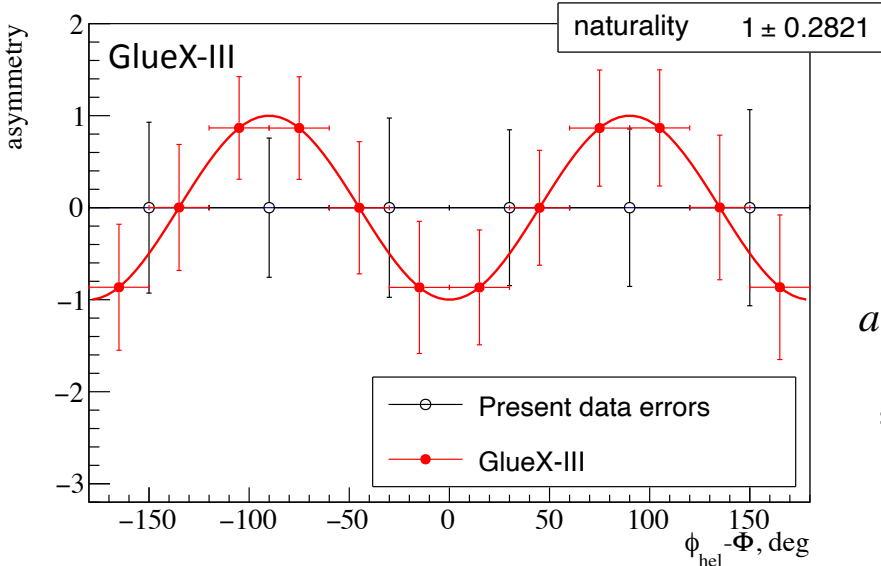

$$\text{naturality} \times (-1)^J = P$$

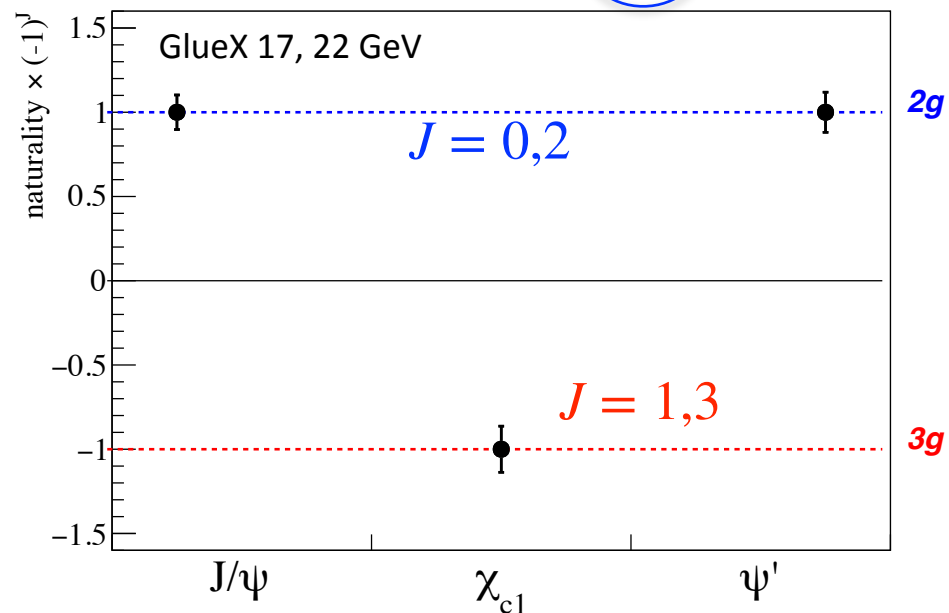

$$\begin{aligned} \text{asymmetry} &= \frac{2}{P_\gamma} \frac{Y_{J/\psi}(0) - Y_{J/\psi}(90)}{Y_{J/\psi}(0) + Y_{J/\psi}(90)} = \\ &= -(\rho_{1-1}^1 - \text{Im}\rho_{1-1}^2) \cos[2(\phi_{hel} - \Phi)] \end{aligned}$$

$$\text{naturality} = (-1)^J P$$

# Summary

- Thanks to JLab 12 GeV upgrade - comeback of charmonium threshold measurements - a tool to study gluonic content of nucleon
- “Rosenbluth” (kinematic) separation of the  $J/\psi$  near-threshold photo-production consistent with assumption of FFs independent of energy - no theoretical assumptions
- Using GPD theoretical approach, extracted gluon GFFs on the same scale as lattice results
- First observation of charmonium photoproduction with opposite-to-photon parities - allows studying contributions other than  $t$ -channel ones
- Future of charmonium measurements with GlueX
  - GlueX III - significant increase in statistics and purity (pion suppression with new Transition Radiation Detector)
  - CEBAF energy upgrade - adds new dimensions to these studies: higher-mass charmonia, precise polarization measurements

# Back-ups

# Phenomenological approach: JPAC results

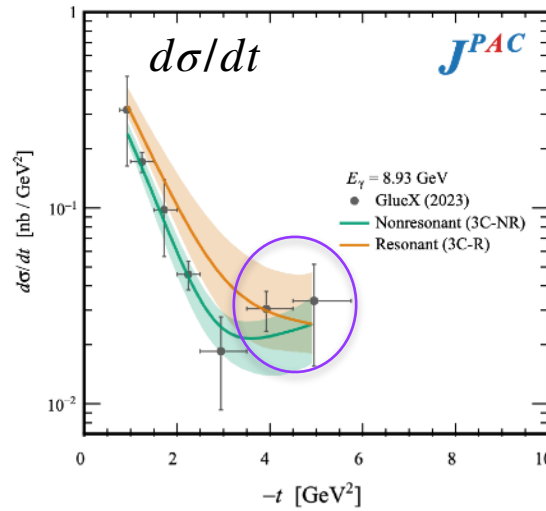
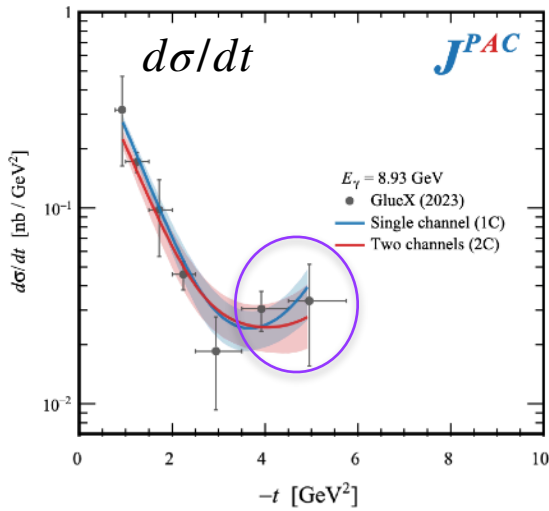
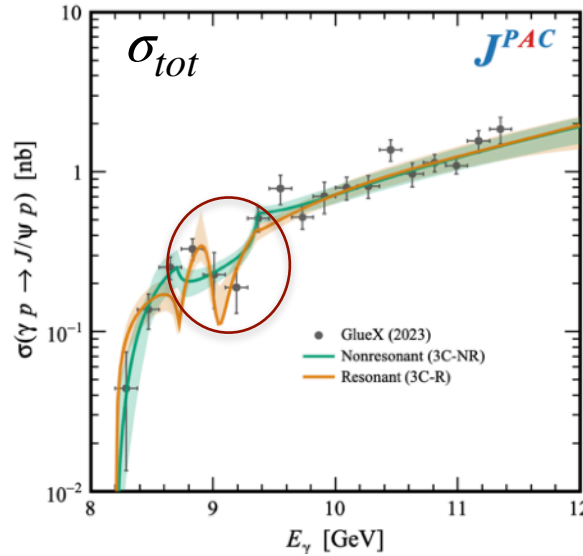
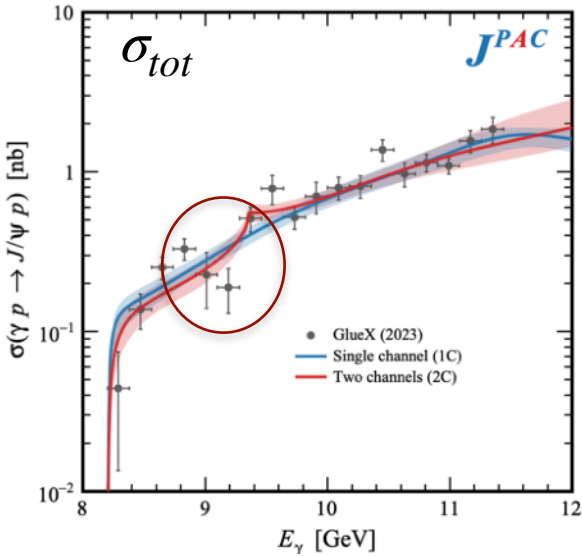

Phenomenological model based on s-channel PW expansion ( $l \leq 3$ ):

- (1C)  $J/\psi p$  interaction
- (2C)  $J/\psi p$  and  $\bar{D}^* \Lambda_C$
- (3C-NR)  $J/\psi p$ ,  $\bar{D} \Lambda_C$ ,  $\bar{D}^* \Lambda_C$  (non-resonant solution)
- (3C-NR)  $J/\psi p$ ,  $\bar{D} \Lambda_C$ ,  $\bar{D}^* \Lambda_C$  (resonant solution)

No stat. significant preference:

- 9 GeV structure requires sizable contribution from open charm
- Severe violation of VMD and factorization not excluded
- s-channel resonance not excluded
- t-enhancement indicates s-channel contribution: due to proximity to threshold or open-charm exchange

JPAC Phys.Rev.D 108 (2023)

Global fit of both Hall C & D  $d\sigma/dt(t)$  and Hall D  $\sigma_{tot}(E_\gamma)$

# Recent results from CLAS12 and $J/\psi$ -007

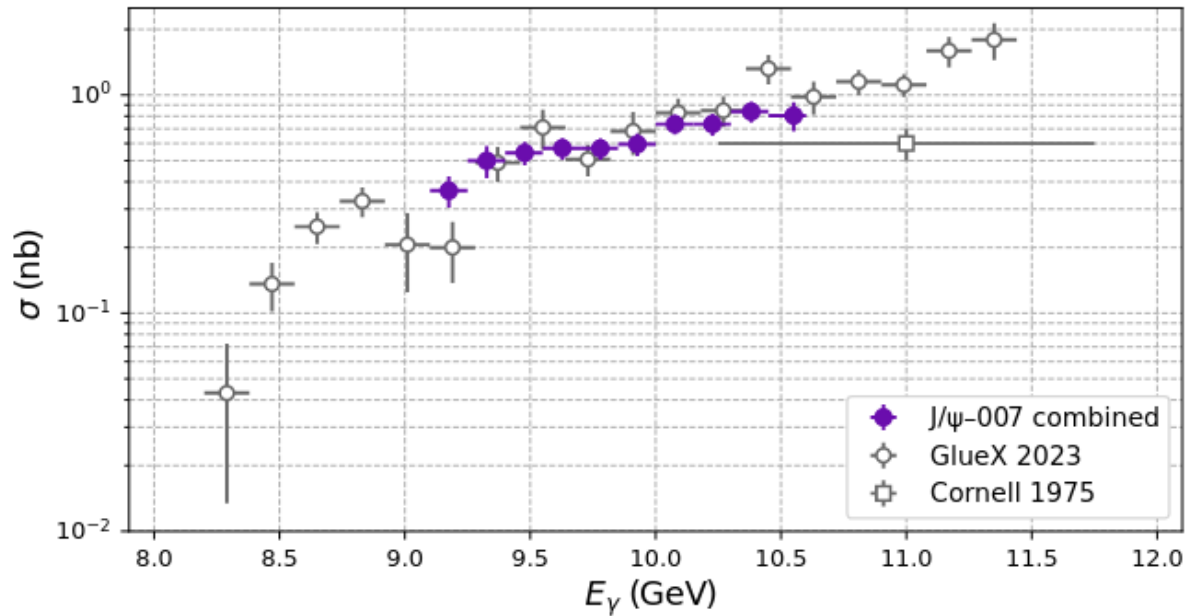

- No obvious dip seen in recent CLAS12 and  $J/\psi$ -007 (including muon channel) data
- Still, statistically compatible with GlueX results

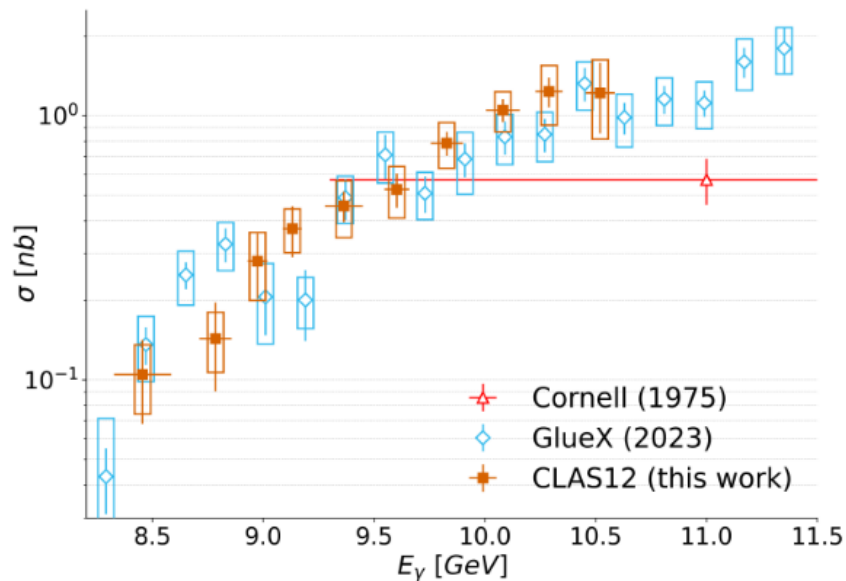

# Threshold $J/\psi$ photoproduction - the data

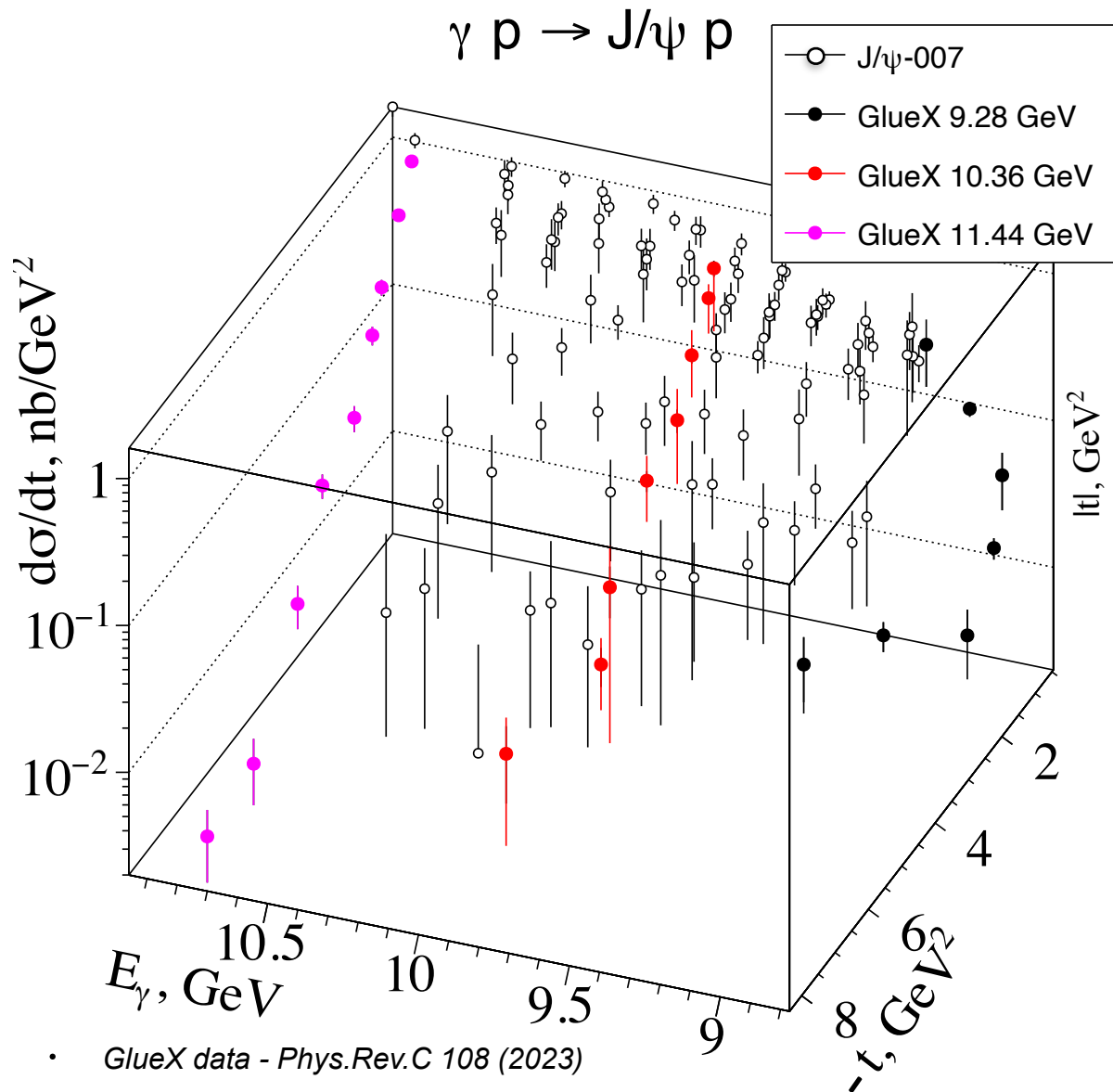

- GlueX data - *Phys.Rev.C* 108 (2023)
- $J/\psi$ -007 data - *Nature* 615 (2023)

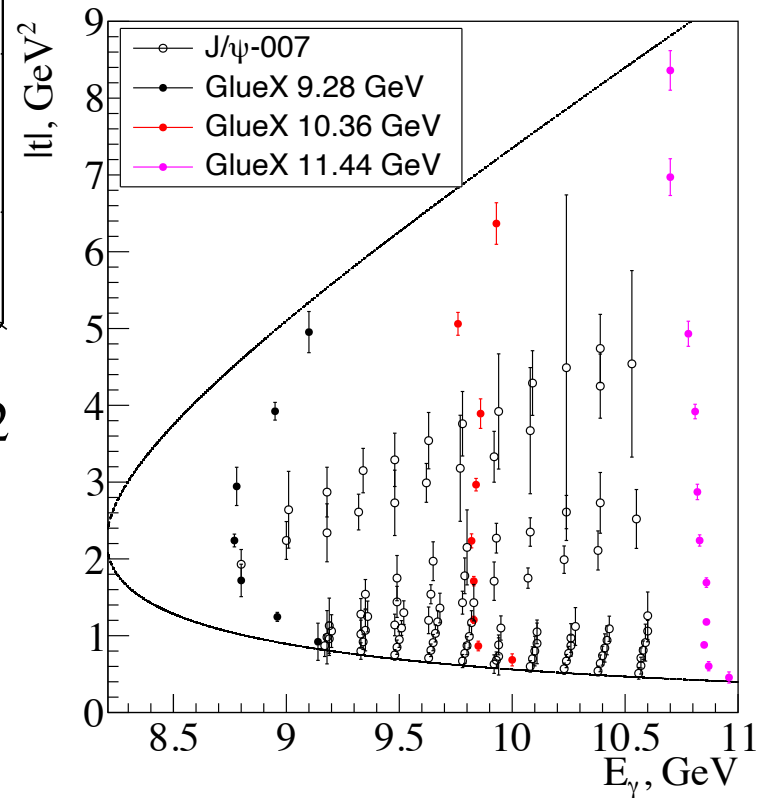

# Threshold charmonium photoproduction - GPD and holographic approaches

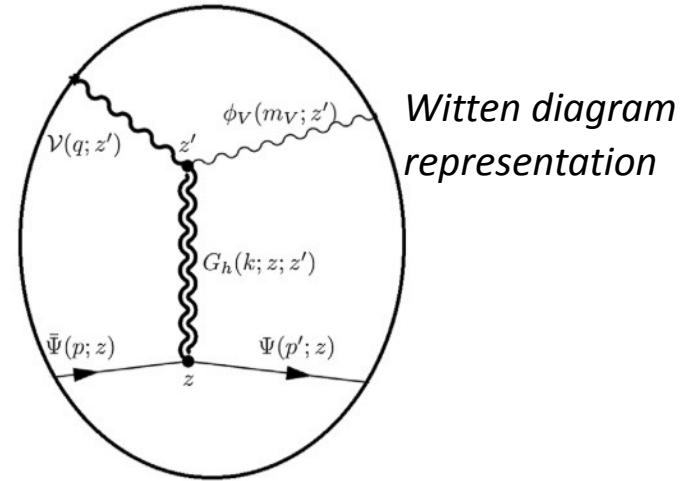
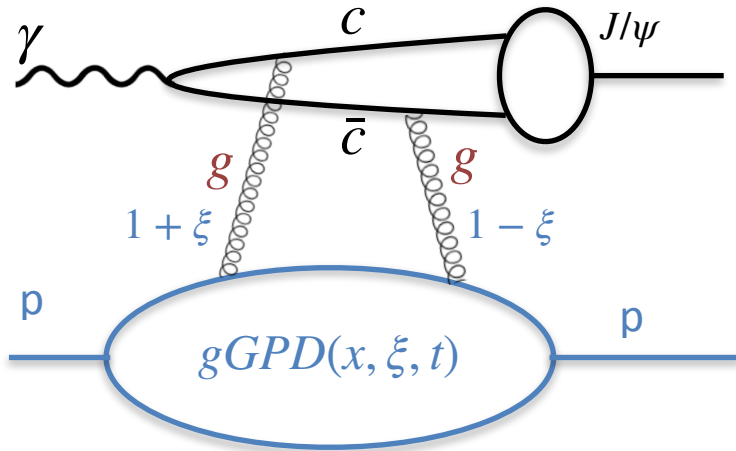

$$\left(\frac{d\sigma}{dt}\right)_{\gamma p \rightarrow J/\psi p} = F(E_\gamma) \xi^{-4} [G_0(t) + \xi^2 G_2(t)] + \dots$$

$$G_0(t) = \left(\mathcal{A}_g^{(2)}(t)\right)^2 - \frac{t}{4m^2} \left(\mathcal{B}_g^{(2)}(t)\right)^2$$

$$G_2(t) = 2\mathcal{A}_g^{(2)}(t)\mathcal{C}_g(t) + 2\frac{t}{4m^2}\mathcal{B}_g^{(2)}(t)\mathcal{C}_g(t) - \left(\mathcal{A}_g^{(2)}(t) + \mathcal{B}_g^{(2)}(t)\right)^2$$

$$\mathcal{A}_g^{(2)}(t) = A_g(t)$$

$$\mathcal{B}_g^{(2)}(t) = B_g(t)$$

$$\mathcal{C}_g(t) = 4C_g(t)$$

$$\xi = \frac{M_{J/\psi}^2 - t}{2(s - m^2) - M_{J/\psi}^2 + t}$$

leading moments for high  $\xi$  values

$$\left(\frac{d\sigma}{dt}\right)_{\gamma p \rightarrow J/\psi p} = N(E_\gamma) [H_0(t) + \eta^2 H_2(t)] + \dots$$

$$H_0(t) = A_g^2(t)$$

$$H_2(t) = 8A_g(t)C_g(t)$$

for large  $N_c$  and strong  $\alpha_s$

$$\eta = \frac{M_{J/\psi}^2}{2(s - m^2) - M_{J/\psi}^2 + t}$$

Holographic analysis by Mamo and Zahed PRD 106 (2022), PRD, PRD 101 (2020), Hatta and Yang PRD 98 (2018)

# Gluon Form Factors - energy independence - Holography

$$\gamma p \rightarrow J/\psi p$$

Energy independence of the  $H_0(t)$  FF function (within errors)

Using GlueX and  $J/\psi$ -007 data - different colors - different energies

No theory/lattice constraints used, No theoretical assumptions,

Holographic approach used as a guidance:

$$\sigma_r(E_\gamma, t) = \frac{d\sigma}{dt} \frac{\eta^{-2}(E_\gamma, t)}{F(E_\gamma)} = \eta^{-2}(E_\gamma, t) H_0(t) + H_2(t)$$

$$\eta(E_\gamma, t) = \frac{M_{J/\psi}^2}{4E_\gamma m - M_{J/\psi}^2 + t}$$

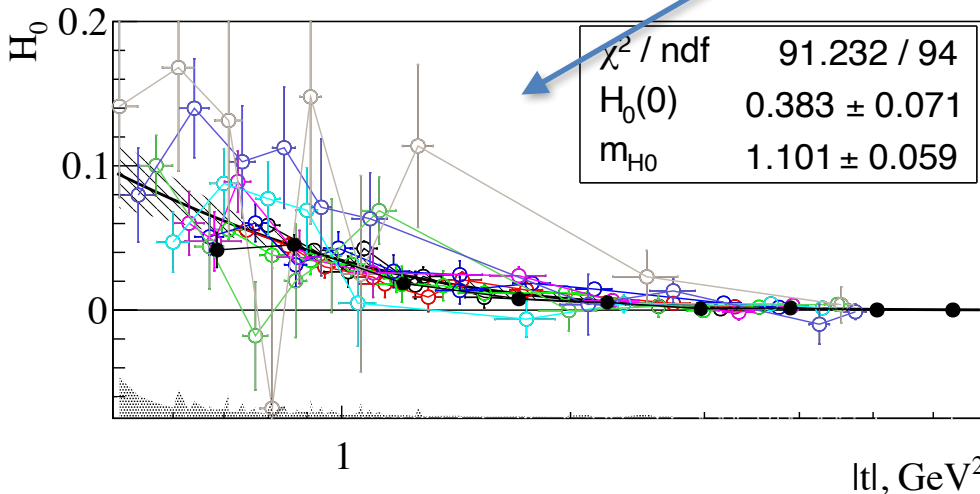
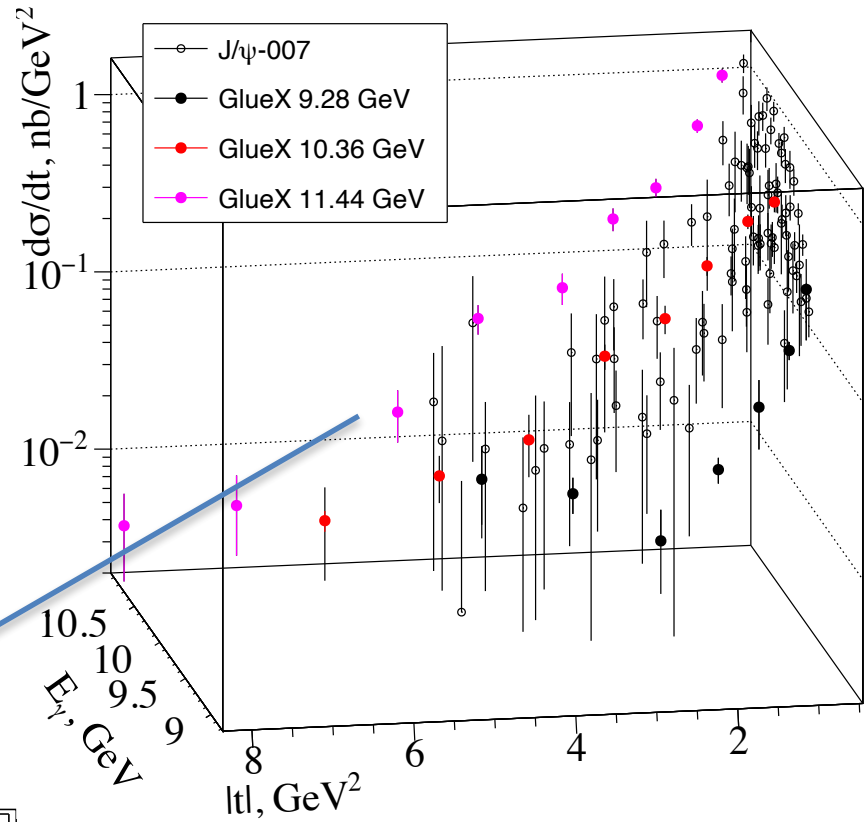

Fit with  $\frac{H_0(0)}{(1 - t/m_{H_0}^2)^4}$

LP and E.Chudakov  
Phys. Rev. D **112**, 052009 (2025)