



UNIVERSITY  
*of York*

# $K_L$ Flux Monitor

**Mikhail Bashkanov**

# $K_l$ flux monitor location



Be target

LH2/LD2 target

24 m

Flux Monitor

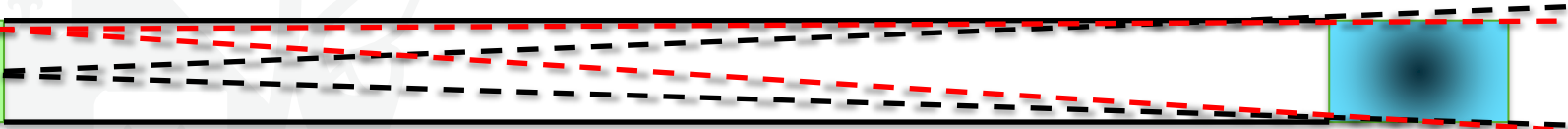

# $K_L$ decays



	Br, %
$K_L \rightarrow \pi^\pm e^\mp \nu_\mu$	40.55
$K_L \rightarrow \pi^\pm \mu^\mp \nu_\mu$	27.04
$K_L \rightarrow \pi^+ \pi^- \pi^0$	<b>12.54</b>
$K_L \rightarrow \pi^0 \pi^0 \pi^0$	19.52

- **~ 21% of kaons decays in flight**
- **Any decay with charged particles can be used**
- **$K_L \rightarrow \pi^+ \pi^- \pi^0$  has best systematics**

# KLF Flux monitor



UNIVERSITY  
*of York*

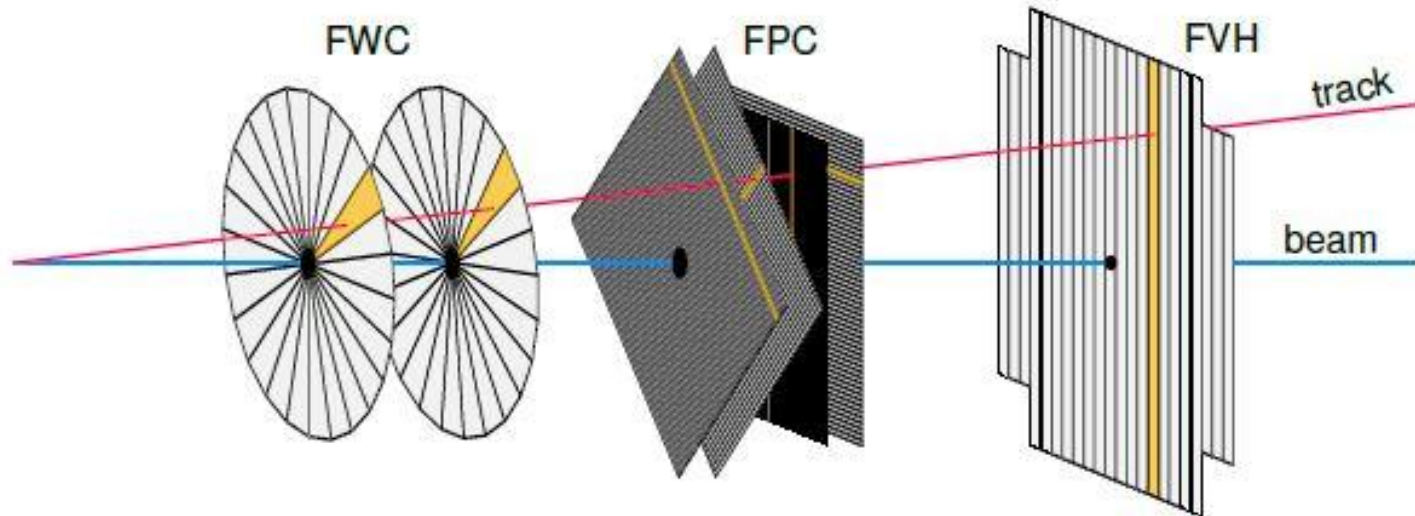

Used Wasa ToF system  
Used Wasa Trackers  
**NO** Magnet

- ⊕ Good performance
- ⊕ Cheap
- ⊗ Limited capabilities in rare kaon decay studies

# KLF Flux monitor

Tracker

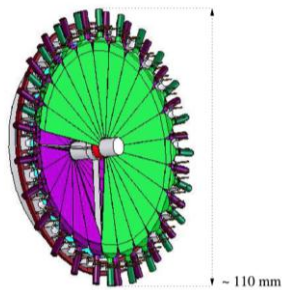

Start Detector  
(start time for TOF)

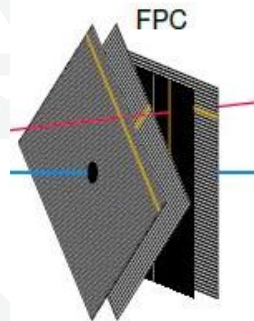

Coarse plastic tracker

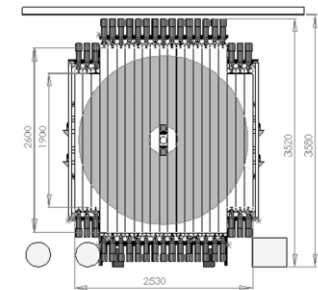
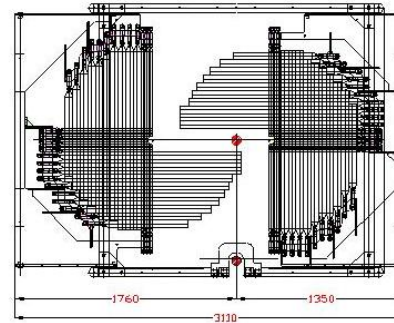

Stop Detector  
(stop time for TOF)

# $K_L$ monitoring

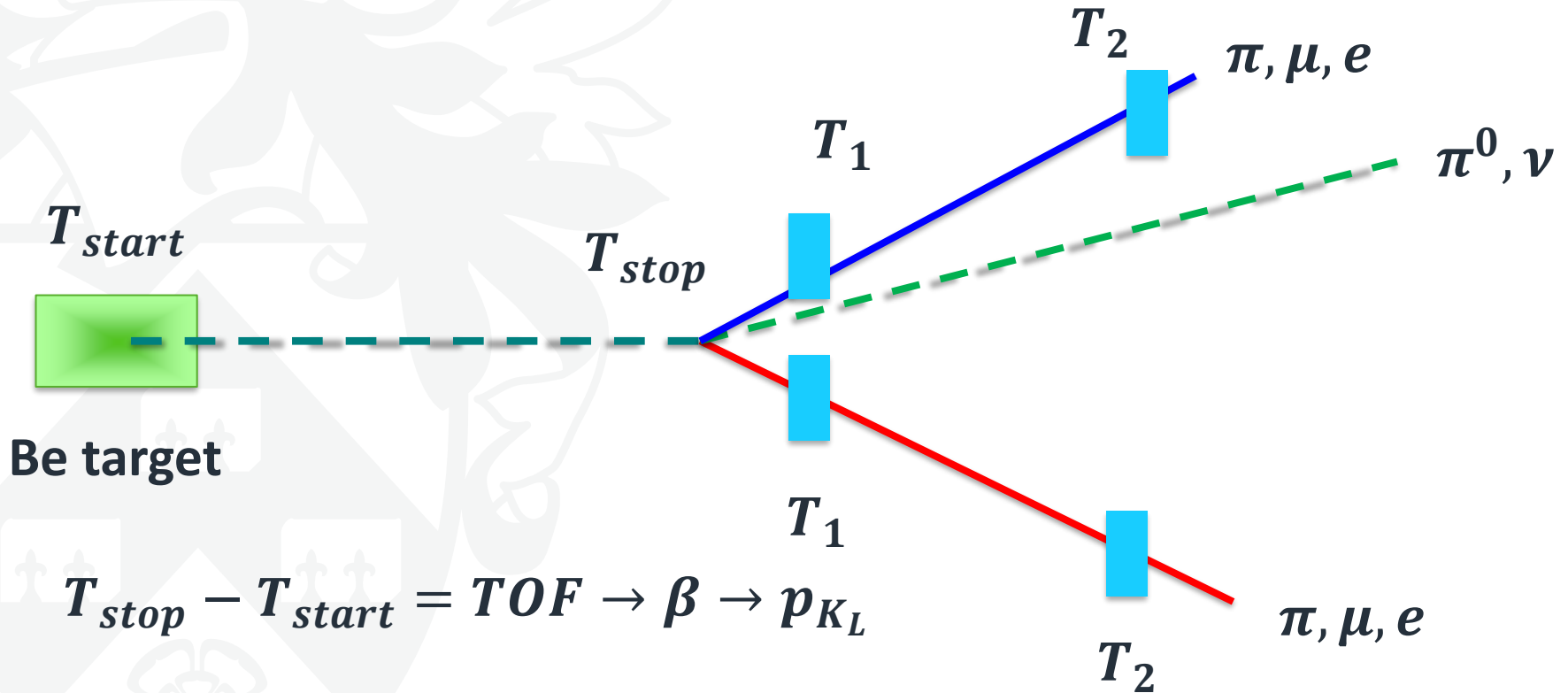

- All channels with 2 charged particles can be used
- No PID required



UNIVERSITY  
*of York*

# Detectors

# Detectors

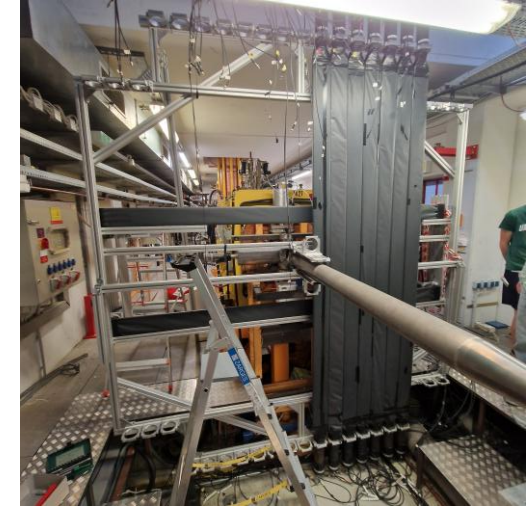
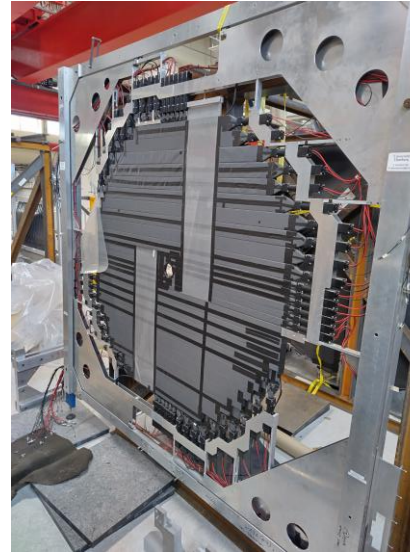
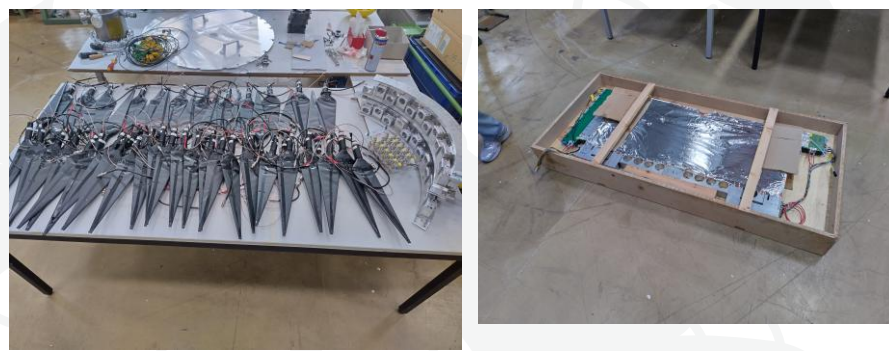

- Uninstalled
- Packed/boxed (transportation company)
- Transportation [paid Juelich]
- Paper work [ongoing]
  - {splitter modules letting contract}





UNIVERSITY  
*of York*

# Location and performance

# Location

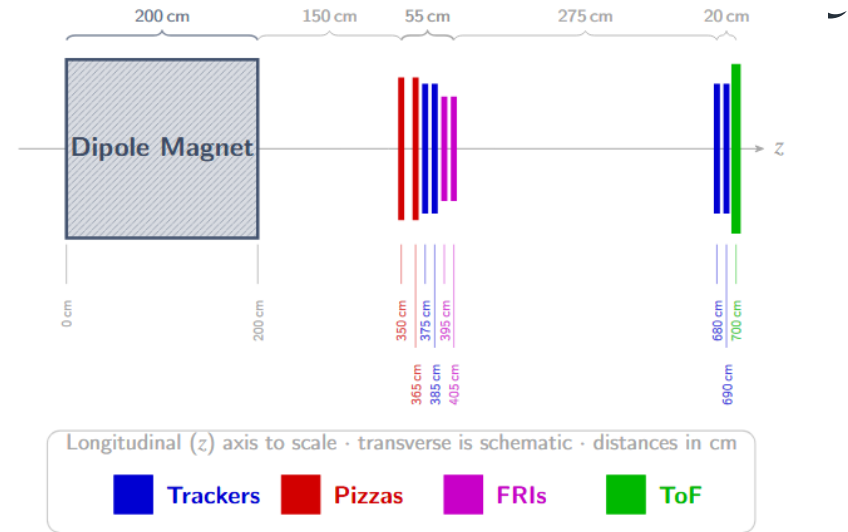
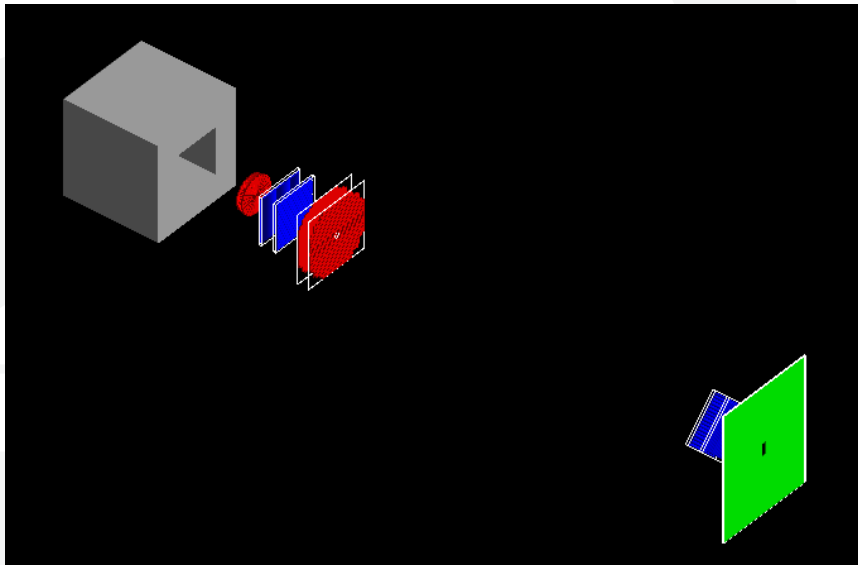

- TOF – as far away as possible -> longest time-of-flight
- Large decay volume
  - high stats 😊
  - Worse TOF resolution 😞
- Tracker backward position:
  - high level arm 😊
  - Scattering in the air 😞

# Acceptance

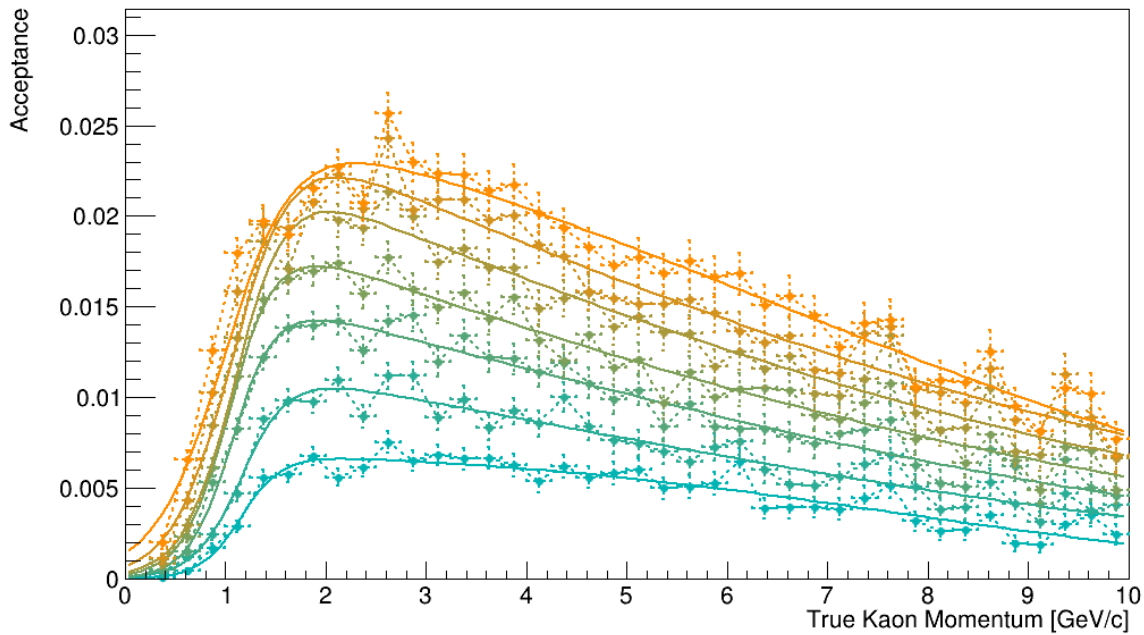

Detector Layouts

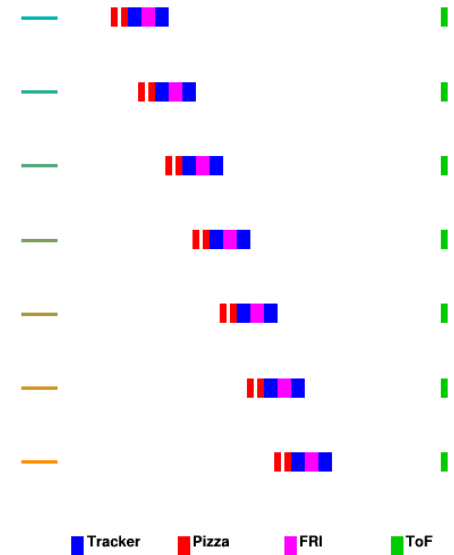

- Large decay volume
  - high stats 😊

# Resolution



Detector Layouts

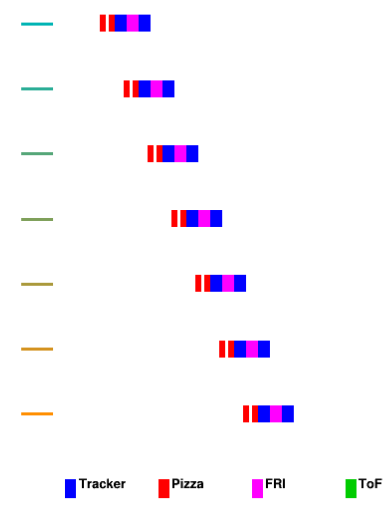
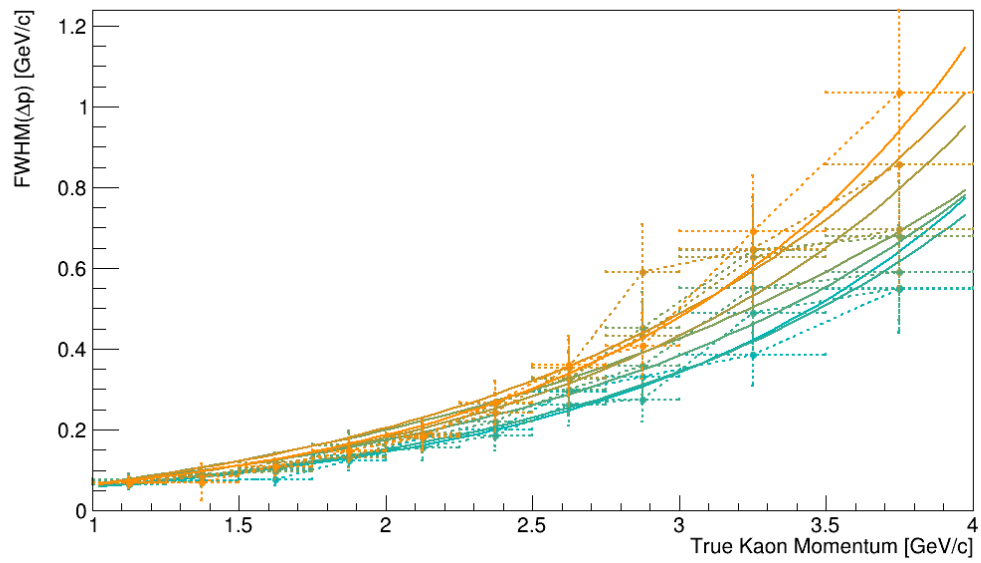

- Large decay volume
  - Smaller TOF distance
  - Worse TOF resolution 😞

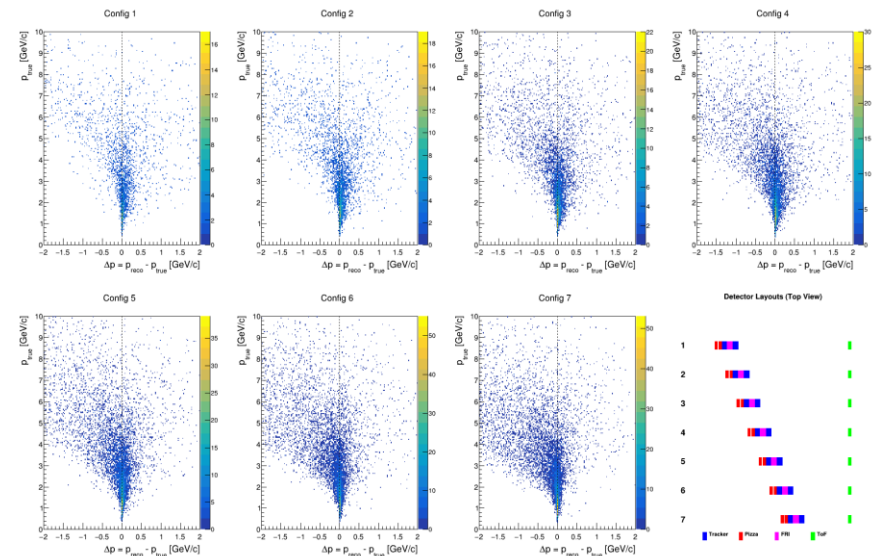

Mphys Ben Pink

# Figure of Merit

Mean FWHM vs Pizza Position

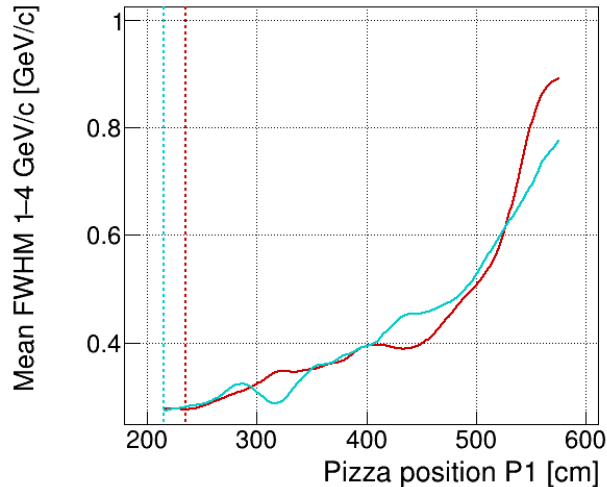

Best FWHM position  
**Upstream: 235 cm**  
**Downstream: 215 cm**

Peak Acceptance vs Pizza Position

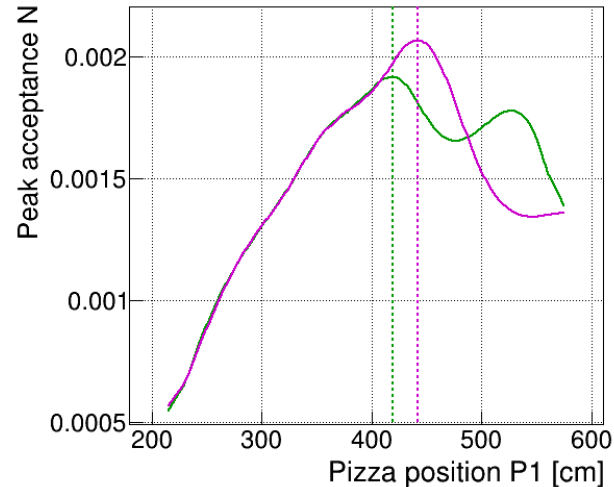

Best Acc. position  
**Upstream: 419 cm**  
**Downstream: 442 cm**

Figure of Merit vs Pizza Position

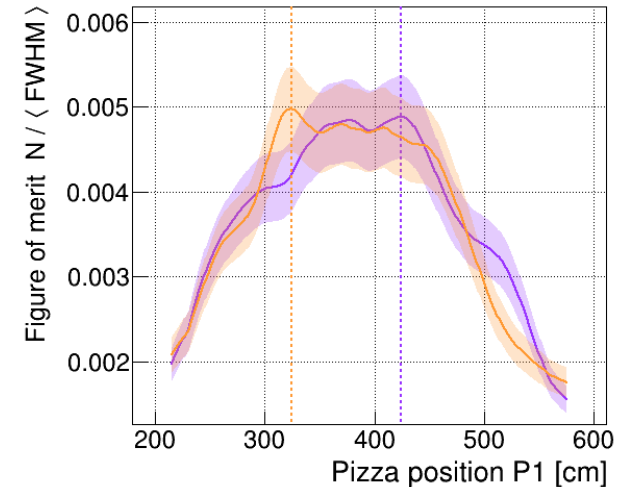

Best FOM position  
**Upstream: 424 cm**  
**Downstream: 324 cm**

- TOF as far away as possible
- From downstream edge of PS magnet to the Pizza 130-230cm

# Location

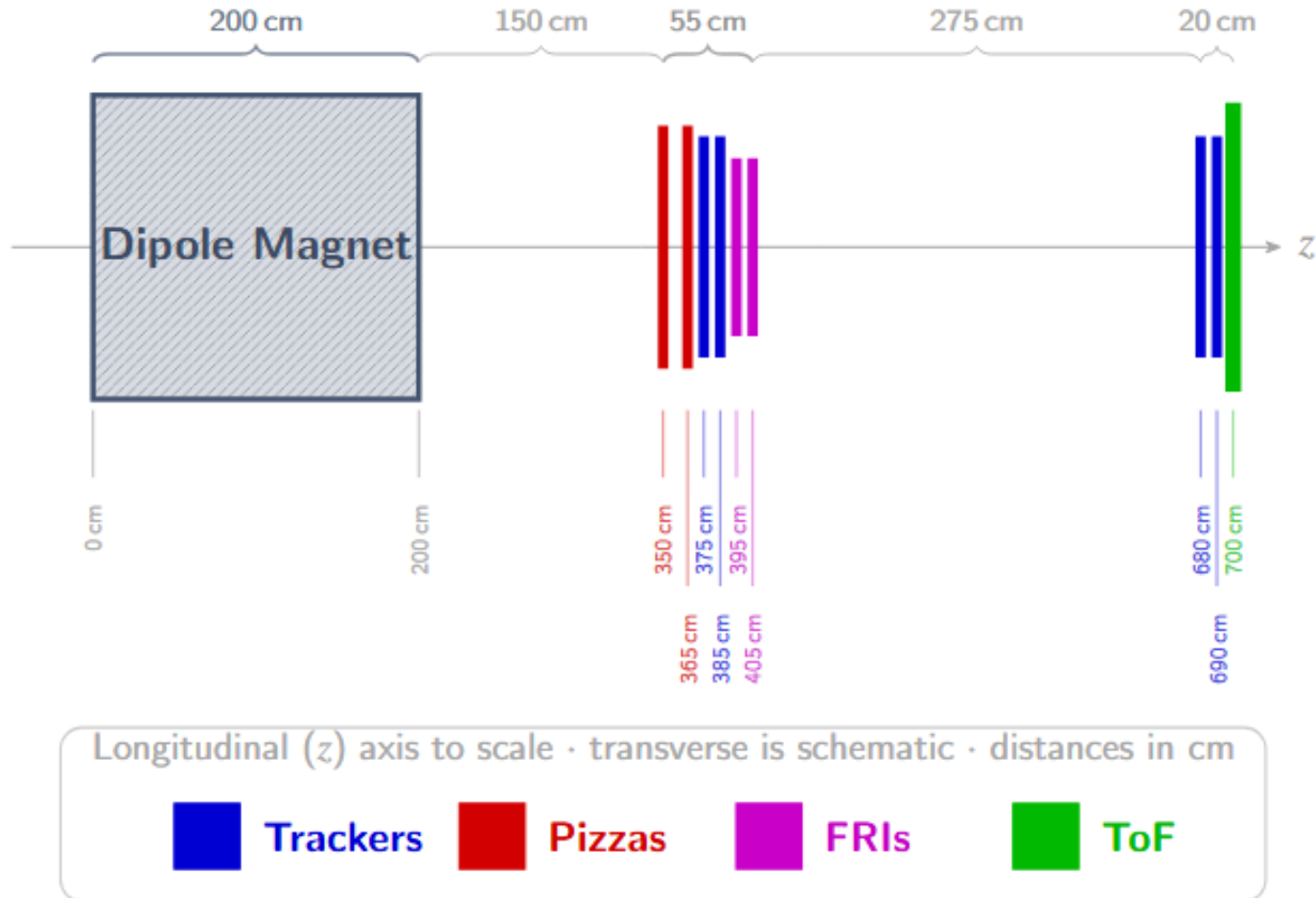



UNIVERSITY  
*of York*

# Absolute Normalisation

# $K_L$ monitoring

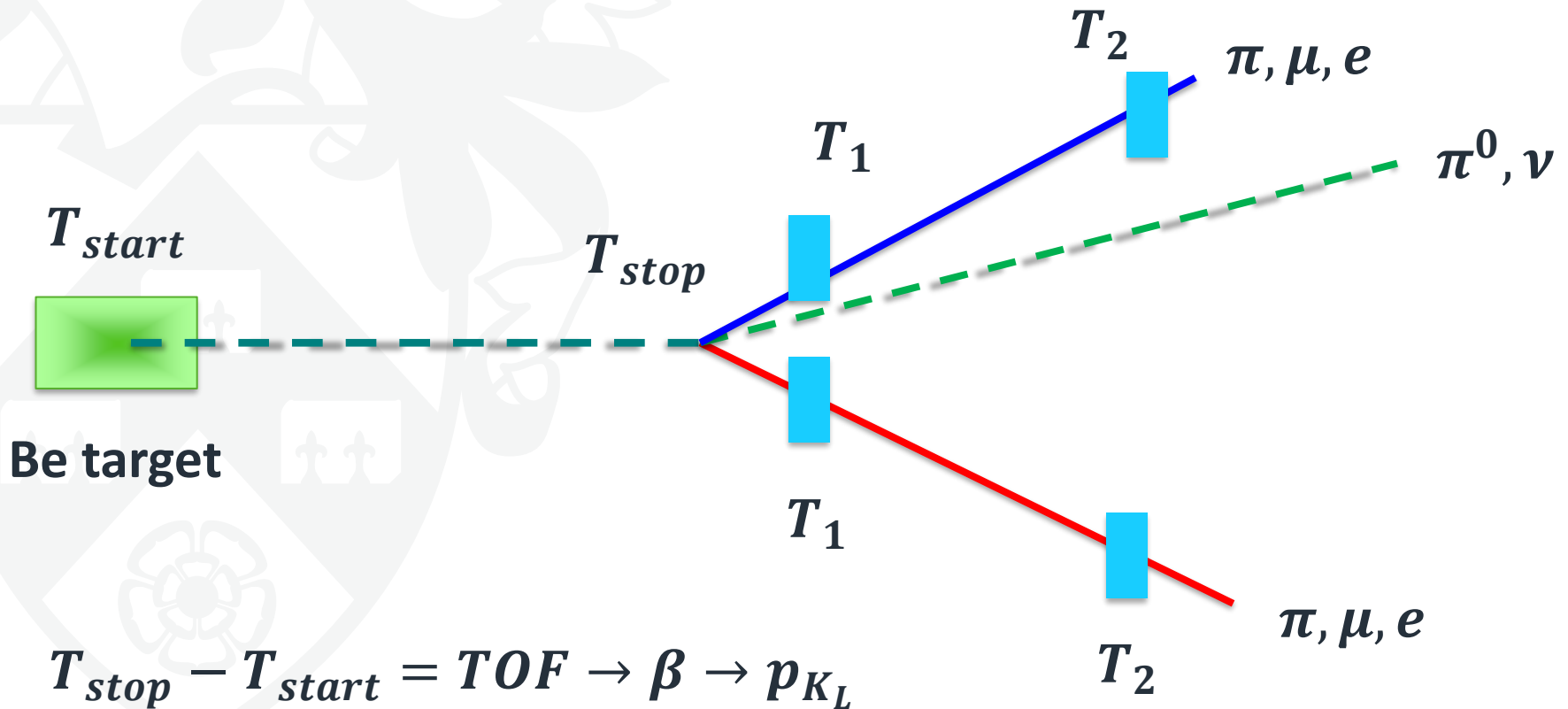



# $K_L - K_S$ regeneration

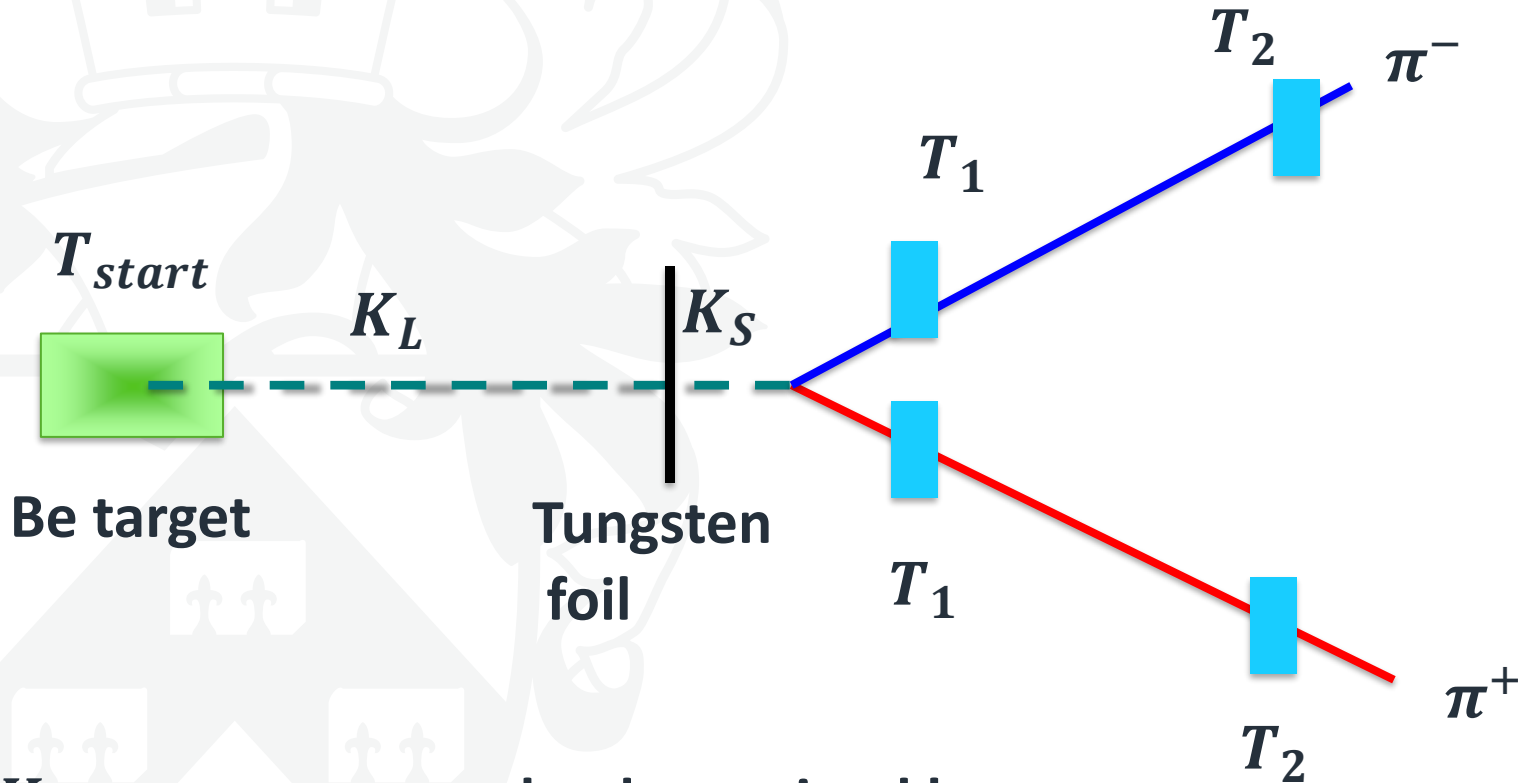

$K_L$  momentum can be determined by

- TOF
- $\pi^+ - \pi^-$  opening angle

# $K_L - K_S$ regeneration

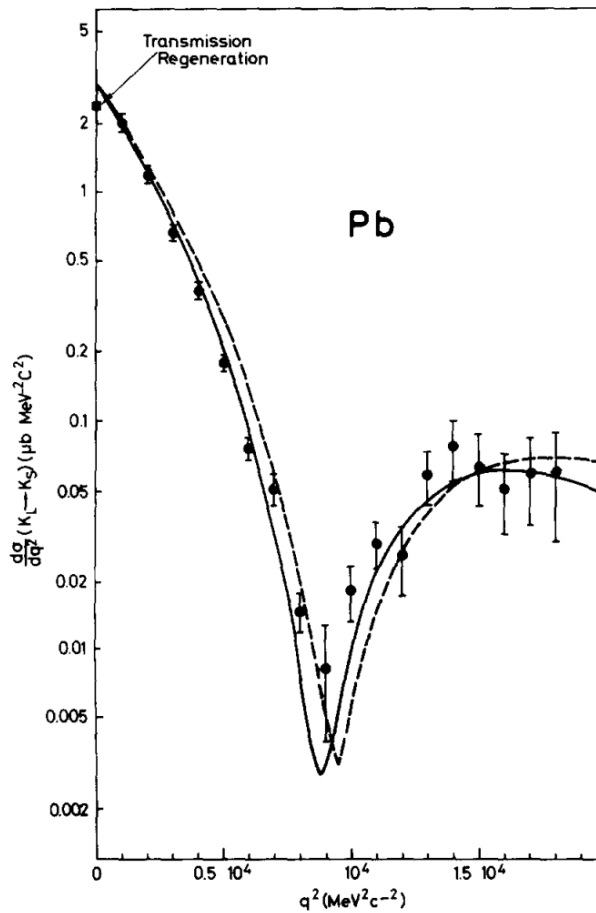

Cross-section is large

$$\sigma_{K_L} \cong \sigma_{K_S}$$

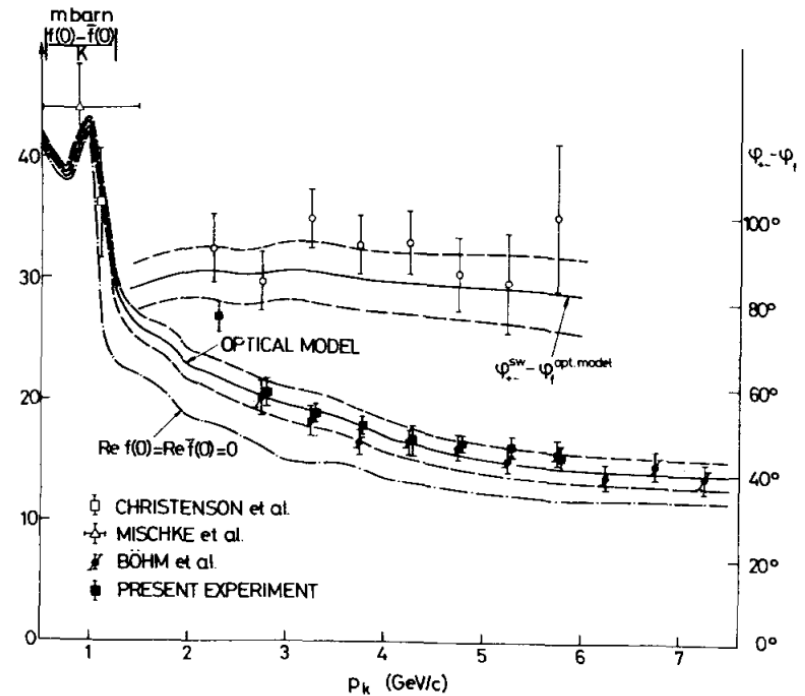
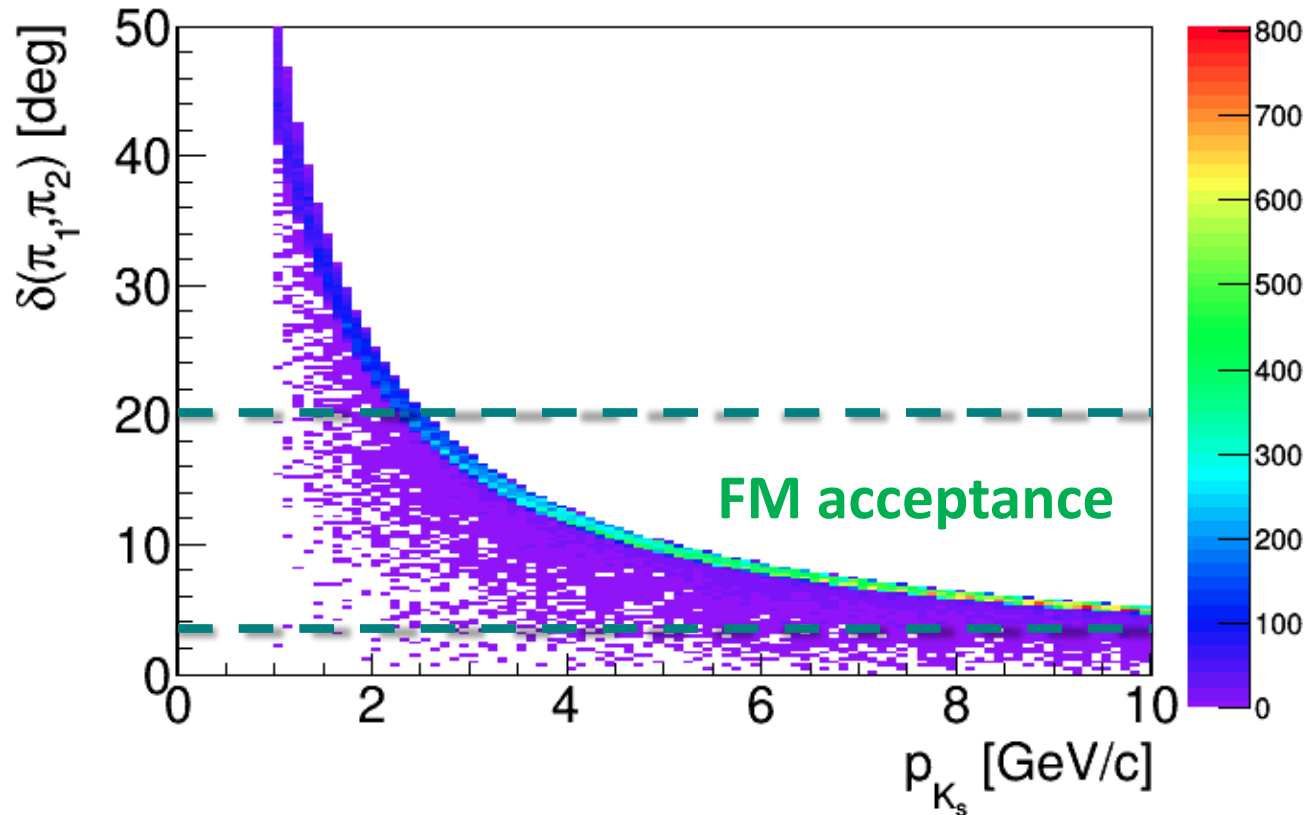

Fig. 3. Forward regeneration amplitude (left scale) and interference phase  $\phi_{+-} - \phi_{f(D)}$  (right scale) as functions of momentum. The curve labelled  $\phi_{+-}^{SW} - \phi_{f(D)}^{opt. model}$

# $K_L - K_S$ regeneration



- Absolute time calibration via  $\delta_{\pi\pi}$  vs TOF
- Alternative method to extract kaon flux – systematics
- Reliable way to monitor high-energy  $K_L$  flux

# $K_L - K_S$ regeneration

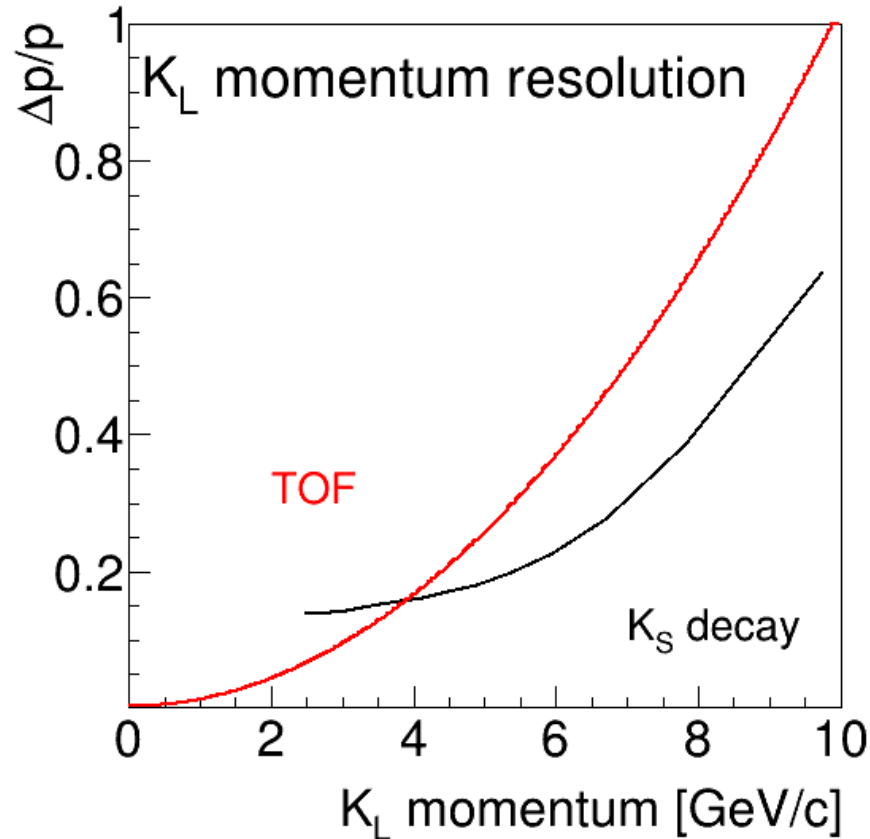

- $K_S \rightarrow \pi\pi$  about 1 event per second with  $\sim 1$ mm thick W foil
- Highest kaon flux around 4 GeV/c

# $K_L - K_S$ regeneration rates and backgrounds



Relative  $K_S/K_L$  rates in Flux monitor

Condition	$K_S$	$K_L$
Total	1	25
Coplanarity $< 5^\circ$	1	1
Vertex+ Coplanarity	1	0.03

- $K_S \rightarrow \pi\pi$  selection is clean

# Status

- Hardware
  - Ready to be transported
- Electronics and readout
  - Hall-D
- Layout
  - Conceptual design complete
  - Ready for engineering drawings
- Absolute calibration
  - $K_s$
- Software
  - Standalone
  - Implementation into Hall D GEANT after FM engineering design

# Wasa detectors

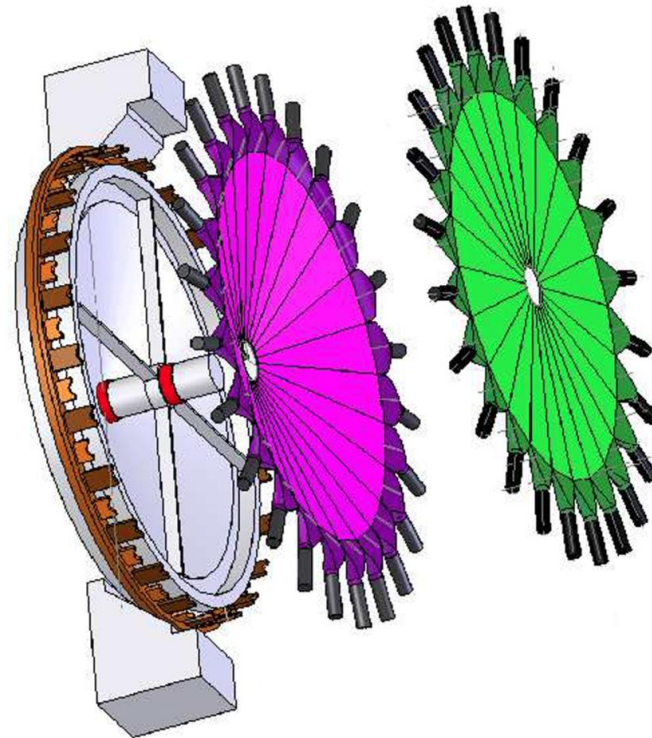
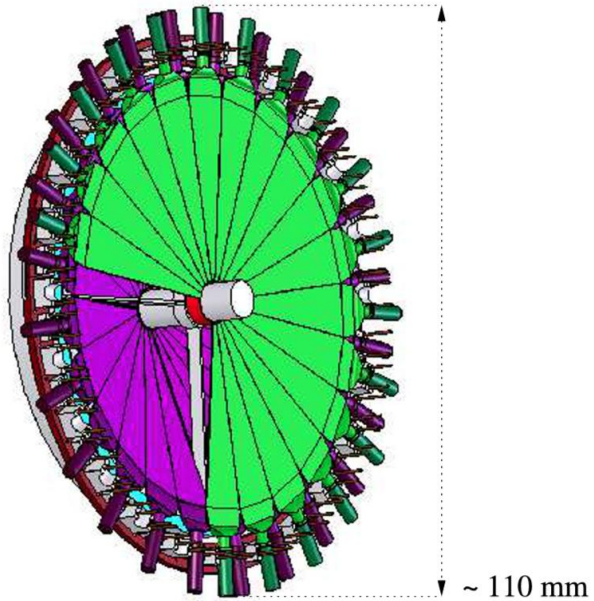

# Wasa detectors

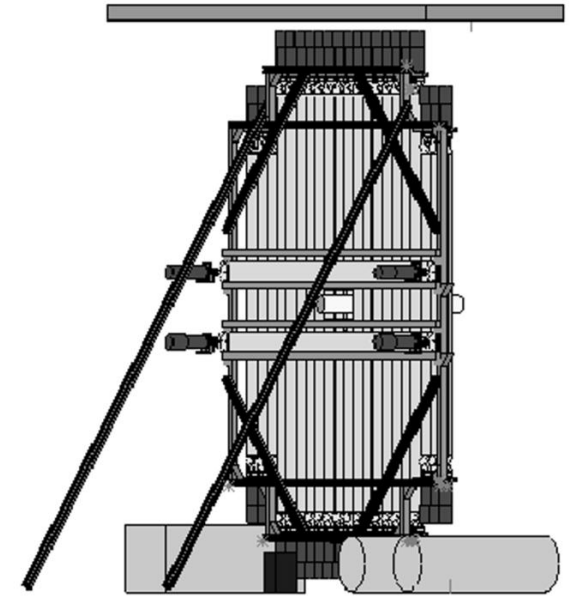
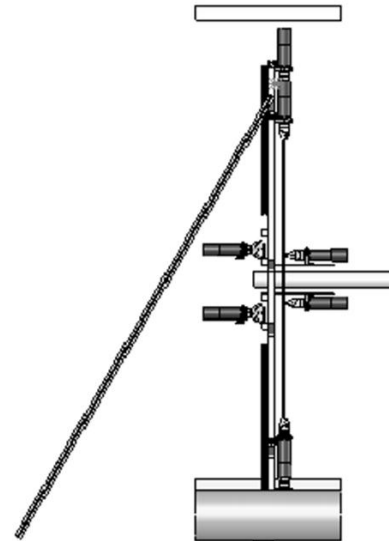
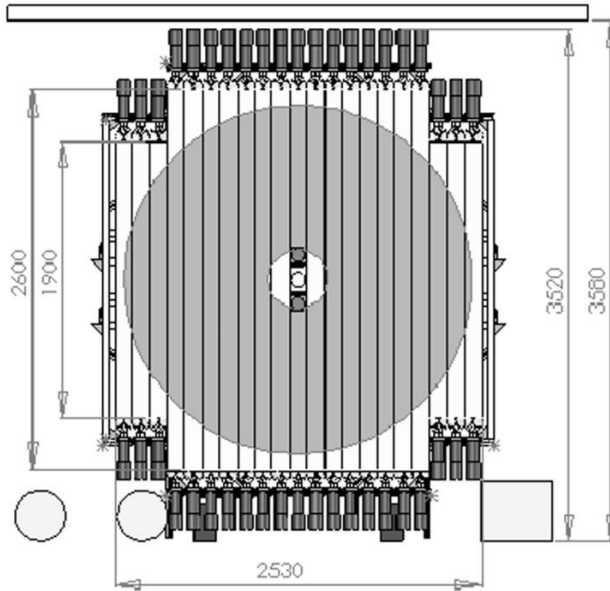

# Wasa detectors



# Wasa detectors

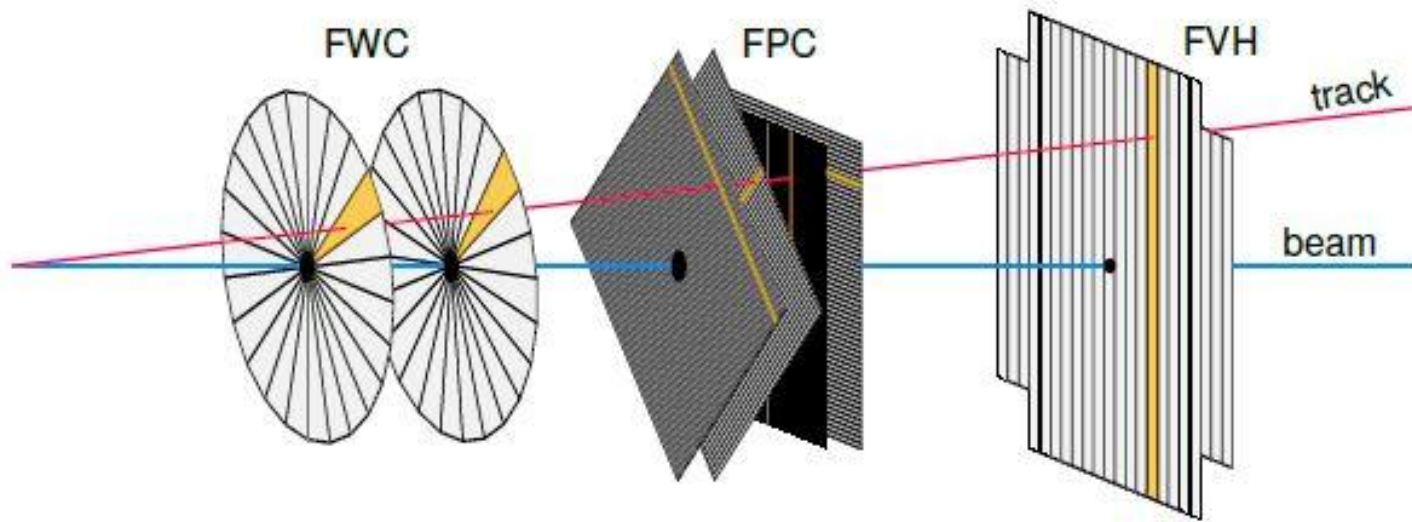

Used in TOF mode for the isospin violating  $dd \rightarrow {}^4\text{He}\pi^0$  experiment

# Wasa detectors

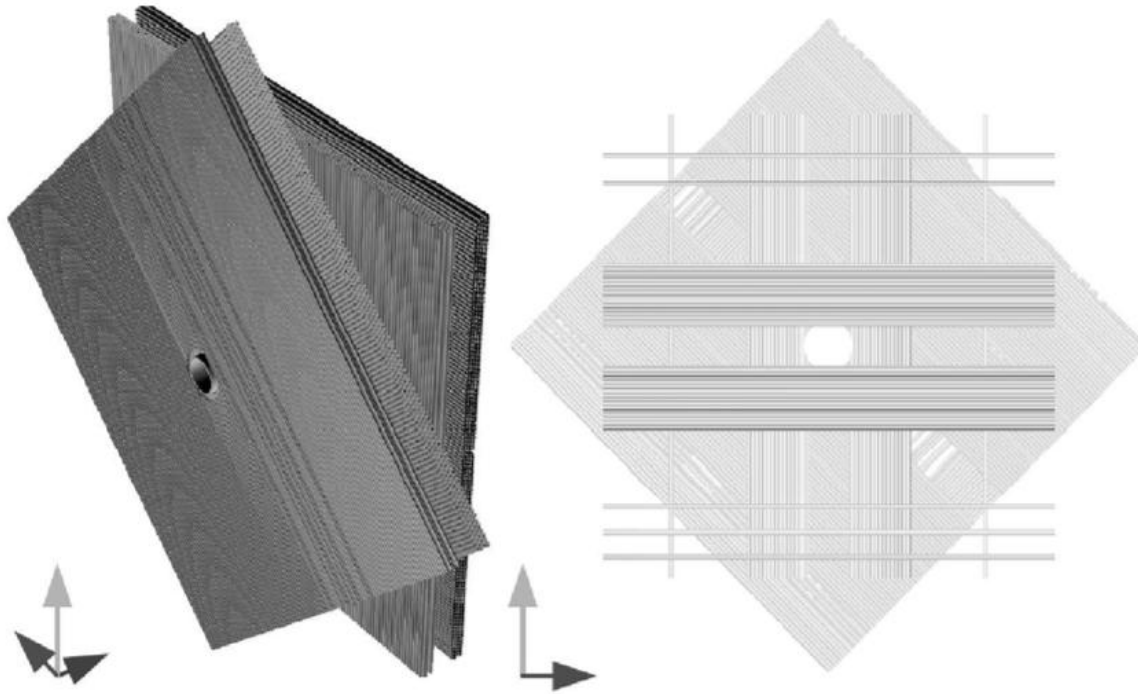

(b) *Forward Proportional Chamber FPC*

# $K_L$ flux monitor location

