

Development of a GEM-Based Transition Radiation Detector for GlueX-III

Lauren Kasper
Vanderbilt University

The GlueX Experiment in Hall D

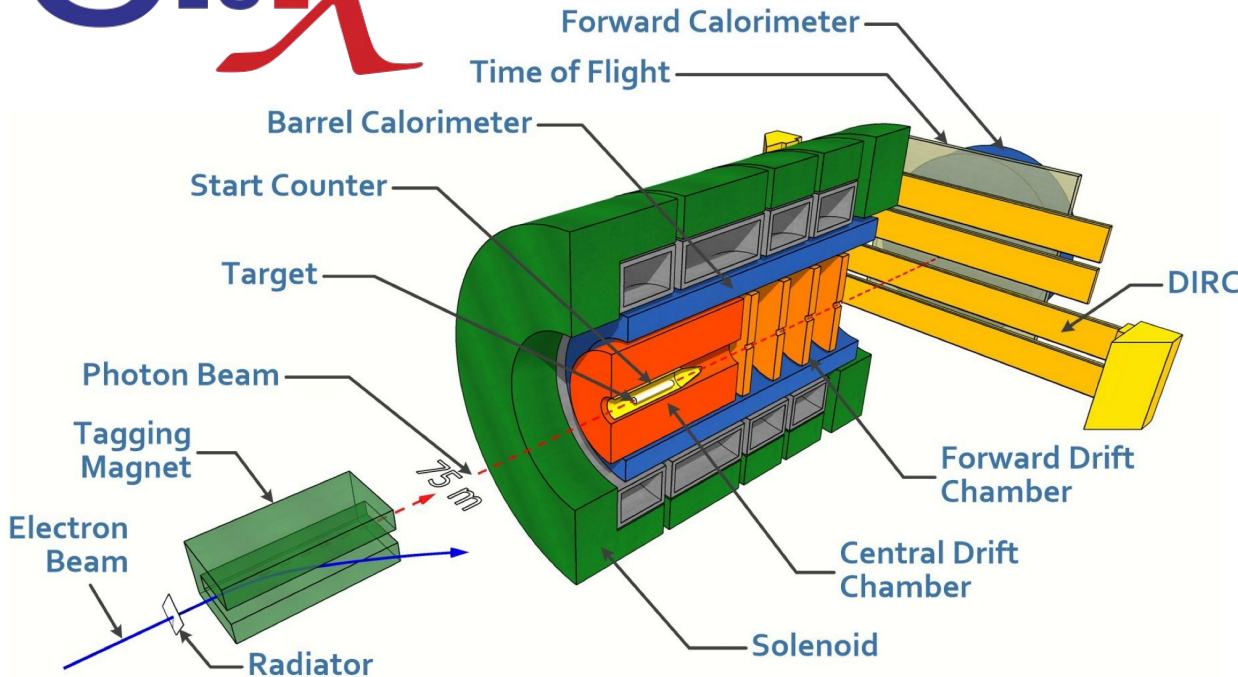

NIM A 987 (2021) 164807

- Photon beam from 12 GeV electron beam, incident on a proton target. Up to 9 GeV linearly polarized
- Major goal: search for exotic mesons
- $\sim 4\pi$ acceptance
- Currently running GlueX-II phase

GlueX Phase III Physics Program

- Results on J/ψ production at threshold are most cited to-date from GlueX data sets
- GlueX-III planned for 2027-2028, running with doubled intensity
- Focus is charmonium production near-threshold; ability to probe gluonic QCD in uniquely sensitive kinematic regime
 - Access to gluon content of the proton (GFFs, GPDs)
 - Search for LHCb pentaquark (s-channel)

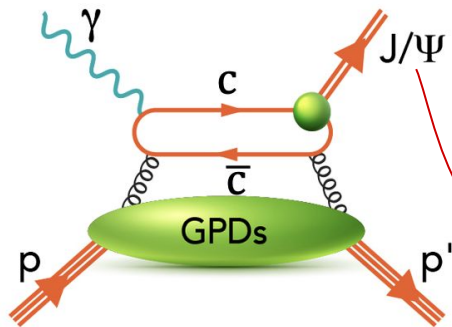

Exclusive J/ψ photoproduction at threshold, sensitive to gluon GFFs

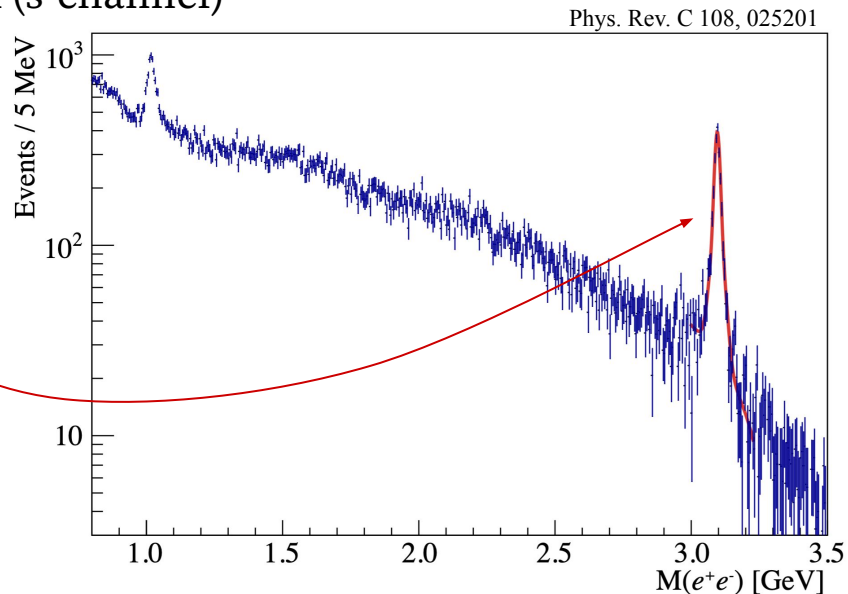

The Challenge

- GlueX-III = significant increase in J/ψ statistics, access to higher mass charmonium states ($\psi(2S)$, χ_C)
- More precise cross section measurements for $c\bar{c}$ states will motivate & constrain theoretical understanding of $c\bar{c}$ photoproduction
- Significant pion background limits measurement purity/precision, limits understanding of reaction mechanism

Primary observables:

$$\gamma p \rightarrow J/\psi p \rightarrow e^+ e^- p$$

$$\gamma p \rightarrow \psi(2S) p \rightarrow e^+ e^- p$$

$$\gamma p \rightarrow \chi_C p \rightarrow \gamma e^+ e^- p$$

Dielectrons provide clean final state, but are rare

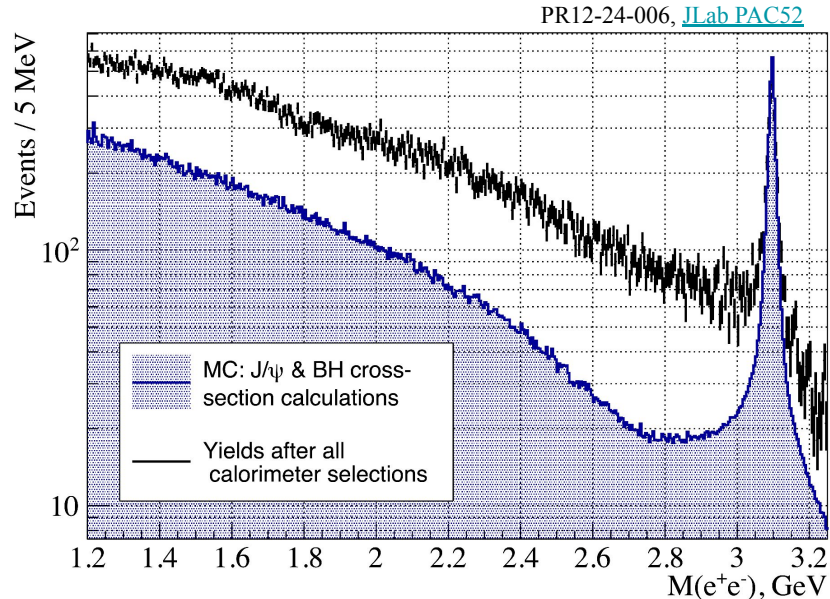

Transition Radiation: e ID + Charged Tracking

- Relativistic e 's emit TR when crossing boundary between media of different refractive indices (TR emission $E \propto$ particle's γ -factor)
- Detect dE/dx from charged particles, plus TR X-ray clusters (~ 2 -40 keV) using high-Z gas (Xe)
- Goal: high pion suppression factor, ideal e/π discrimination from $2 \lesssim p \lesssim 100$ GeV/c
- Wire-based TRDs have been used previously (ALICE, HERMES, etc.)

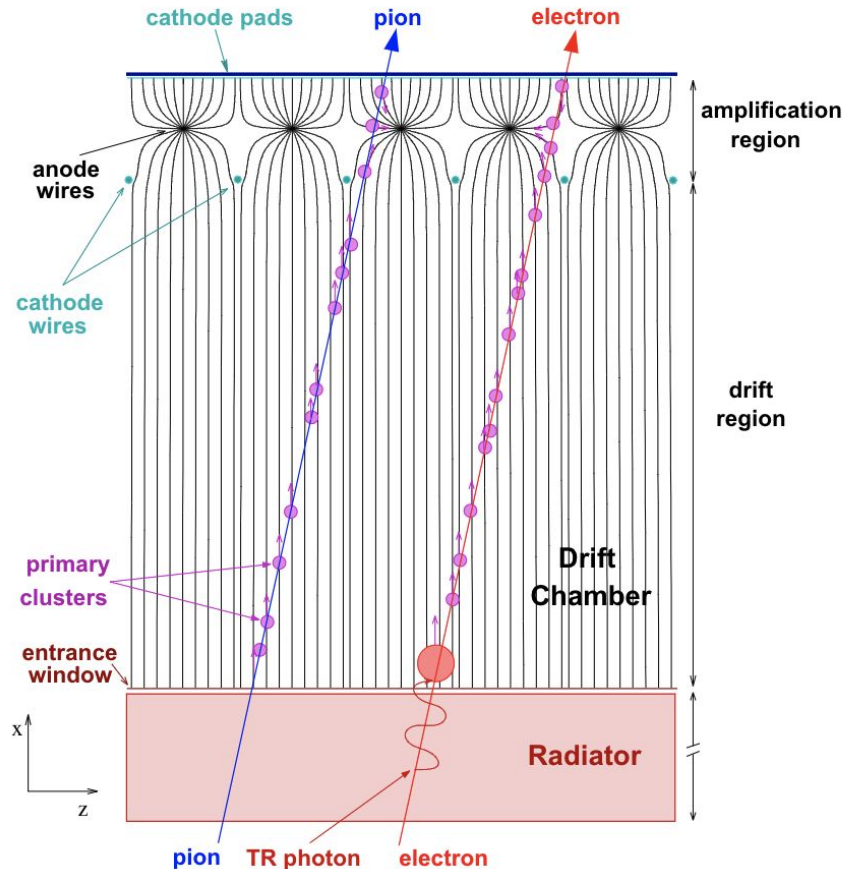

CERN-EP-2017-222, 2017

A Modern TRD Concept: GEM-TRD

- Performance issues in traditional TRDs (i.e. space charge effects) limit application in HENP. Motivates replacement with MicroPattern Gaseous Detector (MPGD) technologies, like GEMs (Gas Electron Multipliers)
- MPGD Advantages: High rate capability ($>10^6$ Hz/mm²), fast signal response, intrinsic spatial resolution (30-40 μ m), stable operation at high gain

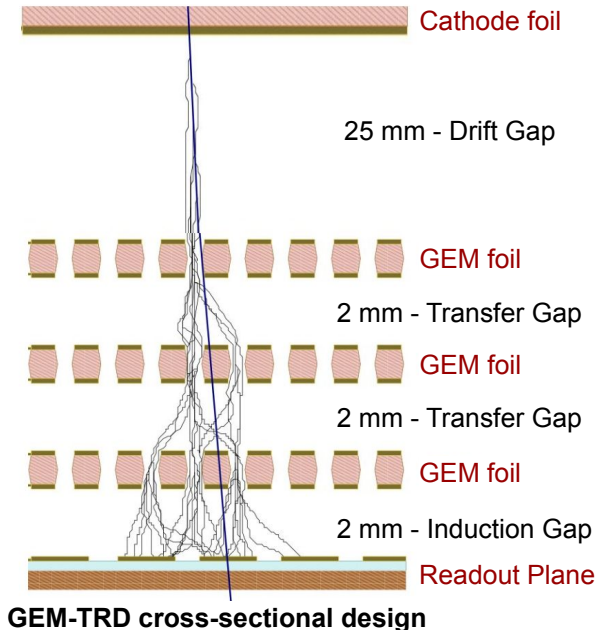

GEMs for TRD application require:

- Radiator material (many layers)
- Transparent cathode/gas window
- Heavy (high Z) gas
- Larger drift region
- Charge sampled in time (to discriminate dE/dx from TR X-ray deposits)

GlueX-III GEM-TRD Design

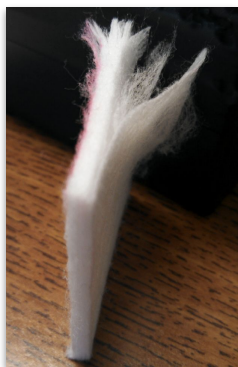
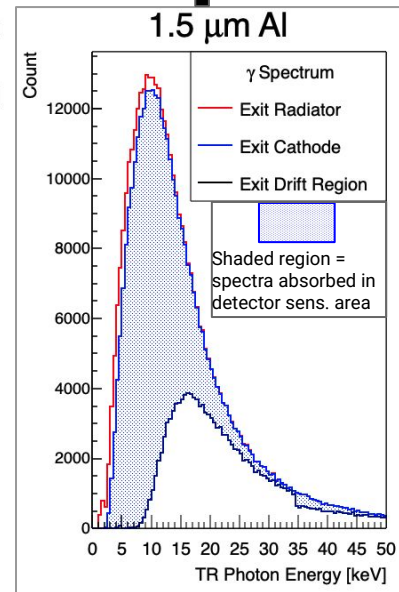
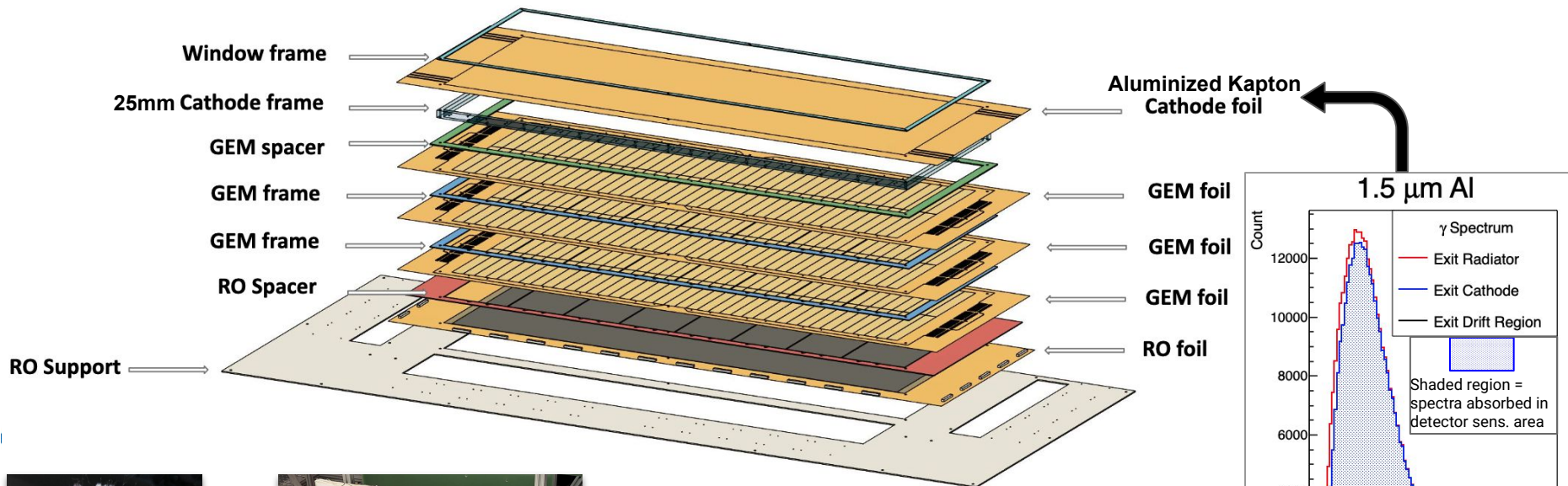

Total Active Area: 100.8cm x 144cm
Drift Region: 2.5cm

TR Radiator: 20cm fleece ($0.08\text{g}/\text{cm}^3$)
Total Radiation Length: $\sim 4\%$

- GEMs typically use APV25 FEE (charge-integrating). For TRDs, need charge sampled in time to discriminate dE/dx from TR X-rays
- A FE chain optimized for fast sampling requires higher effective GEM gain ($>10^4$) for adequate signal-to-noise ratio
- OpenVPX electronics will be used in place of JLab-developed FlashADCs
 - More powerful FPGAs = potential for streaming readout, real-time tracking, etc.
 - 160 channels per module (high density)
 - 6.6ns sampling time
 - 12 bit ADC

Jülich-designed modules for PANDA tracker*, modified by us for GlueX TRD project

Status: under development, with some boards in hand



Analog processing



Digital processing

* L. Jokhovets et al 2022 JINST 17 C04022

Planned GlueX-III GEM-TRD Upgrade

- 20cm fleece radiator, 2.5cm drift region, $\sim 100 \times 144 \text{ cm}^2$ active area, 4896 RO channels, 2D strip readout (capacitive coupling & 1mm pitch)
- Xe:Isobutane (90:10) gas with purification/recirculation system, Jülich-developed OpenVPX electronics

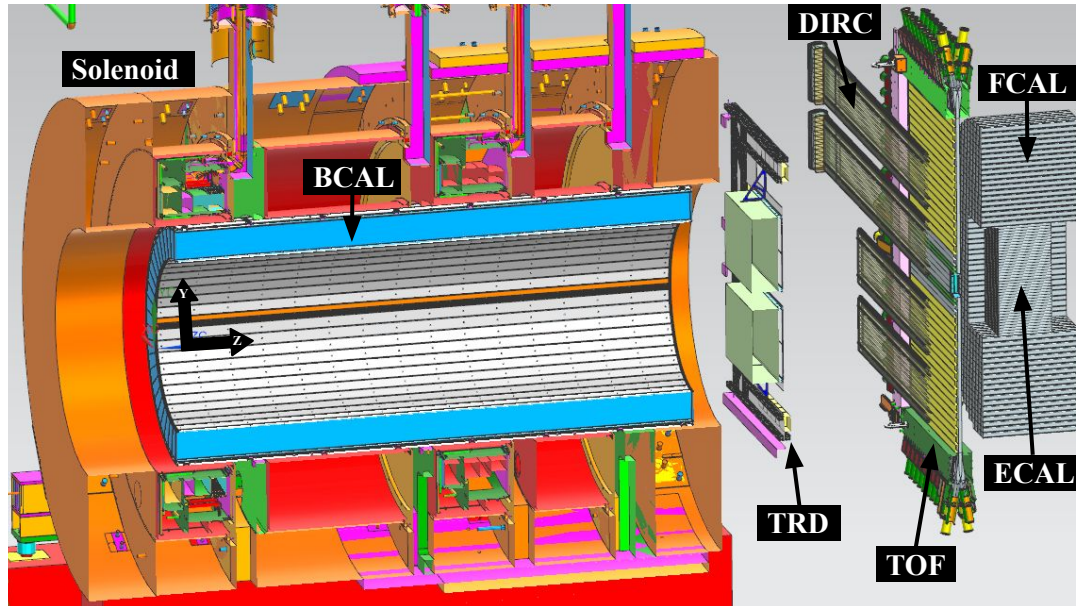

*Drift chambers not shown in cutaway

Upstream View in GlueX-III

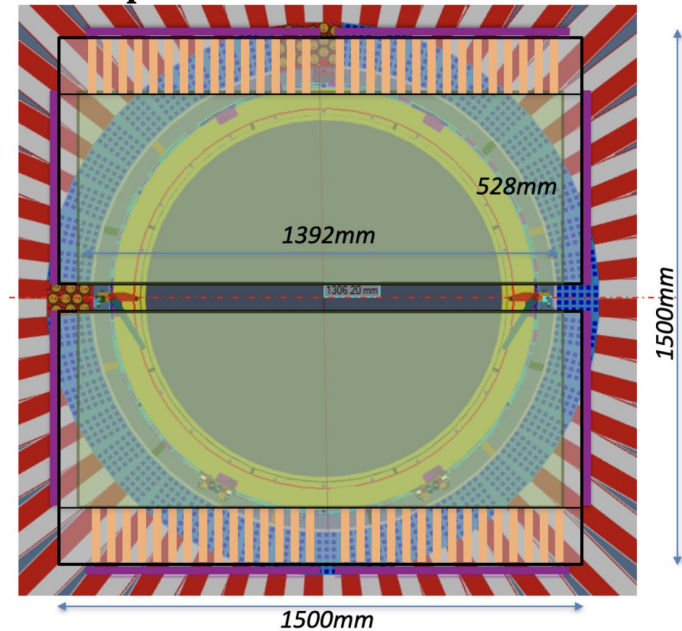

Quarter-Size GEM-TRD Prototype

- 20cm fleece radiator, 2.5cm drift region, $\sim 52 \times 72$ cm² active area, Kr:CO₂ (90:10) gas, 1080 RO channels with FlashADC electronics (8ns sampling)
- Tested in experimental acceptance during GlueX-II 2025 commissioning period for ~ 3 weeks. Integrated with the GlueX DAQ and reconstruction software

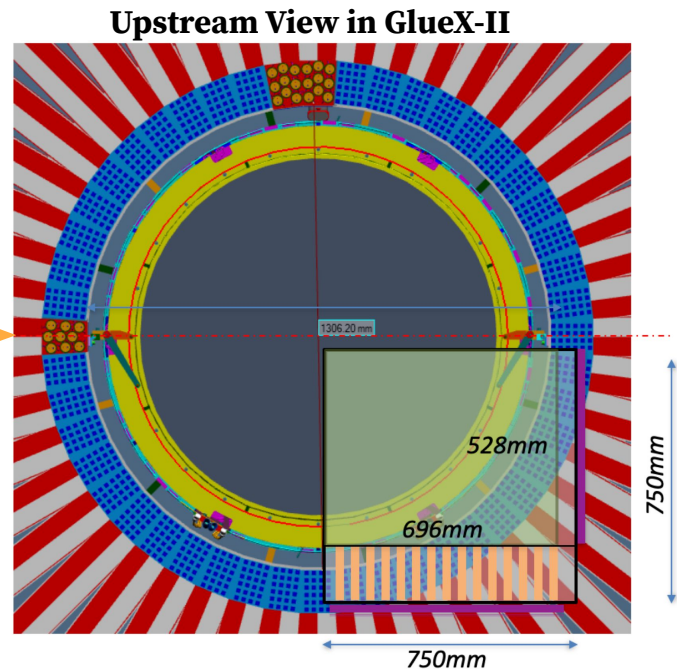
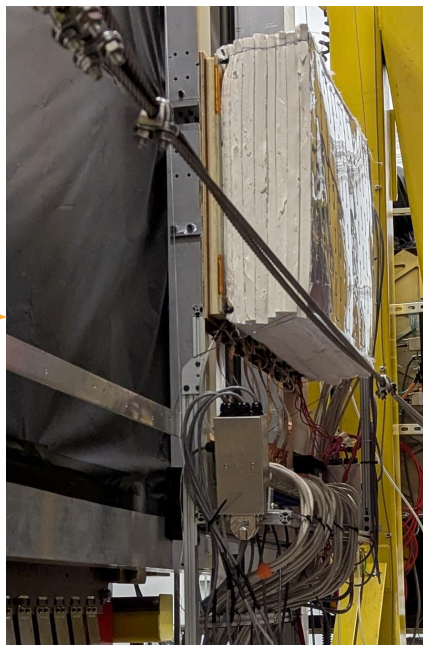
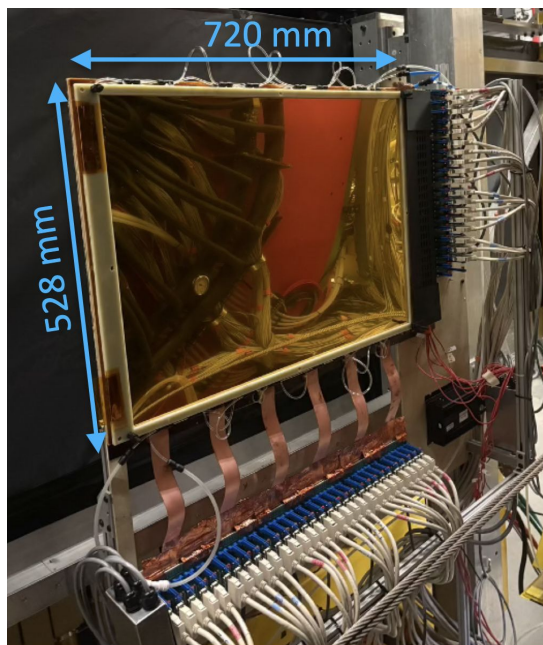

GEM-TRD Prototype Technical Performance

Main goal: testing performance in real GlueX environment (stability, noise, gain, electronics, DAQ rates/data volumes, etc.)

- Collected data for developing integration into GlueX software, like track-matching validation
- Collected $e^{+/-}$, $\pi^{+/-}$ samples to evaluate detector performance w.r.t pion suppression

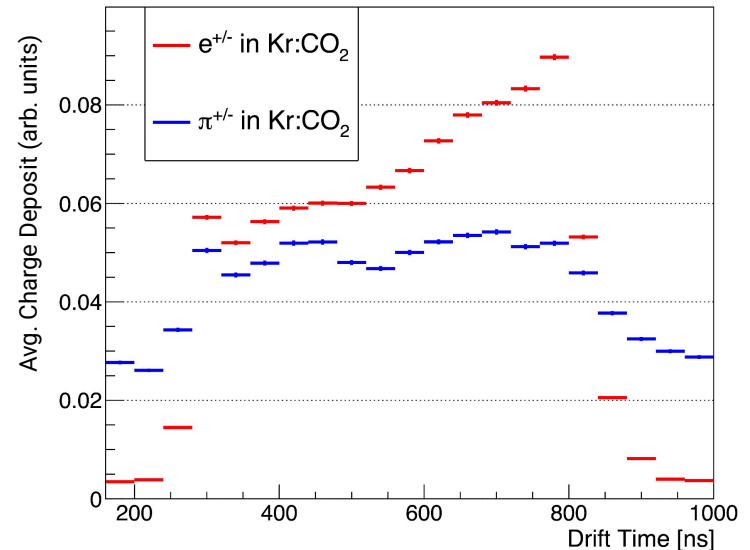
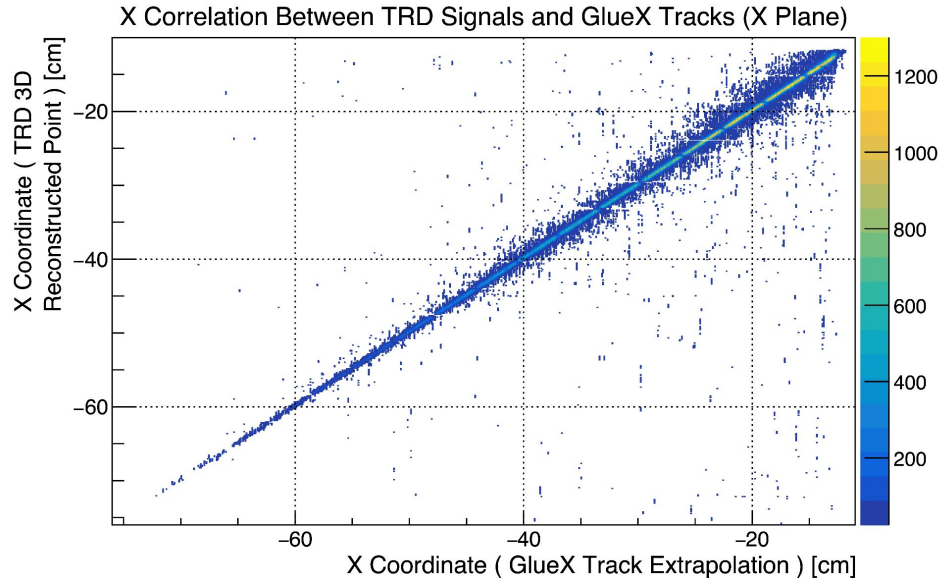

Maximum Amplitude Deposit in Drift Time

- Study detector response to $e^{+/-}$, $\pi^{+/-}$ samples from calorimeters

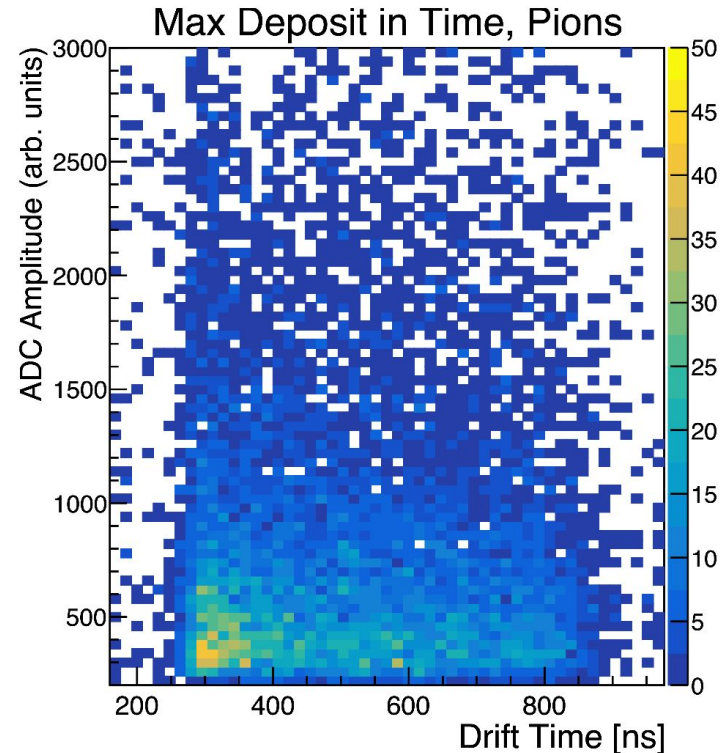
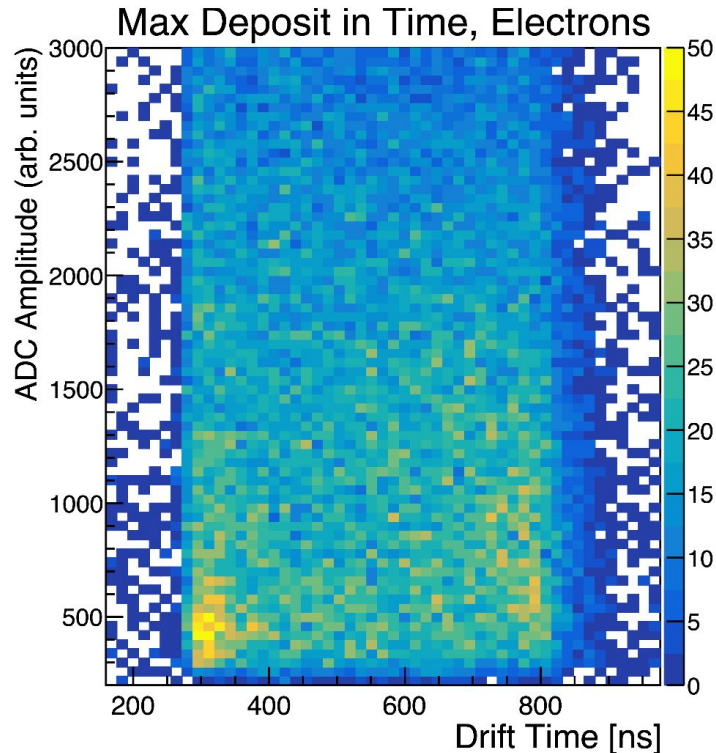

Maximum Amplitude Deposit in Drift Time

- Make simple cut on 2D TRD response to minimize $\pi^{+/-}$ signals

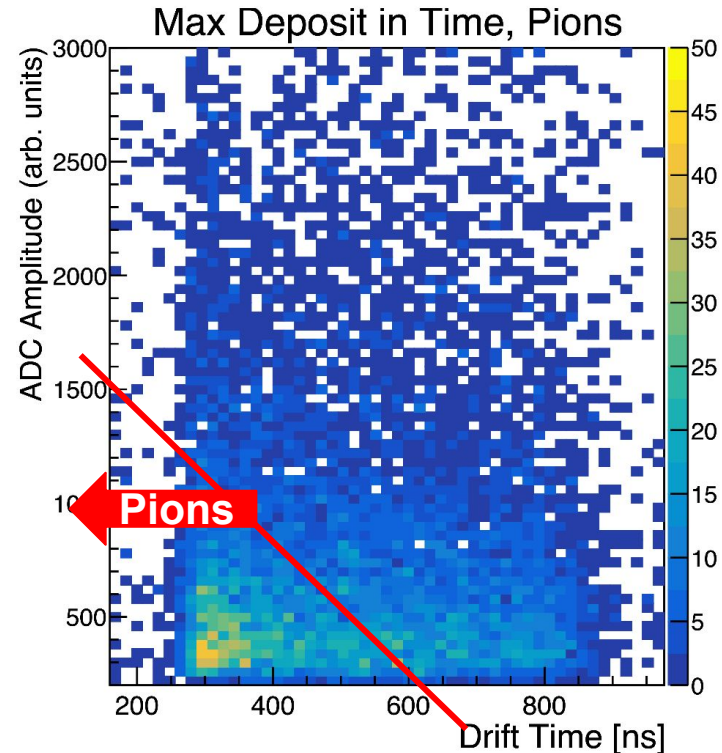
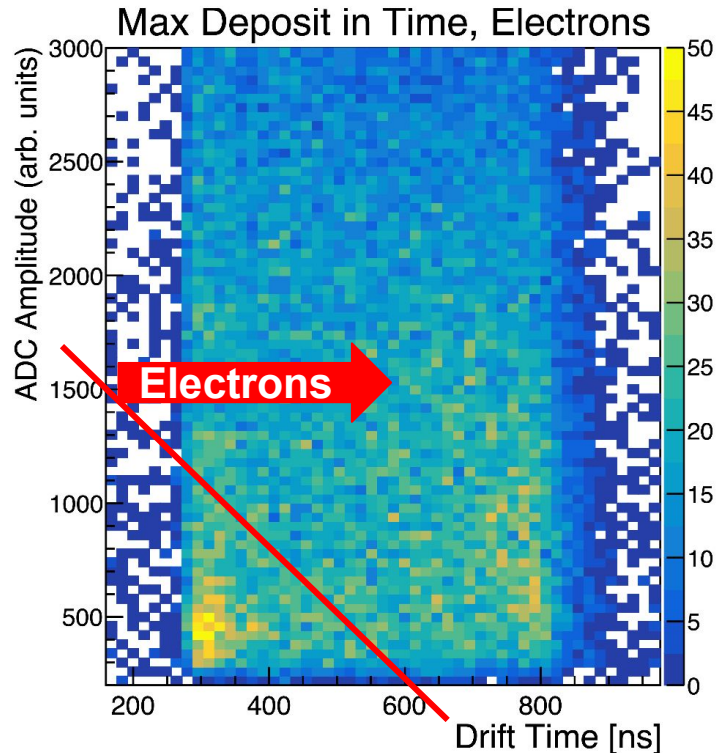

J/ ψ Reconstruction Using Events Extrapolated to the GEM-TRD Prototype

One J/ ψ event with TRD prototype in GlueX acceptance

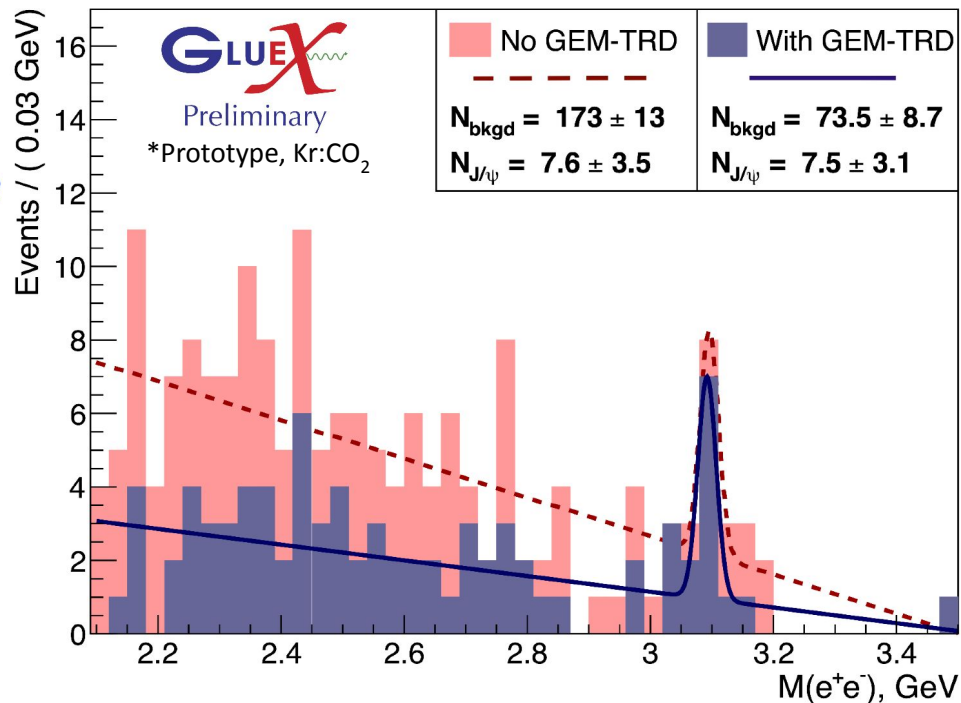
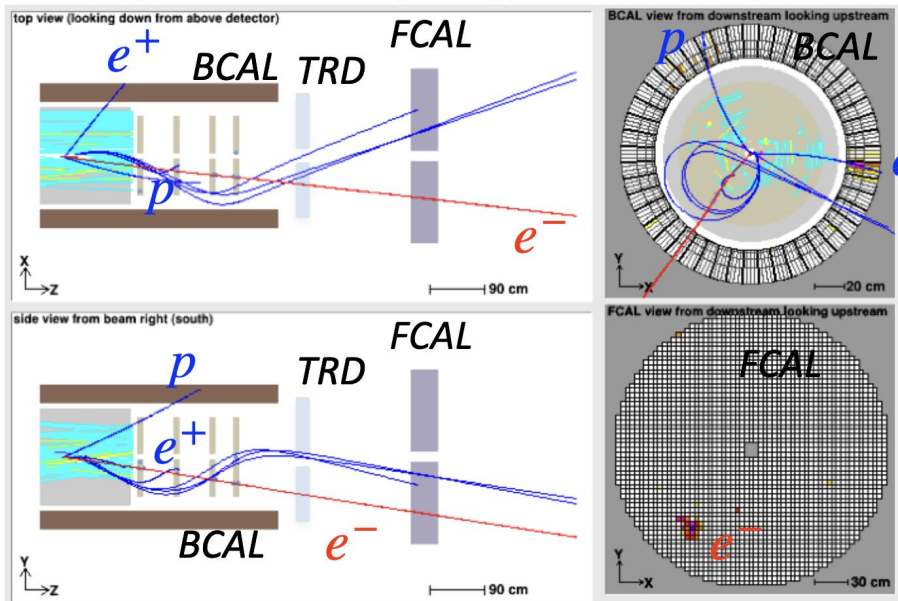

Suppression Performance Studies

NIM A 942 (2019) 162356

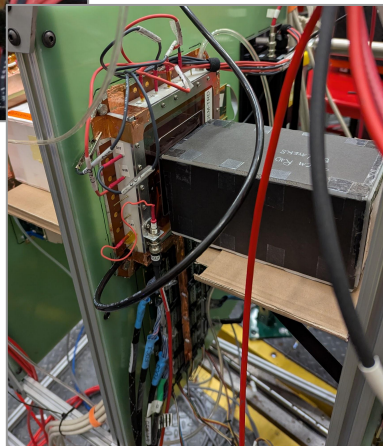
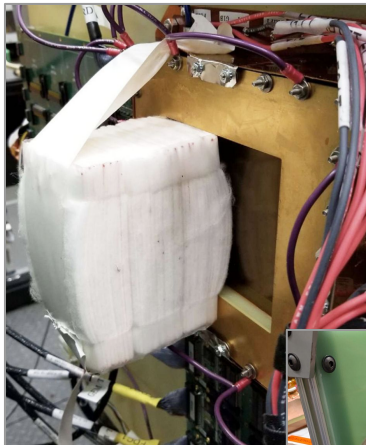

From 2025 Tests

NIM A 1087 (2026) 171403

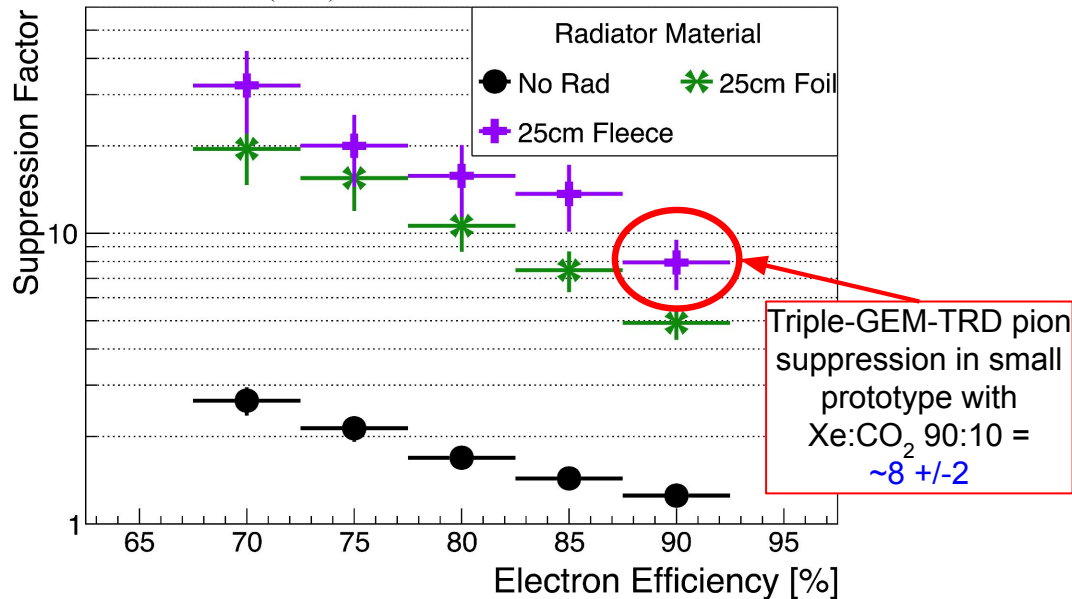

Projected Impact on GlueX-III Physics Program

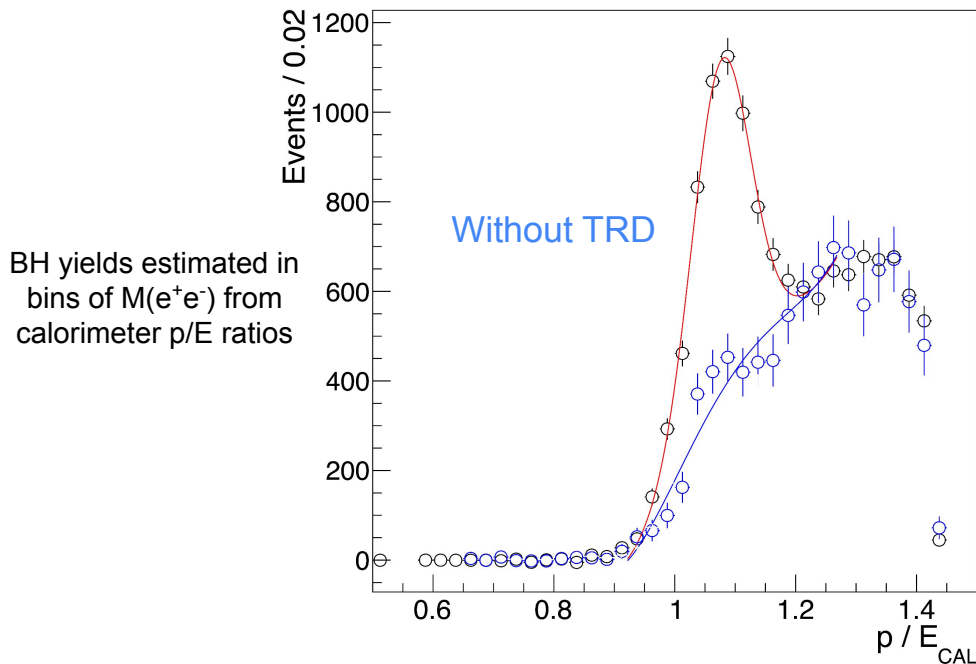

Example of projected performance using GlueX-I data for $1.73 < M(e^+e^-) < 2$ GeV

Projected Impact on GlueX-III Physics Program

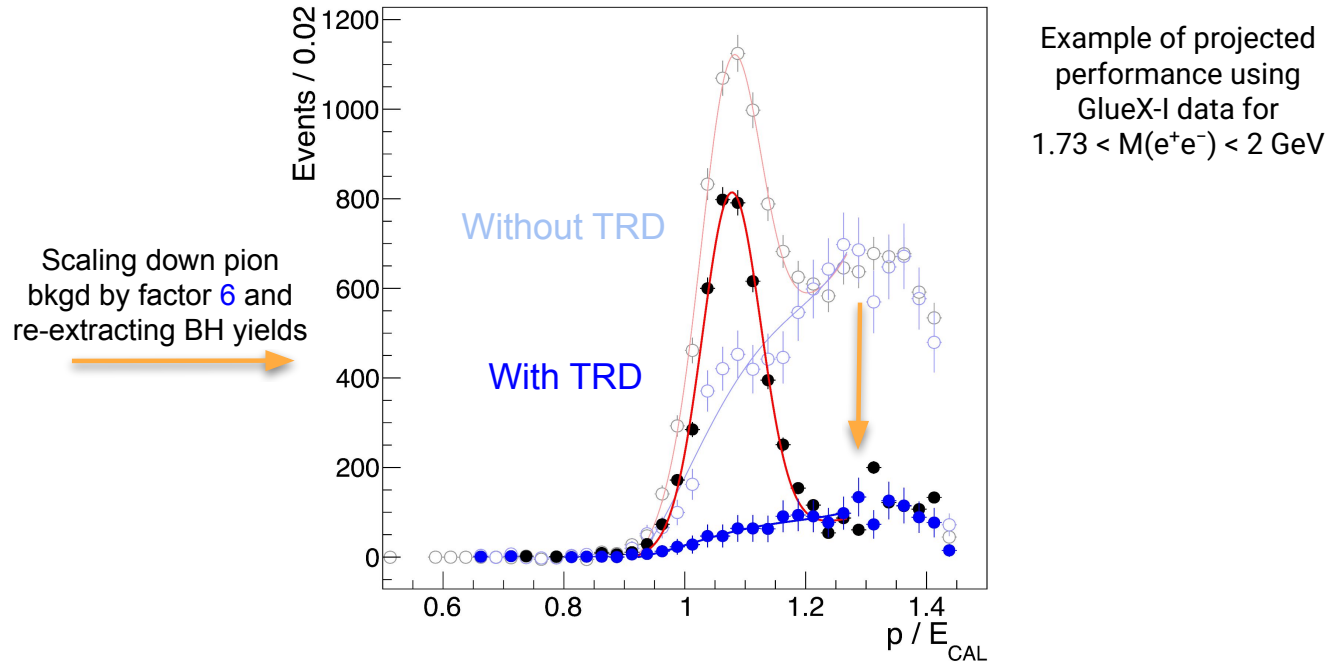

- Suppression of pion background in Bethe-Heitler process used to normalize J/ψ cross section \rightarrow reduce normalization uncertainties
- Suppress background under J/ψ peak, allowing higher-level angular/amplitude analyses

Summary

- A triple-GEM TRD enables e/π discrimination in high-background environments. Precise e ID ensures cleaner signals, essential for reducing combinatorial background in charmonium studies at GlueX-III
- Testing large-scale prototype in real experimental environment allowed critical insights, contributing to design & commissioning of final detector for GlueX-III
- This novel detector effort stands to have broader impact on technology choices for future experiments and facilities, like EIC

This work was supported in part by
DOE Grant No. DE-FG05-92ER40712

Special Thanks to UVA, FSU, and to
GlueX for collaborating on this project



Backup

PID: e Identification

E-Calorimeters: Designed to measure total E of e 's & γ 's by total absorption (E/p)

Time-of-Flight (TOF)

$p \lesssim 2 \text{ GeV}/c$

Energy loss by ionization (dE/dx)

$p \lesssim 10 \text{ GeV}/c$

Cherenkov Radiation

$0.25 \text{ GeV}/c \lesssim p \lesssim 20 \text{ GeV}/c$

Transition Radiation (TR)

$1 \text{ GeV}/c \lesssim p \lesssim 150 \text{ GeV}/c$

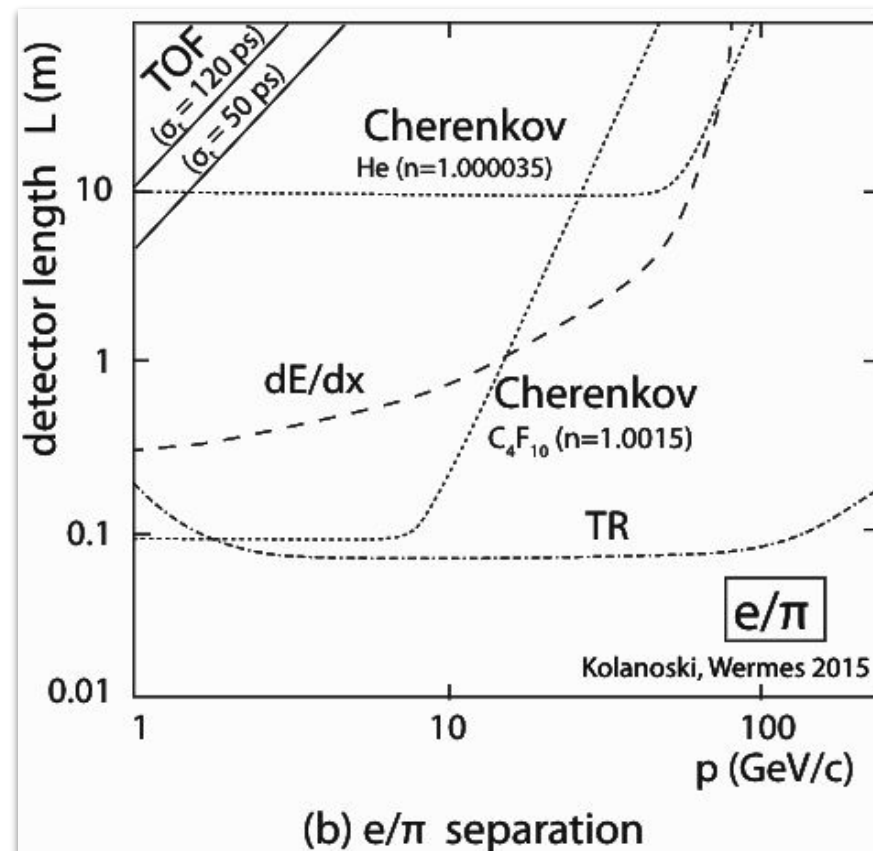

Kolanoski, H., and Wermes, N. "Particle Detectors Fundamentals and Applications." 2020

TRD Princ. of Operation

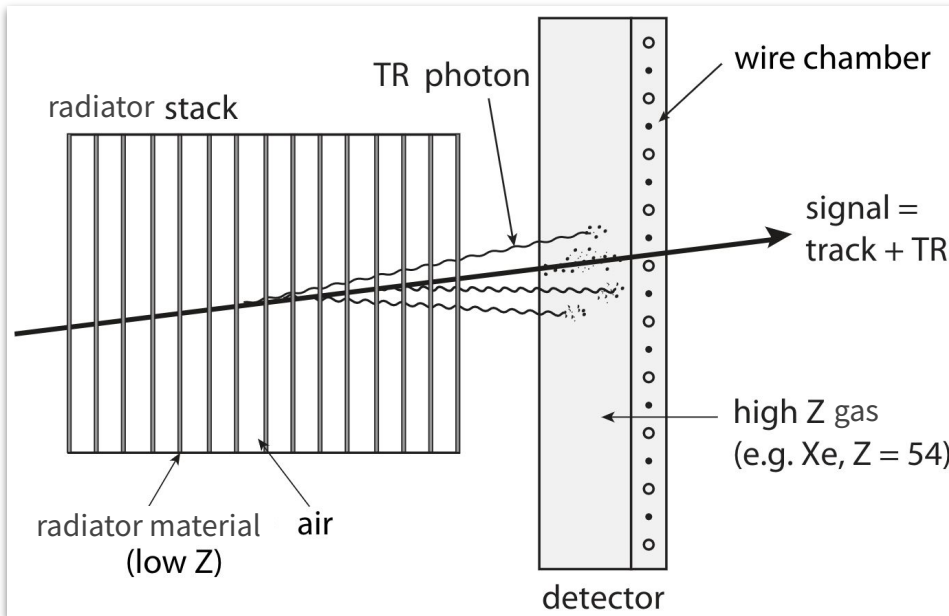

ISBN 13: 9780198858362

TR X-rays produced when relativistic particles ($\gamma \gtrsim 10^3$) cross boundary between media of different refractive indices

Total TR energy emitted $\propto \gamma$ -factor of particle

TR yield: $\sim 1\%$ per crossing \rightarrow need multiple interfaces (e.g. radiator stack) to boost

X-rays ($\sim 2-40$ keV) exit radiator, detected by highly absorbing (high Z) gas-filled wire chamber. The charged particle also traverses the chamber, leaving an ionization signal

Measuring total E deposited in the detector \rightarrow effective for separating particles which produce TR (e) from those that don't (π)

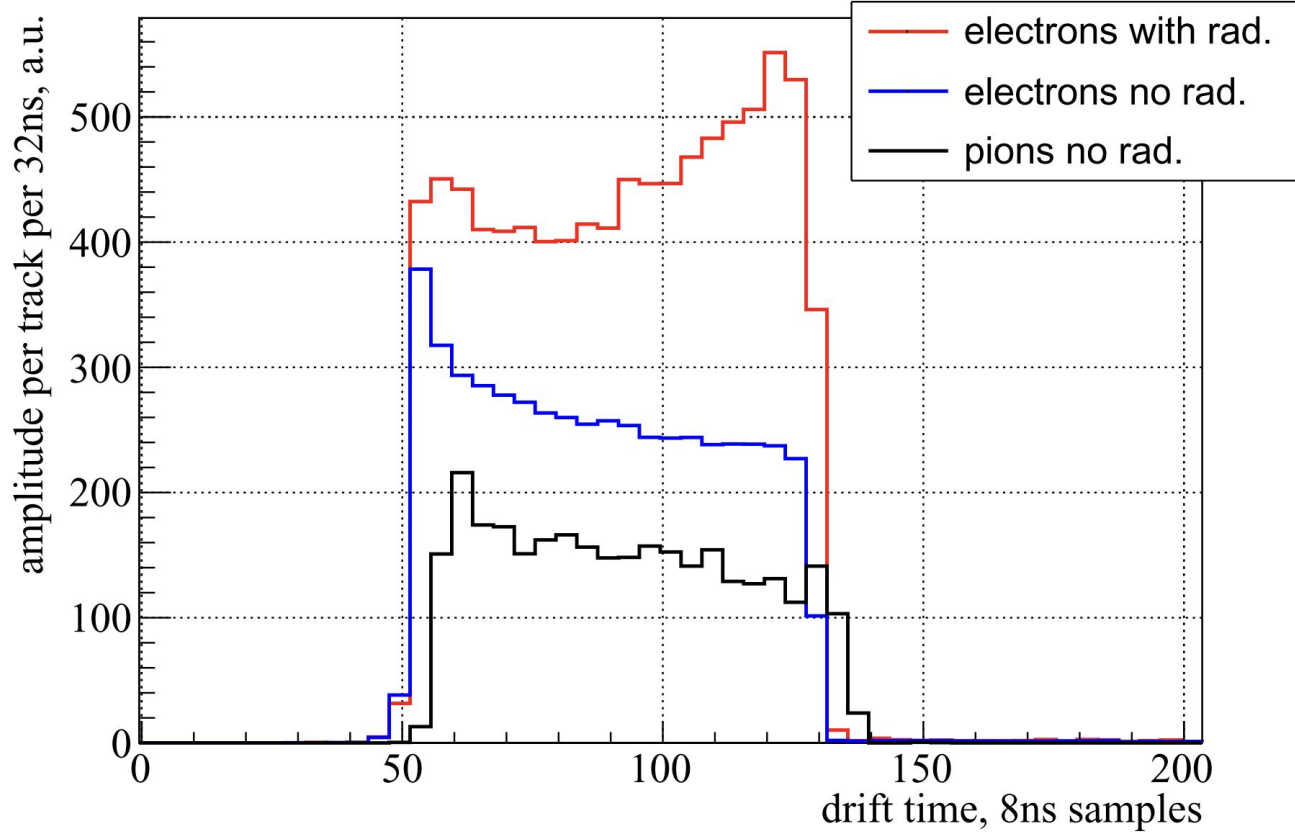

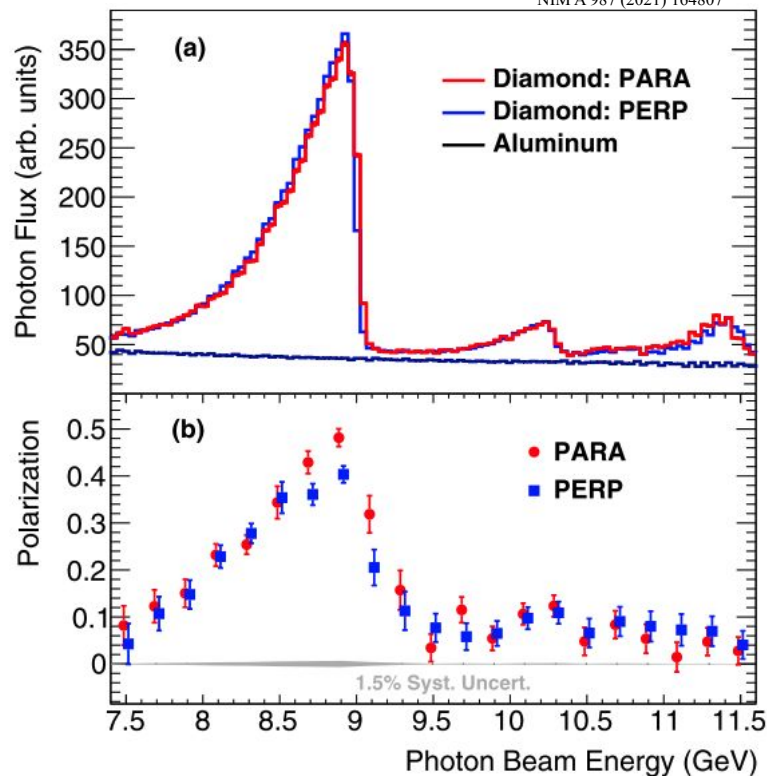

(Top) Measured collimated photon beam intensity vs energy. (Bottom) Measured collimated photon beam polarization vs energy

- Photon energy tagged by scattered electron: 0.2% resolution
- Intensity: $\sim 2 \times 10^7 - 5 \times 10^7$ γ/sec above J/ψ threshold (8.2 GeV)

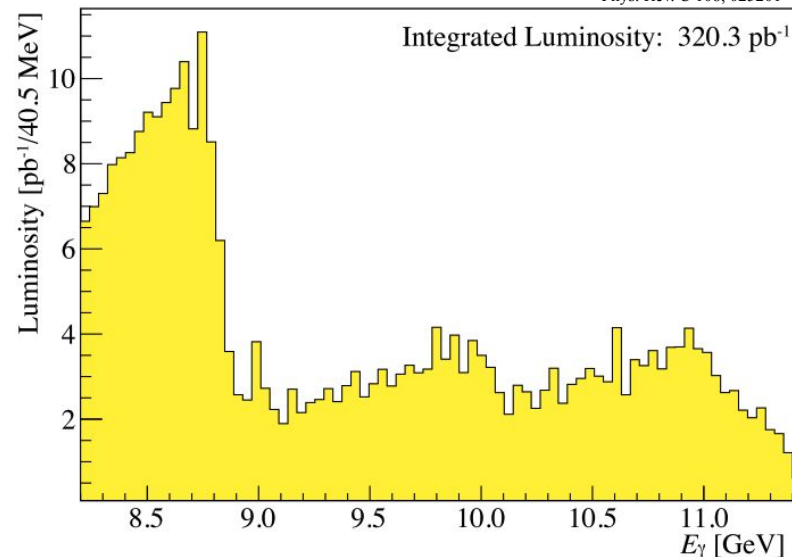

Measured tagged photon spectrum for GlueX Phase-1

GEM-TRD Concept - Why GEMs?

- Space charge effects in traditional wire-based amplification structures have resulted in performance issues for TRDs, limiting their application in HENP experiments
- Motivates replacement of amplification stage with MicroPattern Gaseous Detector (MPGD) technologies such as Gas Electron Multipliers (GEMs)

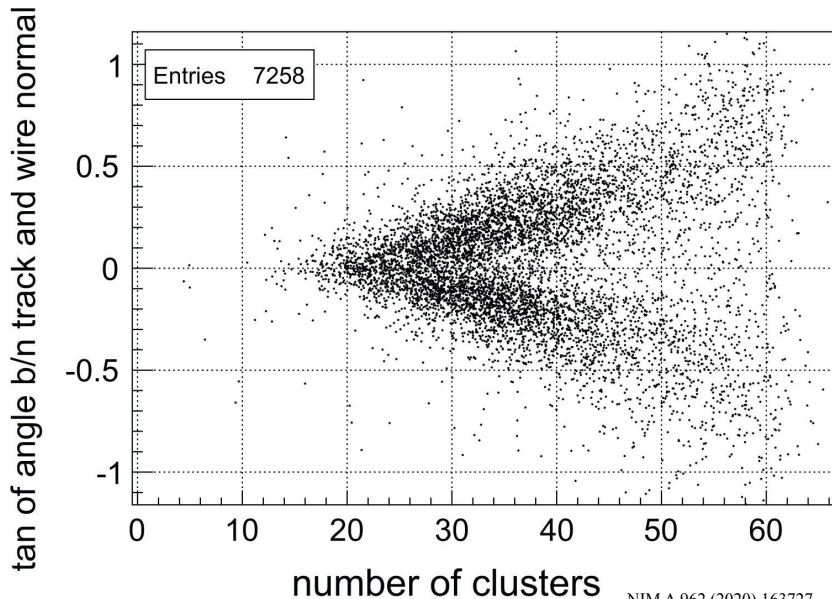

NIM A 962 (2020) 163727

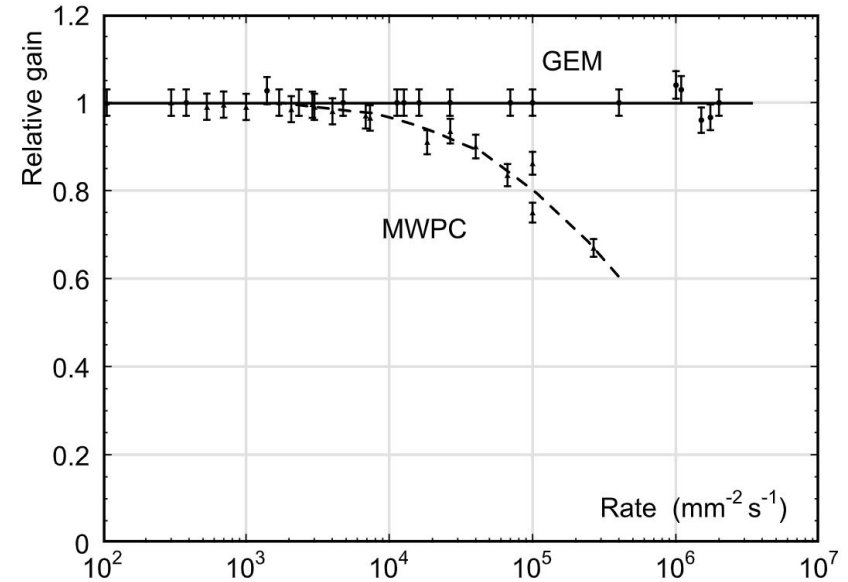

PDG. Review of Particle Physics, vol. 083C01, 2020

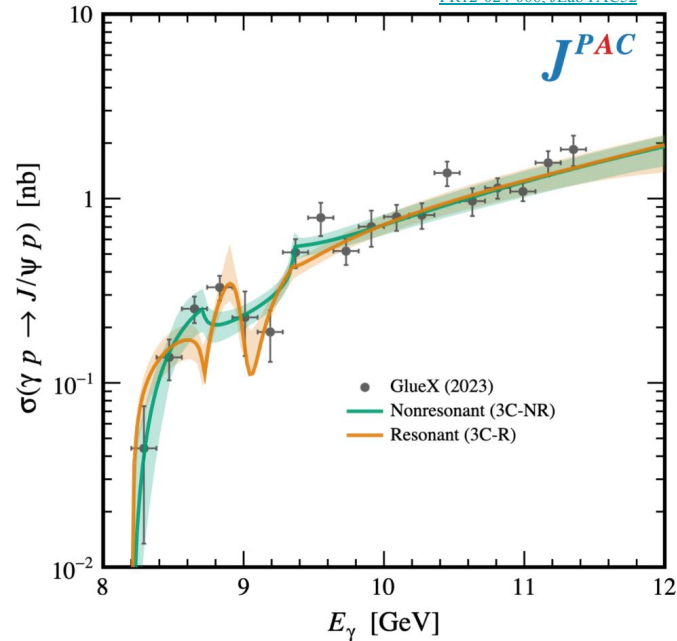
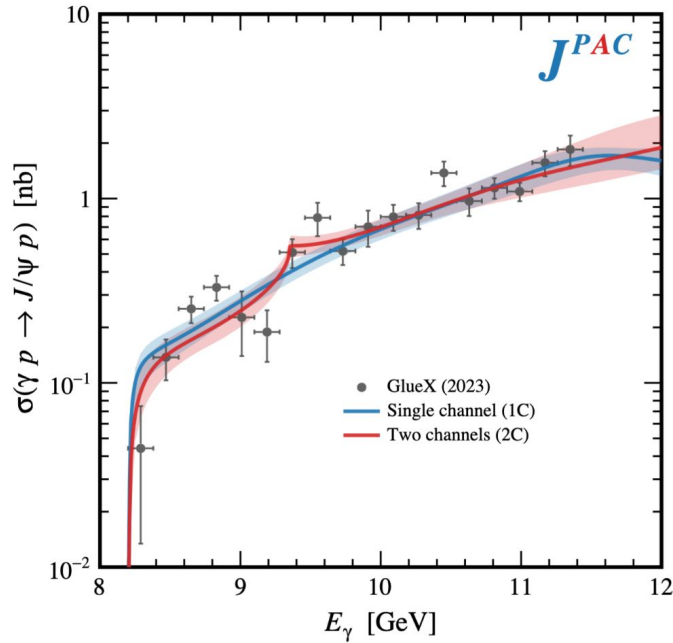

Phenomenological model based on s-channel PW expansion ($l \leq 3$):

- (1C) $J/\psi p$ interaction
- (2C) $J/\psi p$ and $\bar{D}^* \Lambda_C$

- (3C-NR) $J/\psi p, \bar{D} \Lambda_C, \bar{D}^* \Lambda_C$ (non-resonant solution)
- (3C-R) $J/\psi p, \bar{D} \Lambda_C, \bar{D}^* \Lambda_C$ (resonant solution)

Electronics

- GEM detectors typically use APV25 FEE, which are charge-integrating
- For TR application, need charge sampled in time to discriminate dE/dx from TR X-rays. We use flash-ADC for fast sampling / waveform digitization
- Because the FE chain is optimized for fast sampling, higher effective gain ($>10^4$) required for adequate signal-to-noise ratio

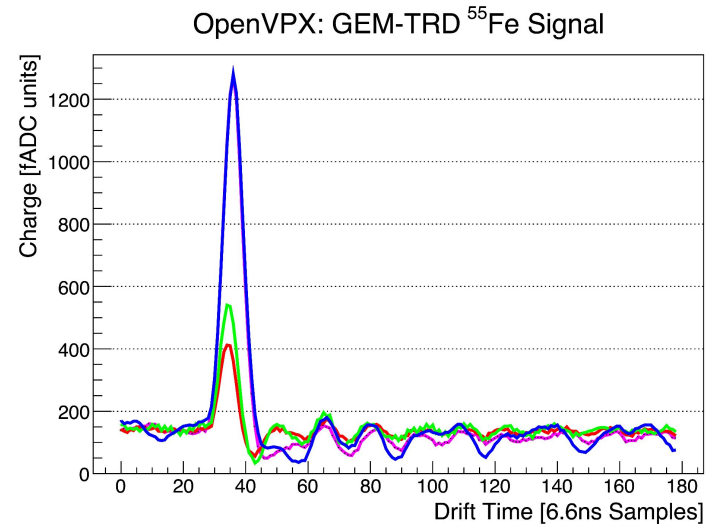
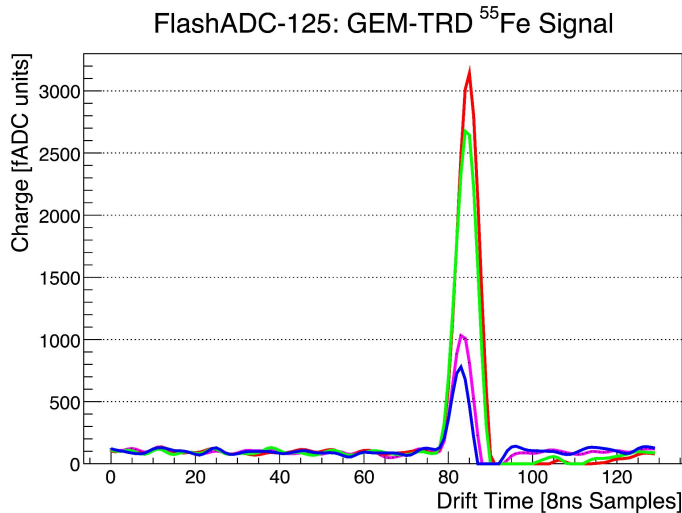

Readout Foil Design at CERN

- Designed by Bertrand Mehl (MPGD group at CERN)

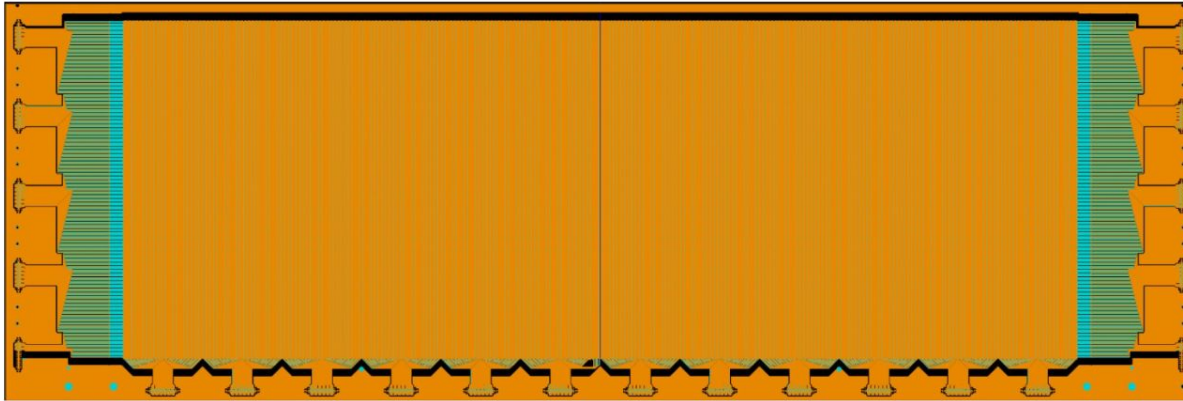

- Readout structure is the same as RO for prototype
 - X pad-like strip: pad size = $450\mu\text{m} \times 900\mu\text{m}$
 - Y large strip: $w = 350\mu\text{m}$
- Dimensions are matched with detector designs from UVa & JLab

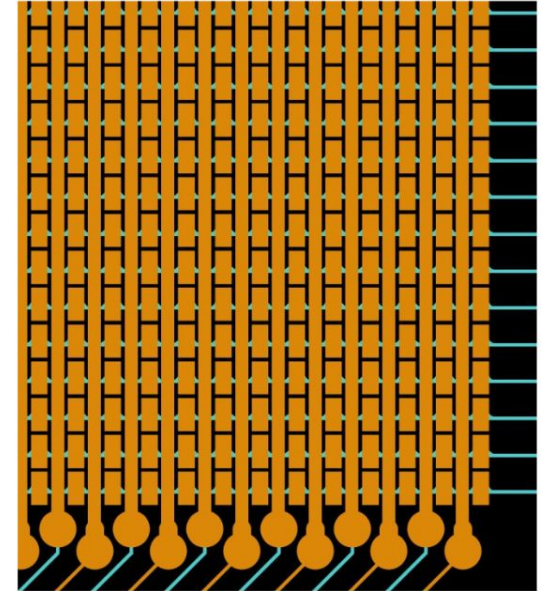
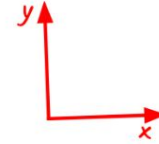

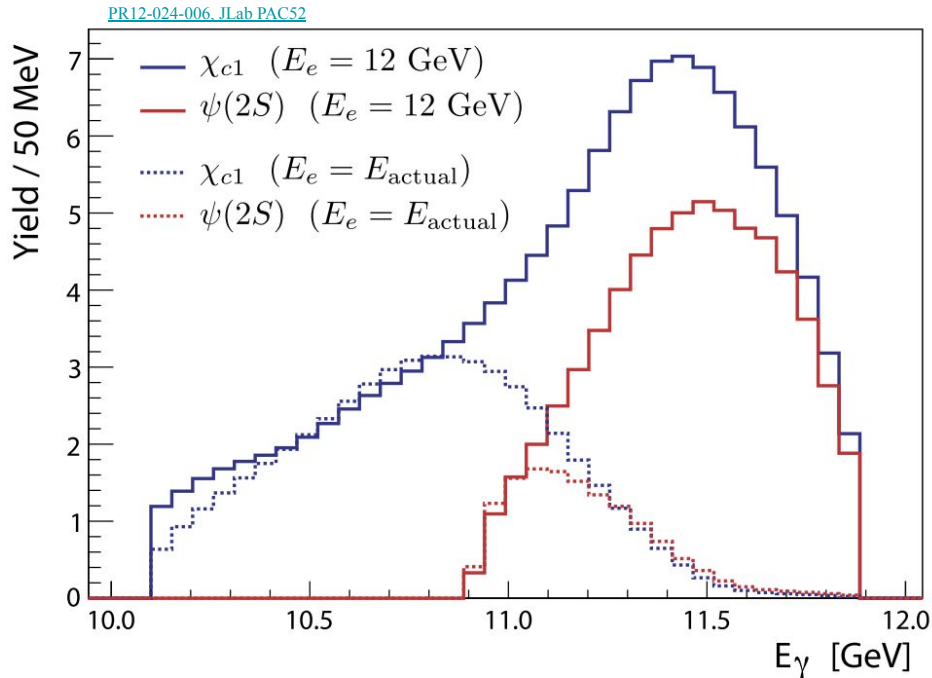

Yield vs. beam energy for χ_{c1} (blue) and $\psi(2S)$ (red) events. Dotted lines = approximate yield vs. energy for currently analyzed GlueX-I and partial GlueX-II data; solid lines = projection for the yield vs. beam energy under assumption of all currently analyzed data collected with $E_{\text{beam}} = 12$ GeV

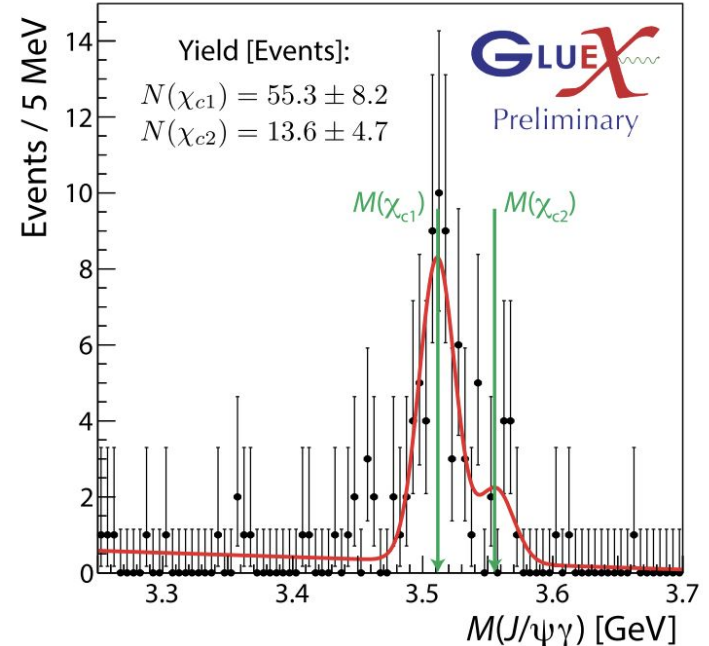

$M(J/\psi\gamma)$ mass spectrum for the GlueX-I and partial GlueX-II data; the integral of the dotted blue curve on the left matches the χ_{c1} yield here

Yellow Report ePIC e/π Capability

Dual-Ring Imaging Cherenkov Detector (dRICH)

- Total PID system must separate e 's from charged particles with $> 3\sigma$ $\pi/K/p$ separation in all rapidity regions

radiator	index	Threshold (GeV/c)			
		e	π	K	p
quartz (DIRC)	1.473	0.00048	0.13	0.47	0.88
aerogel (mRICH)	1.03	0.00207	0.57	2.00	3.80
aerogel (dRICH)	1.02	0.00245	0.69	2.46	4.67
C ₂ F ₆ (dRICH)	1.0008	0.01277	3.49	12.34	23.45
CF ₄ (gRICH)	1.00056	0.01527	4.17	14.75	28.03

Table 11.40: Table of Cherenkov thresholds for various media.

forward region Technology	Range (GeV/c)	
	e - π	π - K
CsI RICH	0.0150 - 20	14.75 - 50
dRICH (aerogel)	0.0025 - 5	2.46 - 16
dRICH (gas)	0.0127 - 18	12.34 - 60
dRICH (overall)	0.0025 - 18	2.46 - 60
TOF (LGAD)	0 - 1	0.00 - 5
TOF (LAPPD 4m 5ps)	0 - 2.5	0.00 - 16
TRD	1.0 - 270.0	-

Table 11.41: Performance ranges for possible forward region detector technologies.

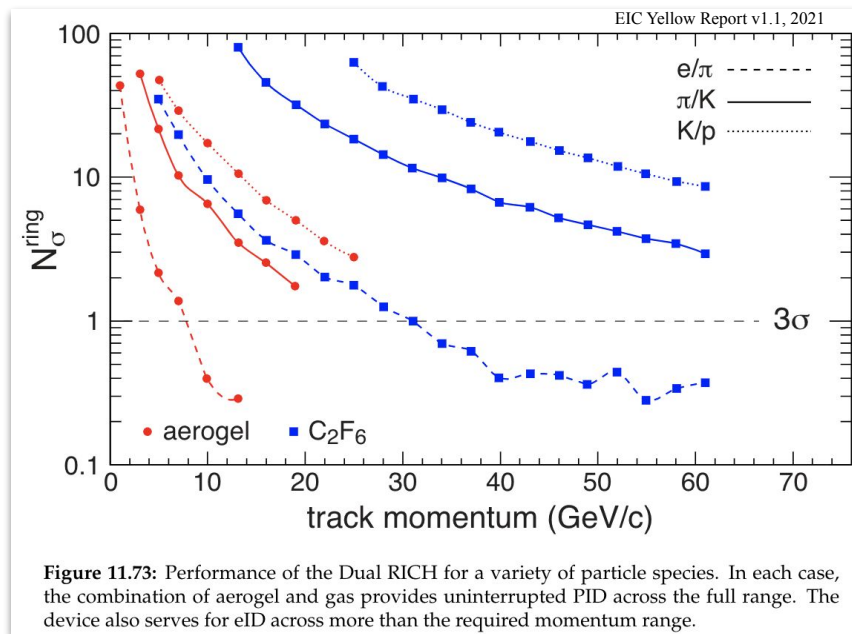

Figure 11.73: Performance of the Dual RICH for a variety of particle species. In each case, the combination of aerogel and gas provides uninterrupted PID across the full range. The device also serves for eID across more than the required momentum range.

“... it is likely wise to supplement the dRICH tracking with a detector that provides an additional space point beyond the radiation volume.” - EIC Yellow Report v1.1 2021, pg 532

GEM-TRD Relevance to EIC

- EIC physics needs precise PID: $>3\sigma$ separation of e 's from charged hadrons across all rapidity regions. Particularly challenging in hadron-going direction; high particle rate boosted in lab frame means rigorous e ID ≥ 15 GeV/c
- Important for J/ψ reconstruction, and even more so for Y where cross section will be low

arXiv:2108.02871 [hep-ph]

Vector-Meson	m_V (MeV)	$\sqrt{s_{thr}}$ (MeV)	E_{thr} (MeV)	k_{thr} (MeV/c)
$\omega(782)$	782.65	1720.9	1109.1	604.7
$\phi(1020)$	1019.461	1957.7	1573.3	754.0
$J/\psi(1S)$	3096.900	4035.2	8207.8	1908.5
$\Upsilon(1S)$	9460.30	10398.6	57152.9	5156.9

$\gamma p \rightarrow V p$

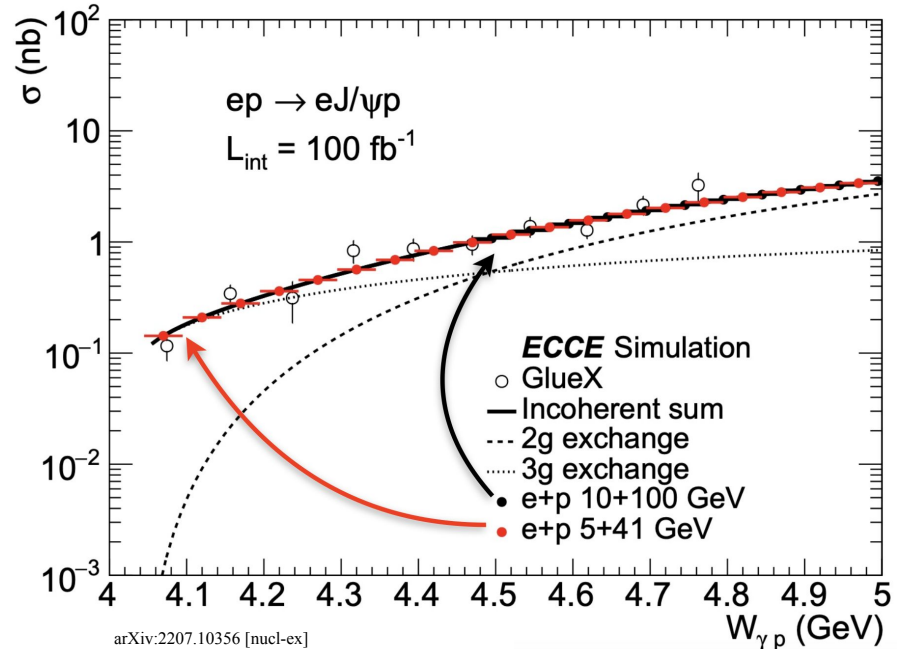
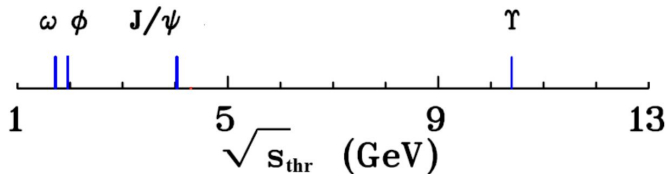

arXiv:2207.10356 [nucl-ex]

J/ψ production close to threshold at EIC

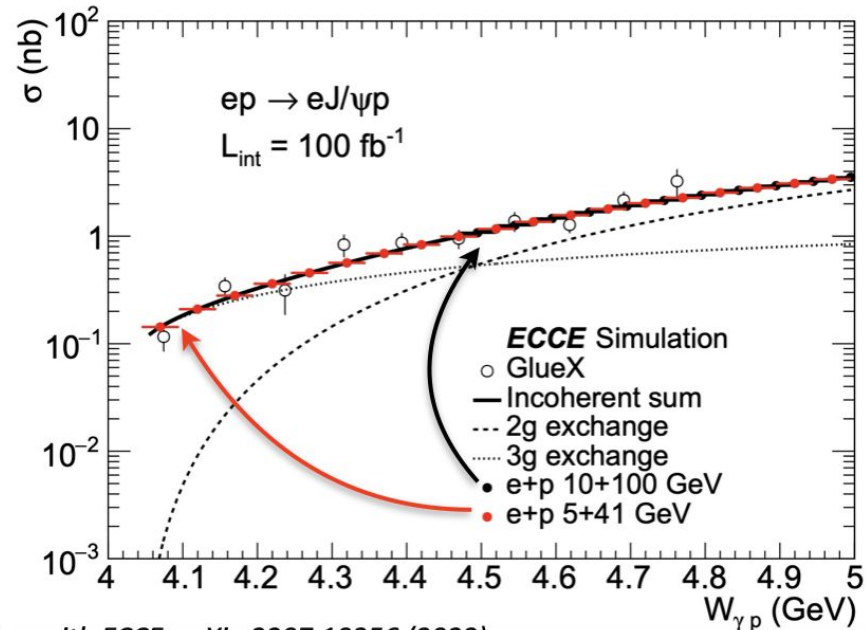

[L. Pentchev, 2024 Science at the Luminosity Frontier: Jefferson Lab at 22 GeV](#)

Exclusive J/ψ detection with ECCE: [arXiv:2207.10356 \(2022\)](#)

- 5+41 GeV beam configuration needed to reach threshold, however it has **very low luminosity (4.4 fb^{-1} annually)**
- Difficult to detect scattered electron with energy close to electron beam energy - **bad $W_{\gamma p}$ resolution**
- Using the detected J/ψ and proton to calculate $W_{\gamma p}$ also leads to a bad resolution (*Sylvester Joosten*)

JLab PAC Proposals Related to GEM-TRD Upgrade

PR12-24-006 [PR12-24-006, JLab PAC52](#)

Scientific Rating: A

Recommendation: Approved for 200 PAC days in Hall D

Title: GlueX-III: a path to the Luminosity Frontier in Hall D

Spokespersons: M. R. Shepherd

Motivation: This proposal seeks to continue data-taking using the GlueX spectrometer in Hall D, taking advantage of higher beam current and possibly higher beam energy (up to 12 GeV) to collect an important sample of charmonium photoproduction events. The relatively large-statistics data, including photon polarization, that will be collected by this experiment will allow examination of the photoproduction mechanism for J/ψ , which is currently not established. In addition, GlueX will continue to use data collected with a relatively open trigger to examine the light hadron spectrum, collecting sufficient statistics to be able to carry out partial-wave analysis on some currently statistics-limited light meson final states.

Measurement and Feasibility: There are no technical concerns that the GlueX collaboration will continue their successful data taking. The addition of a TRD will provide additional important capabilities in the electron-pion separation, which suppresses combinatorial backgrounds and make the data samples cleaner for a partial wave analysis. The PAC considers the program to understand the J/ψ production mechanism critical for the community that aims to use J/ψ for studying nuclear structure.

C12-23-009 [C12-23-009, JLab PAC52](#)

Scientific Rating: N/A

Recommendation: Deferred

Title: Nuclear Charm Production and Short-Range Correlations

Spokespersons: O. Hen (contact), J. Pybus

Motivation: The proposed experiment aims to measure the $|t|$ -dependence of the 2N-SRC process in ${}^4\text{He}(\gamma, \rho^0 \text{pp})$ and ${}^4\text{He}(\gamma, \rho^+ \text{pp})$, to search for exclusive 3N-SRC breakup with ${}^4\text{He}(\gamma, \rho^0 \text{ppp})$ and ${}^4\text{He}(\gamma, \rho^+ \text{ppp})$, and to measure semi-inclusive J/ψ production on ${}^4\text{He}$ (γ ${}^4\text{He} \rightarrow J/\psi \text{ p X}$) as a function of E_γ , $|t|$, and a light-cone variable α_{miss} in and above the subthreshold regime.

PR12-25-002 [PR12-25-002, JLab PAC53](#)

Scientific Rating: B+

Recommendation: Approved for 85 PAC days in Hall D

Title: Threshold J/ψ Photoproduction as a Probe of Nuclear Gluon Structure

Spokespersons: D. Dutta, H. Gao, O. Hen (contact), T. Kolar, I. Korover, J. R. Pybus, A. Schmidt, A. Somov, H. Szumila-Vance

Motivation: There have been many observations of nuclear medium modification in quarks, but the behavior of gluons in nuclei remains almost completely unknown. The recent publication of the first measurements of sub- and near-threshold J/ψ production from deuterium, helium, and carbon nuclei using the GlueX detector has placed some constraints on the models of gluon distribution modifications in bound nucleons. However, the available data are still very limited and do not allow for a conclusive observation or exclusion of large modifications in gluon distributions. A precision experiment of a similar type could make such a determination possible.

LOI12-24-001 [LOI12-24-001, JLab PAC52](#)

Title: Hadron spectroscopy with a polarized target at GlueX in Hall D - From the strange to the charm sector

Spokespersons: F. Afzal (contact), M. M. Dalton, P. Hurck, A. Thiel, Y. Wunderlich, K. Livingston

Motivation: The main research goal of this LOI is to provide new insights towards understanding QCD confinement, testing quark model and lattice QCD predictions. To this end, it is proposed to perform a measurement with an elliptically (both circularly and linearly) polarized photon beam and a longitudinally polarized target at GlueX in Hall D. Thus, one will be able to measure a large set of polarization observables and can expect to make a significant contribution towards accomplishing a complete experiment and towards mapping out the hyperon spectra. The measurement will provide much needed data, which will be complementary to the data planned to be taken with the K_{Long} Facility in Hall D (C12-19-001). The second part of the LOI describes the use of double polarization observables to search for potential pentaquark resonances and open-charm threshold contributions in J/ψ photoproduction.

Projected Impact on GlueX-III Physics Program

- BH yields are estimated in bins of $M(e^+e^-)$ from BCAL and FCAL p/E ratios
- Scaling down the pion background by factor 6 and re-extracting BH yields:

Example of projected performance using GlueX-I data for $1.73 \text{ GeV} < M(e^+e^-) < 2 \text{ GeV}$

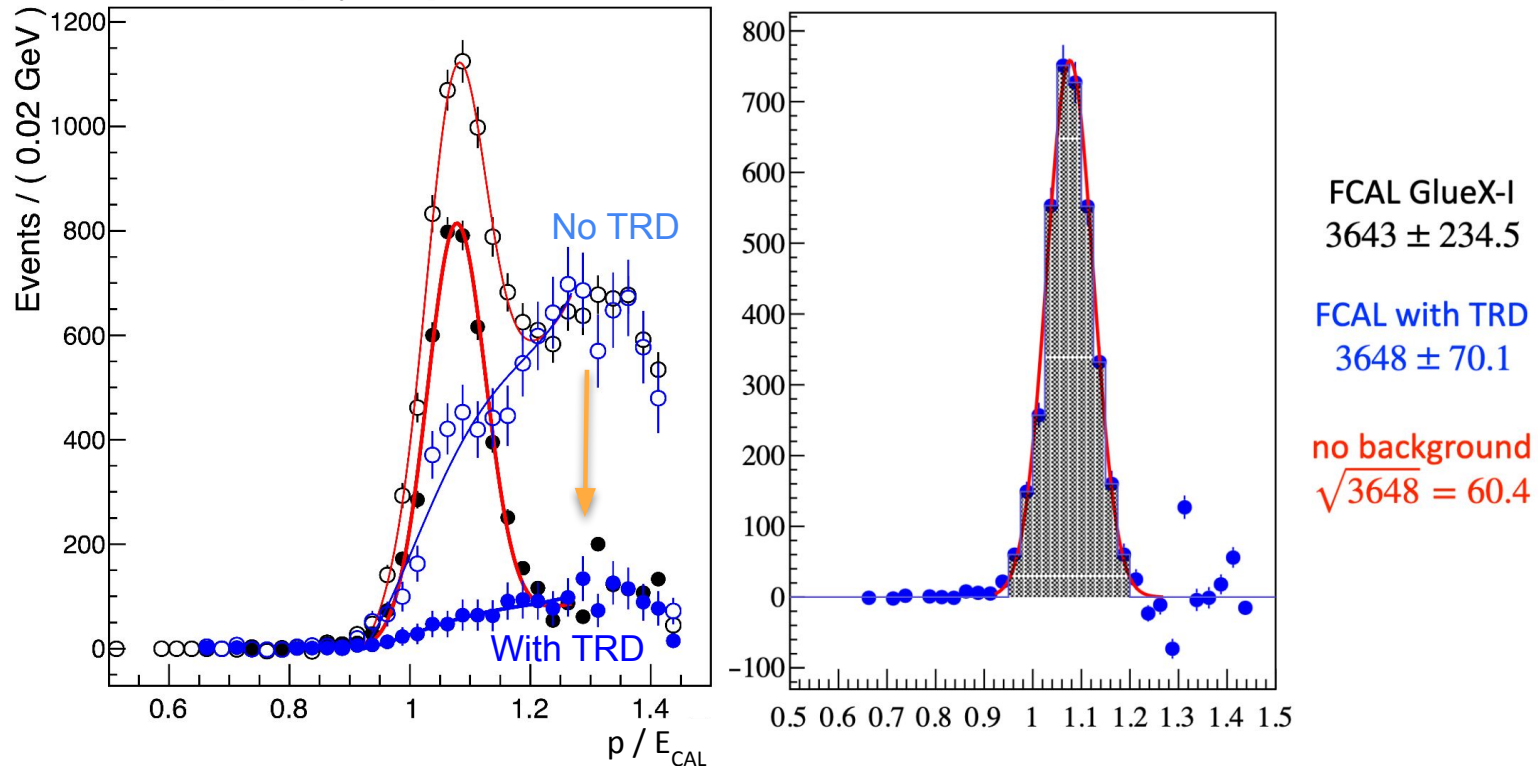

- Detector readout integrated into GlueX DAQ
- TRD Point (3D) objects correlated with GlueX track projections and FCAL shower info

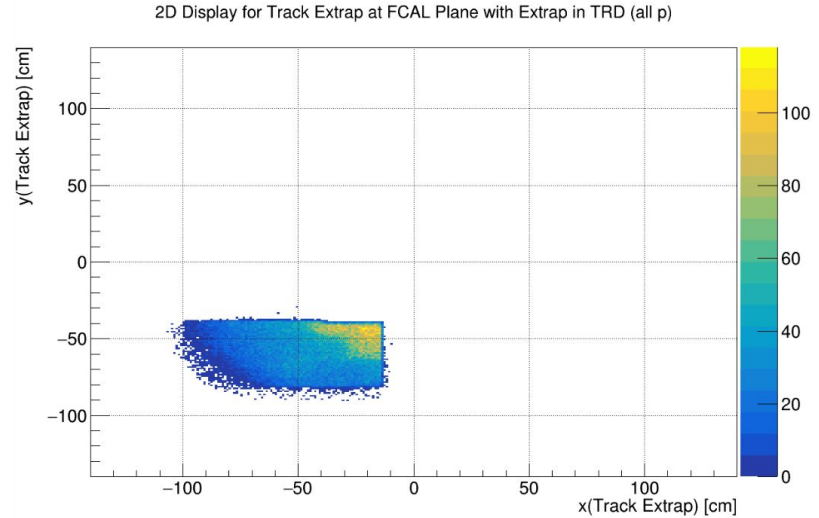
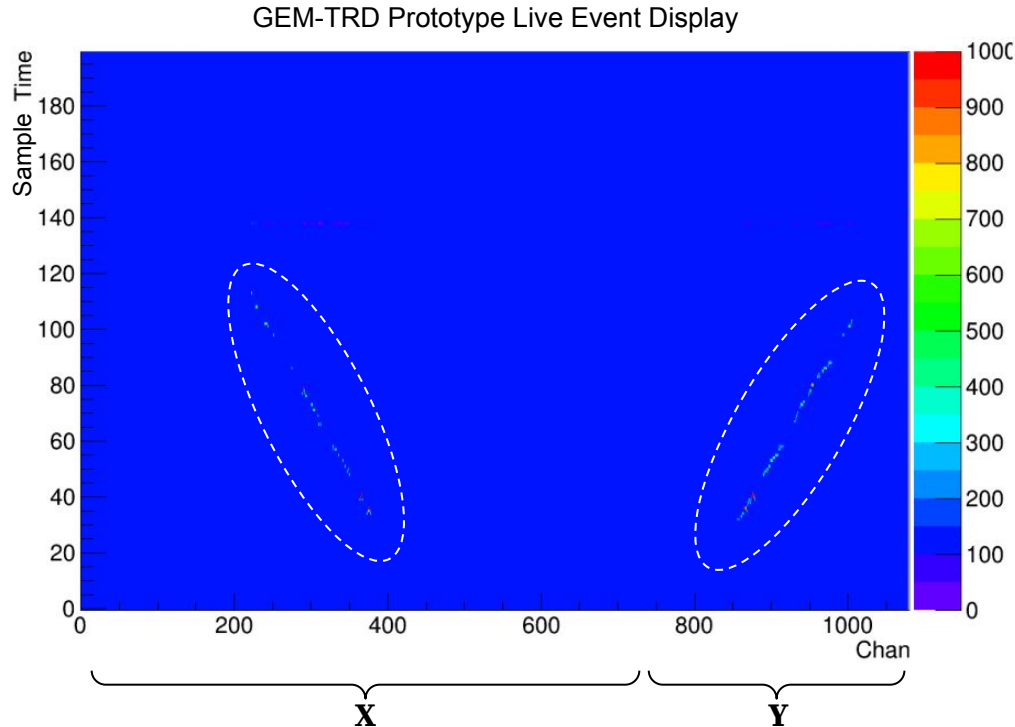

GEM-TRD Prototype Track Matching

- Collected data for developing integration into GlueX software, like track-matching validation
- Look at charged tracks extrapolated through TRD prototype acceptance region, check for ionization deposit constructed in XYZ of detector drift gap

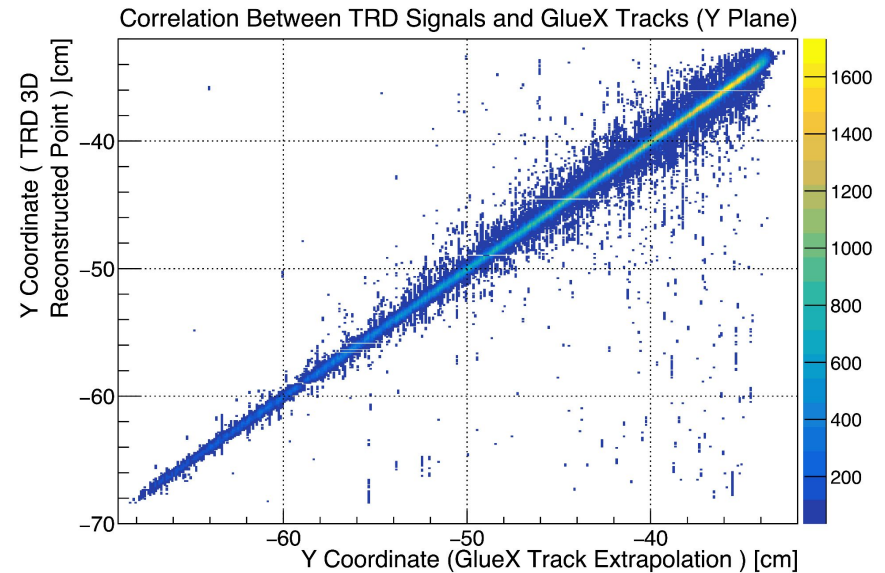
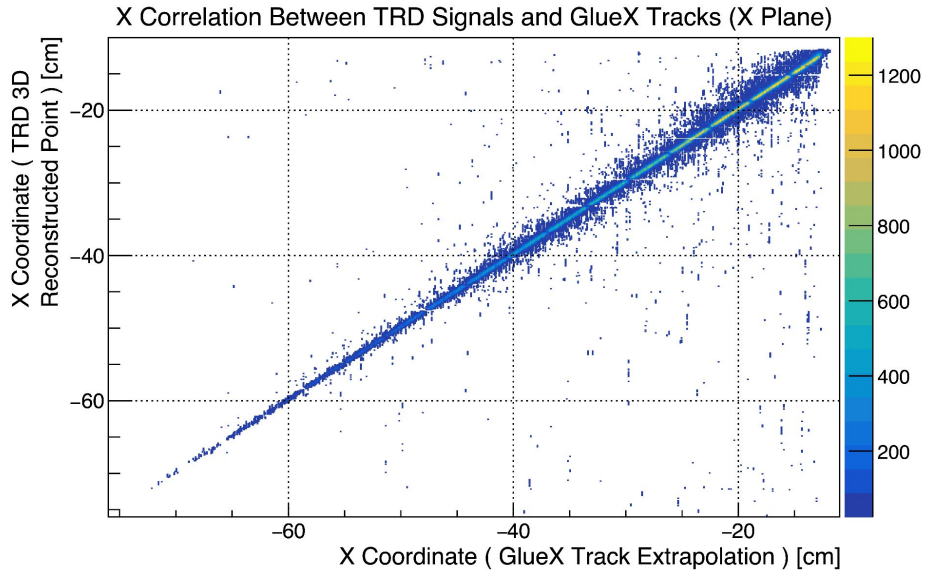

3D Charged Track Reconstruction in Small Prototype

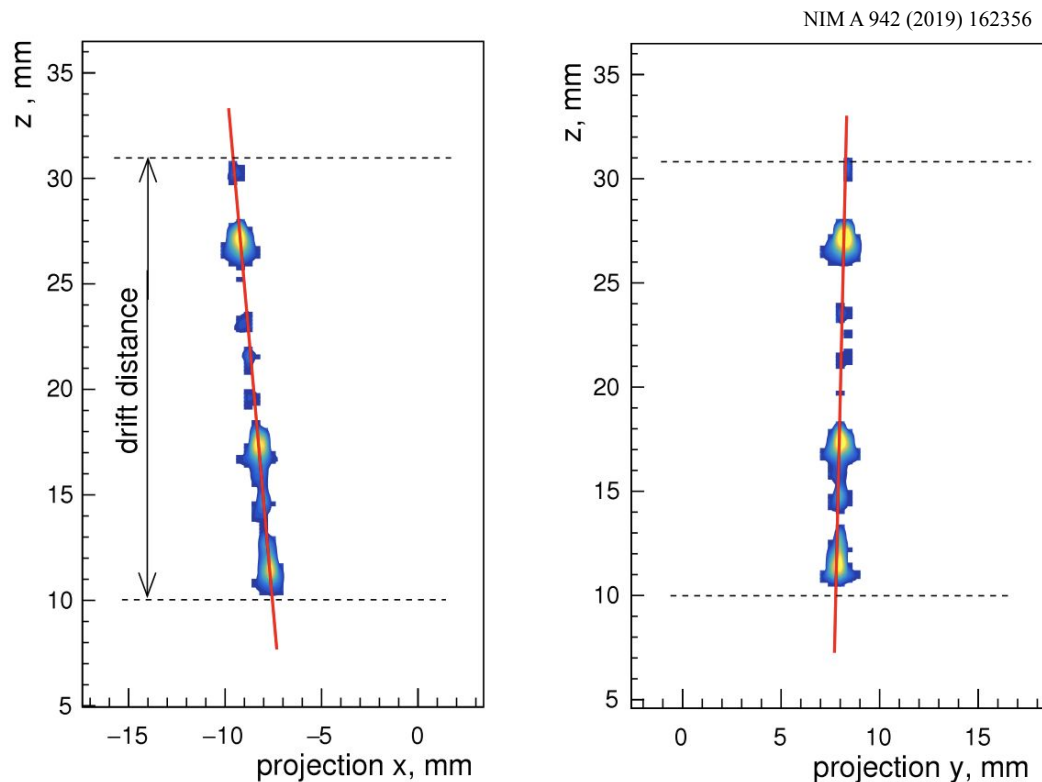
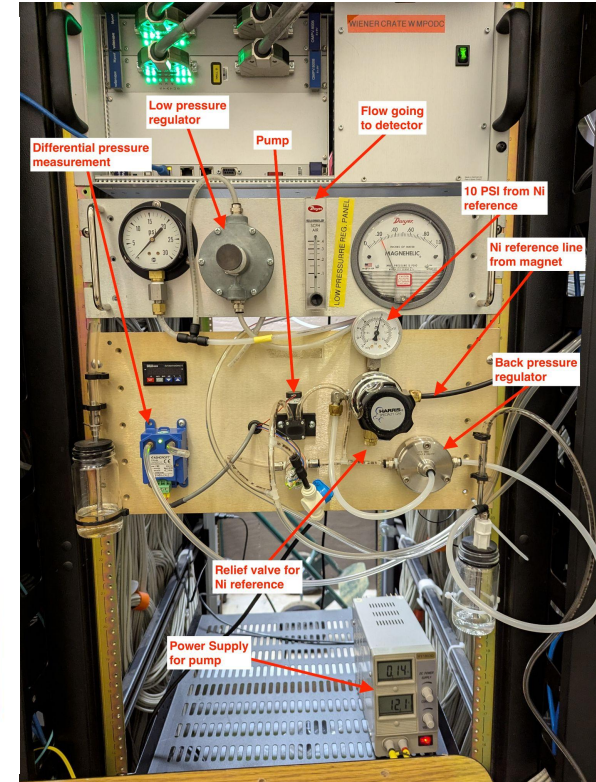
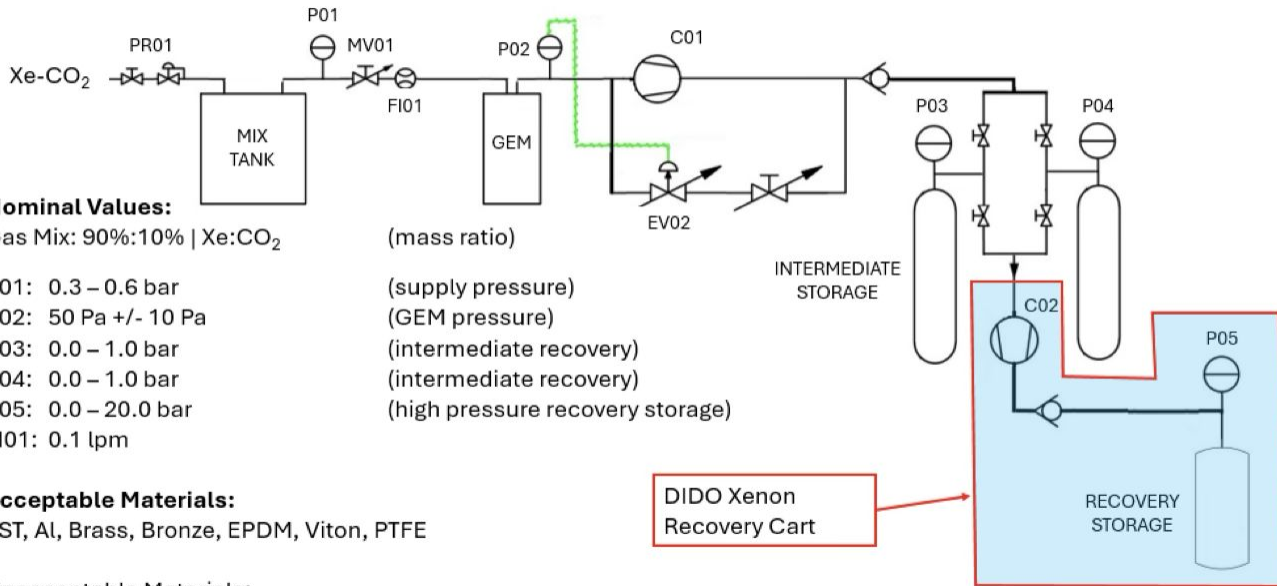

Fig. 12. Single track reconstruction.

Gas Regulation System

- Pump pulls gas through detector, +/-2pascal regulation inside chamber
- TRDs require heavy gas for efficient X-Ray absorption (\$\$\$)

GEM TRD Preliminary Gas System Specifications



Gas Regulation System

- Portion of the full system to be developed, first time connecting system to a detector
- Multiple benefits realized
 - Conservation of heavy gas
 - Allow fine control of internal pressure (ind. of flow)
 - Reduce window bulging → more uniform E_Field
 - Reduced drift gap size (less HV needed for adequate drift field)
 - Gas analyzer connection on detector output (gas quality monitoring)

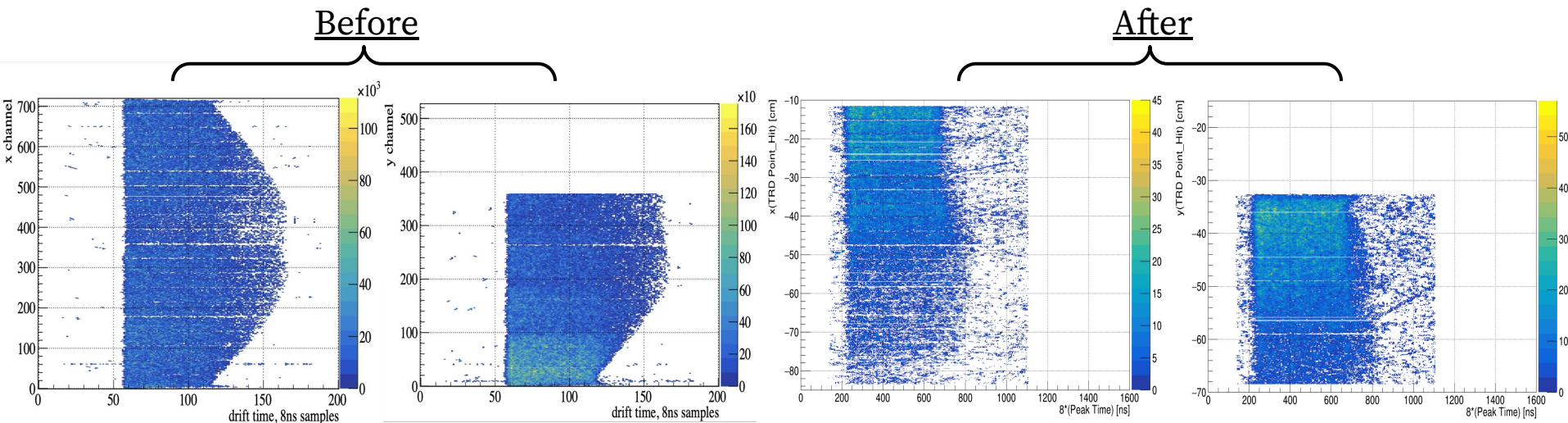

Structure of Cathode Foil for GlueX GEM-TRD

H. Nguyen, GEM-TRD Design & Production Plan

Optimizing Cathode Thickness

- Studies done by Lauren Kasper

Thickness of Aluminum layer:

- ➔ Transparency of soft transition radiation (3 -40 keV)
- ➔ Robust mechanical integrity
- ➔ Current chosen thickness:

1.5 μm

Thickness of Kapton layer

- ➔ Kapton layer has negligible effect on the X-ray spectrum
- ➔ Current chosen thickness:

50 μm

Ratios of Spectra Absorbed in Detector Sens. Area

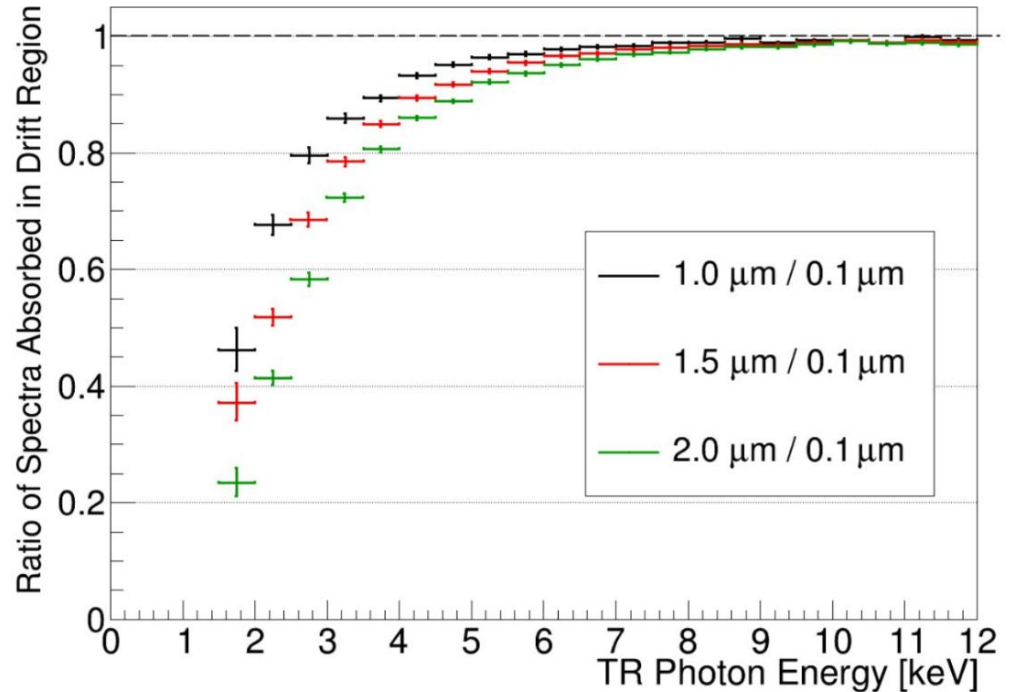

Aluminum Thickness Studies

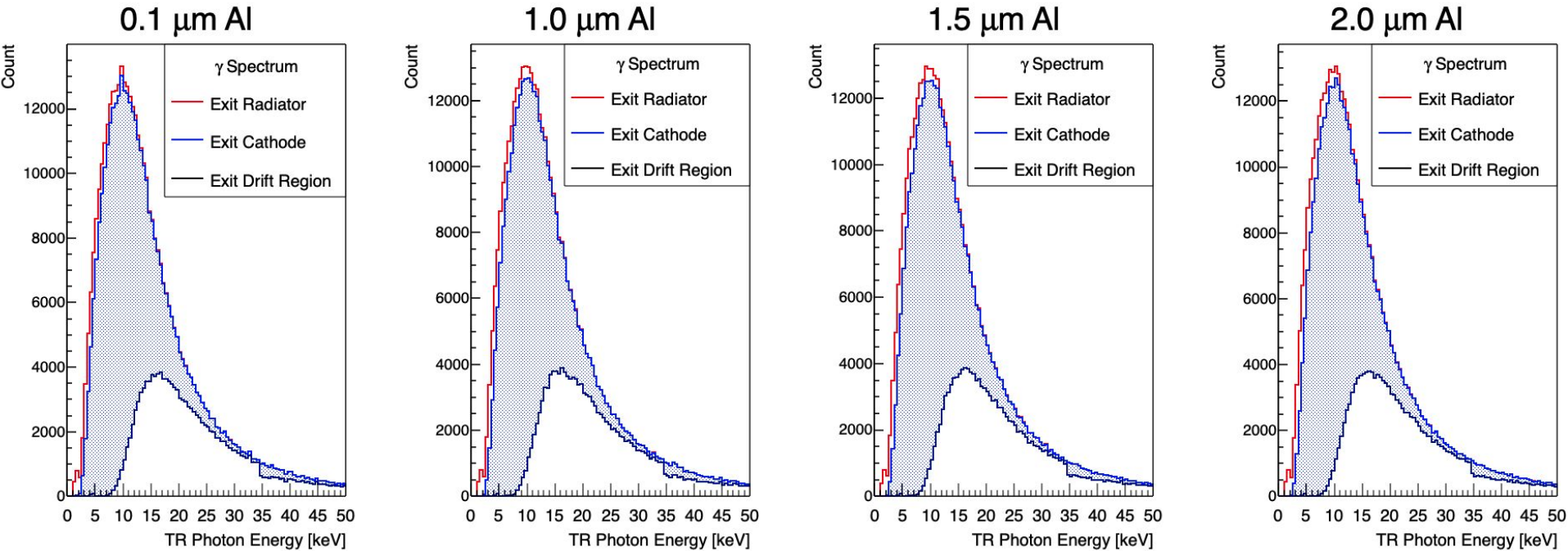

Increased thickness degrades the soft TR photon yield that enters the detector, but minimum thickness must not compromise mechanical/electrical integrity

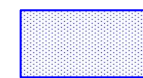

Shaded region represents spectra absorbed in detector sens. area

Cathode Material Studies

0.1 μm Gold

0.5 μm Copper

1.0 μm Aluminum

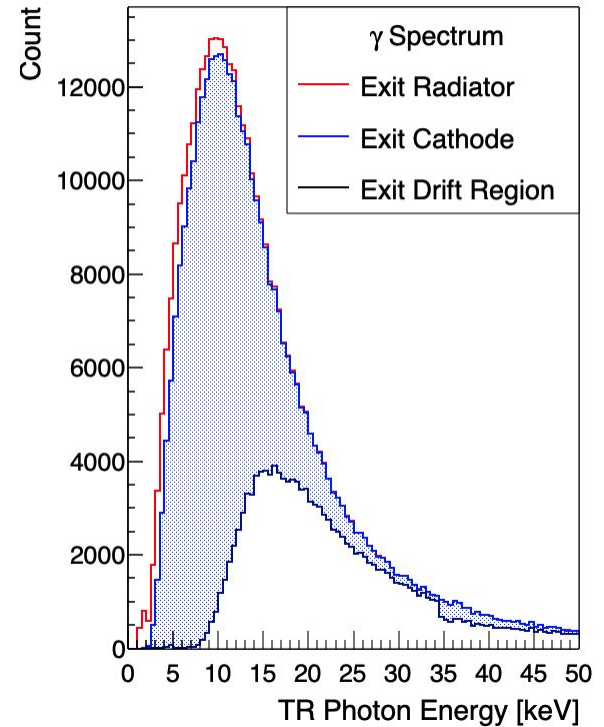
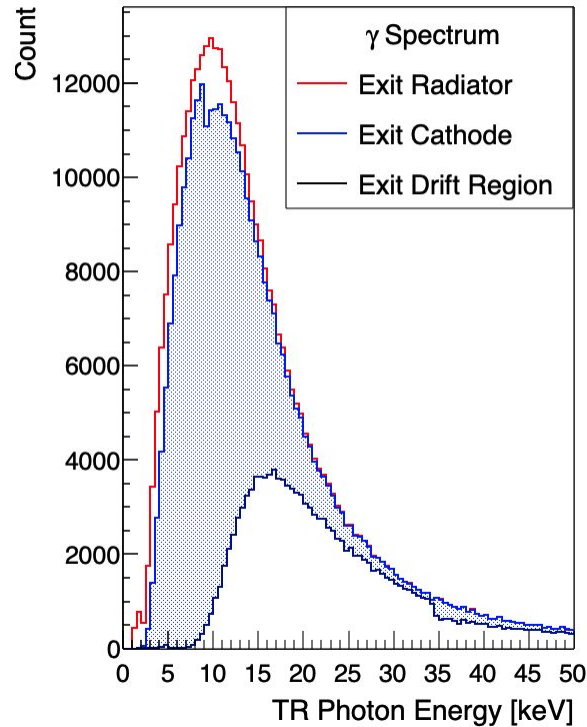
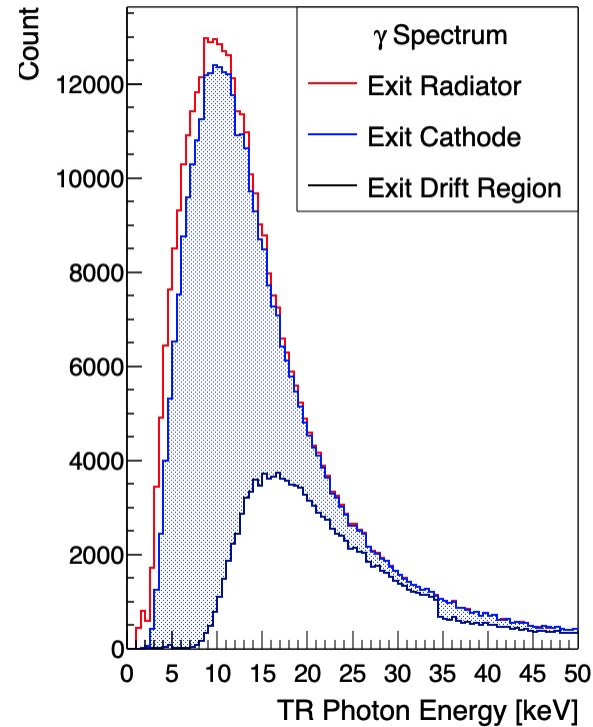

Aluminum provides more transparency to soft TR photons, even when thicker than other materials

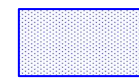

Shaded region represents spectra absorbed in detector sens. area

Structure of Cathode Foil for GlueX GEM-TRD

Optimizing Cathode Thickness

Studies done by Lauren Kasper

Thickness of Aluminum layer:

- ➔ Transparency of soft transition radiation (3 -40 keV)
- ➔ Robust mechanical integrity
- ➔ Current chosen thickness:
1.5 μm

Thickness of Kapton layer

- ➔ Kapton layer has negligible effect on the X-ray spectrum
- ➔ Current chosen thickness:
50 μm

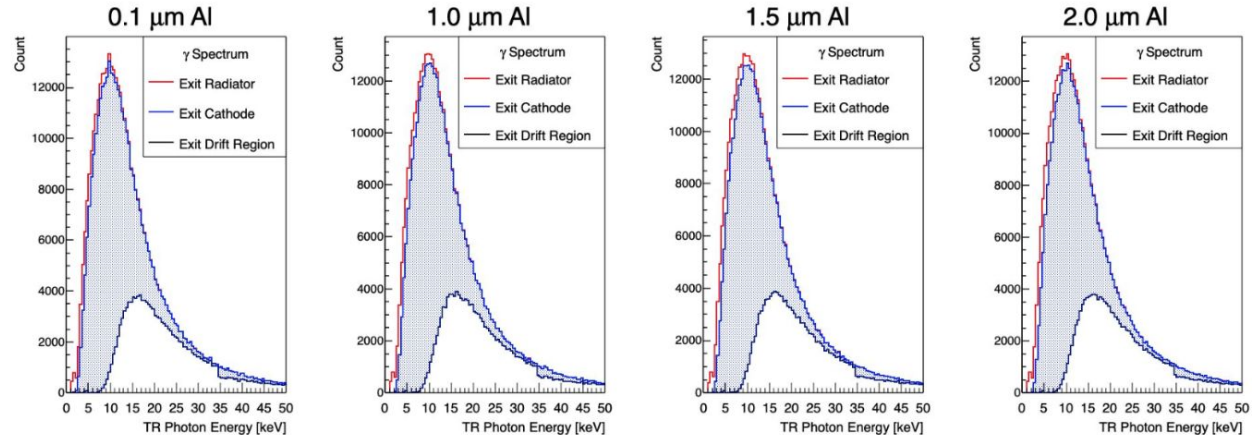

Shaded region represents spectra absorbed in detector sens. area

Increased thickness degrades the soft TR photon yield that enters the detector, but minimum thickness must not compromise mechanical/electrical integrity

TRD Gas Mixtures

- Compare various noble gases in terms of absorption power for 20 mm gas thickness. Best gas is Xe
- Xe-based mixture requires higher fields (~ 2000 V/cm) for a similar drift velocity as Ar (~ 1000 V/cm). High cost of Xe means closed loop gas system is necessary

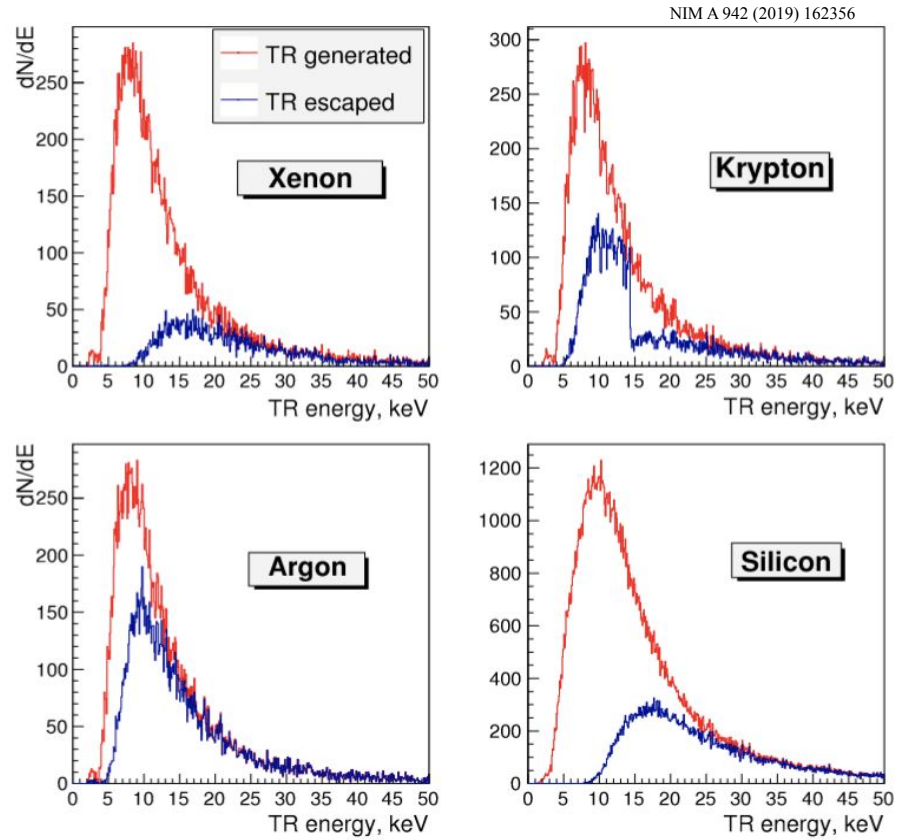
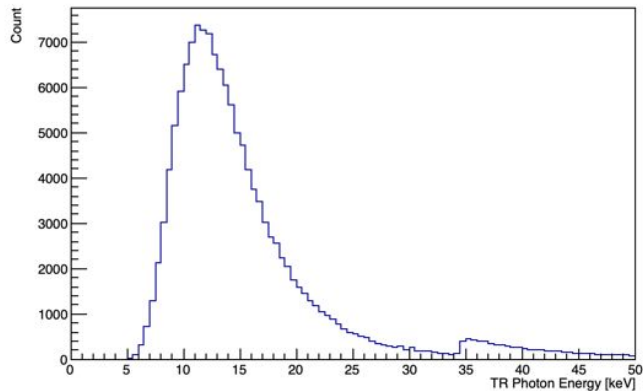

Fig. 3. TR absorption efficiency for different gas mixtures and silicon.

Xe:CO₂ 90:10 vs Kr:CO₂ 90:10

50um Kapton, 0.1um Al, 30mm XeCO₂



50um Kapton, 0.1um Al, 30mm KrCO₂

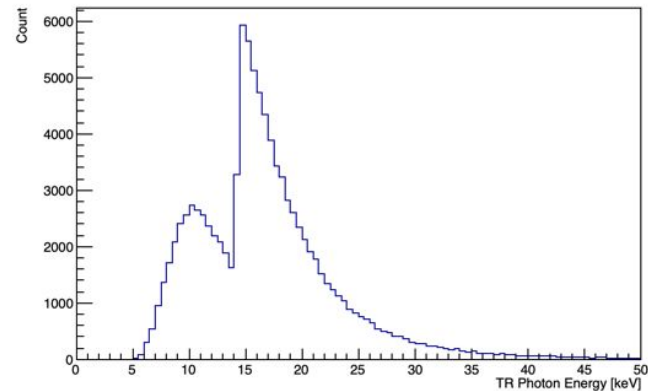

50um Kapton, 0.1um Al, 30mm XeCO₂

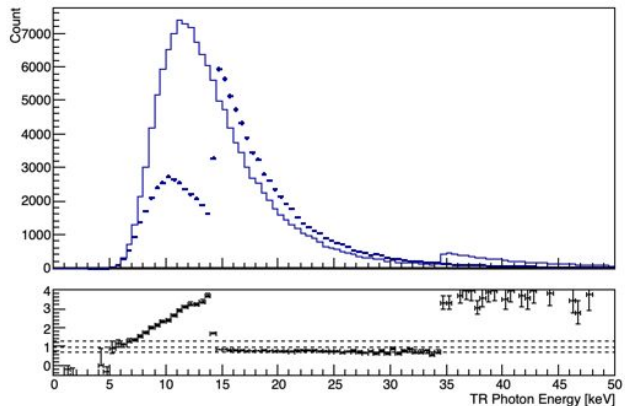

Cyclic Efficiency Behavior

Tests in real experimental environment revealed this issue, potentially saving us much headache in designing/commissioning full detector for GlueX-III

Problem appears to depend on: HV, gain, intensity... But nature of the problem is still unclear. Not seen in previous tests (in PS electron dump)

~200nF capacitance in GEM foil, 10M Ω resistance in divider, roughly gives this time constant

200nA AMO rad, 7000V/3600V, KrCO₂ 90:10

GEMTRD Plane Hit-Level Extrapolation Efficiency Estimate Vs Time

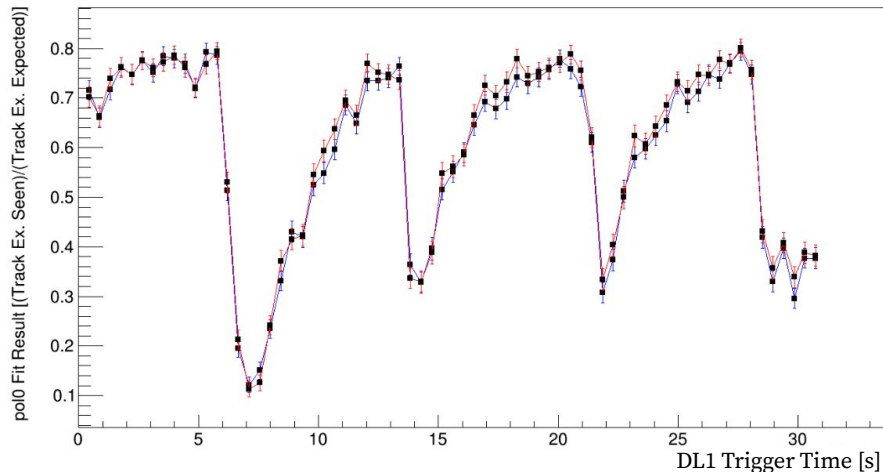

200nA AMO rad, 7000V/3700V, KrCO₂ 90:10

GEMTRD Plane Hit-Level Extrapolation Efficiency Estimate Vs Time

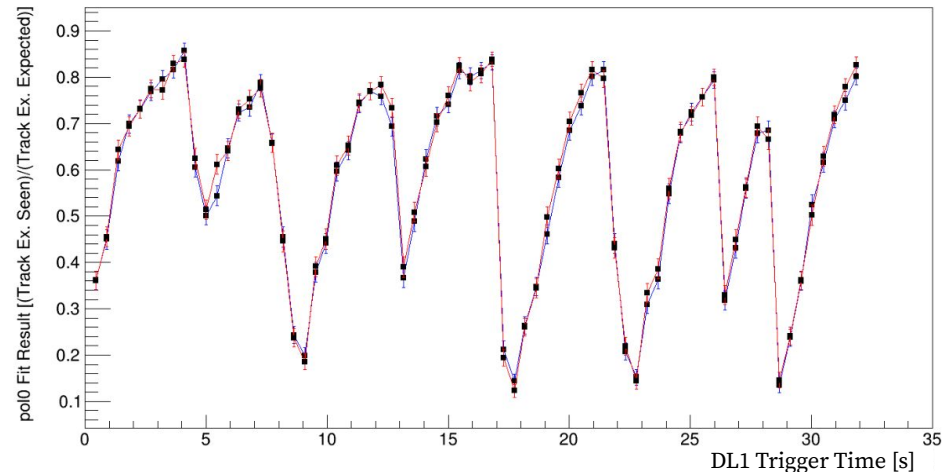

Cyclic Behavior

